

REQUEST FOR PROPOSAL

RFP No. C-1752



TERMINAL FACILITIES BUILDING TALLEYRAND MARINE TERMINAL

THIS PROJECT WILL BE CONSTRUCTED UTILIZING
THE DESIGN-BUILD DELIVERY METHOD

RFP DUE DATE: WEDNESDAY, SEPTEMBER 22, 2021

Sandra Platt, Sr. Contract Specialist

sandra.platt@jaxport.com

PROCUREMENT SERVICES

2831 Talleyrand Avenue, Jacksonville, Florida 32206

JAXPORT.com/procurement/active-solicitations

REQUEST FOR PROPOSAL
DESIGN-BUILD TERMINAL FACILITIES BUILDING
TALLEYRAND MARINE TERMINAL
CONTRACT NO. C-1752

PUBLIC NOTICE

The Jacksonville Port Authority is soliciting Requests for Proposals (RFPs) for a Design-Build firm to design, permit, furnish, and construct a pre-engineered metal building at JAXPORT's Talleyrand Marine Terminal. The work includes, but is not necessarily limited to, footings/foundations, steel framing/structure, metal roofing, metal siding (walls), power, lighting, grounding, roof vent system, lightning protection system (if required by Code), reinforced concrete floor, gutters and downspouts.

Submission of an RFP Package (Qualifications, Technical and Price Proposals) does not guarantee that any responding firm will receive a contract from JAXPORT, nor does it imply that your firm has any type of procurement or contractual relationship with JAXPORT either now or in the future. Information provided by your firm will be treated in a reasonable manner and will be subject to disclosure pursuant to the laws of the State of Florida. Concurrent with this policy, JAXPORT conducts its procurement activities and formal bid processes in a competitive environment that fosters equal opportunity for qualified companies to provide services that meet our requirements.

SUBMISSION OF QUALIFICATIONS AND TECHNICAL PROPOSALS
WEDNESDAY, SEPTEMBER 22, 2021 AT 2:00 PM (EST)

SUBMISSION OF PRICE PROPOSALS

Note: ONLY competitive range qualified proposers will be invited, under a separate invitation key, to submit a price proposal
FRIDAY, OCTOBER 1, 2021 AT 2:00 PM (EST)

MANDATORY PRE-PROPOSAL MEETING
TUESDAY, SEPTEMBER 7, 2021 AT 10:00 AM (EST)

PROPOSAL CONTENTS AND FORMAT

Interested proposers shall prepare and electronically submit, RFP packages consisting of proposer REQUIREMENTS as listed below, and any other information required in order to be considered for award of this project. JAXPORT no longer accepts any bid packages submitted by Mail or Hand Deliveries. Please visit the JAXPORT's website at www.jaxport.com for more information and updates. RFP packages received via email, fax, or hand delivery will be declared nonconforming and will not be read or accepted.

1. The RFP package (**SOQ & Technical Proposal**) shall contain all information pertaining to the **Proposer's Qualifications and Technical Proposal**. This PDF file shall read as follows:
“C-1752 Terminal Facilities Building – SOQ and Tech Proposal”

The electronically submitted documents shall contain the following information:

- a. Acknowledgement of all addenda, Signature Page
- b. Exhibit “A” - Conflict of Interest, COI Form
- c. Exhibit “B” - Sworn Statement/Section 287.133(3)(a), Florida Statutes - Public Entity Crime, PEC Form
- d. Exhibit “C” - E-Verify Program for Employment Verification, E-Verify Form
- e. Exhibit “D” - Contractor Certification Regarding Scrutinized Companies, Form CCRSC.
- f. Bidders Representation and Authorization – Written Statement (Only if necessary).

2. The RFP package (**Price Proposal**) shall contain the **signed Form PPF-1 through PPF-3, and any other information required** to be submitted by the specifications. This PDF file shall read as follows:

“C-1752 Terminal Facilities Building – Price Proposal”

The electronically submitted documents shall contain the following information:

- a. Bid bond for 5 percent of the amount of the bid (See SECTION II - PRICE PROPOSAL / BONDS).
- b. SEB Form 1, “Schedule of Subcontractor/Sub-consultant Participation”.

The above described packages shall be electronically submitted on two separate dates as follows:

SUBMISSION OF QUALIFICATIONS AND TECHNICAL PROPOSALS

WEDNESDAY, SEPTEMBER 22, 2021 AT 2:00 PM (EST)

SUBMISSION OF PRICE PROPOSALS

Note: ONLY competitive range qualified proposers will be invited, under a separate invitation key, to submit a price proposal

FRIDAY, OCTOBER 1, 2021 AT 2:00 PM (EST)

If your firm does not intend to submit a proposal for this project, please complete “Notice to Prospective Proposers” and fax to (904) 357-3077 or e-mail to Sandra.Platt@JAXPORT.com.



NOTICE TO PROSPECTIVE PROPOSERS

If your firm is not submitting a proposal at this time, please detach this sheet from the Request for Proposal document, complete the information requested, and return to sandra.platt@jaxport.com or fax to 904-357-3077.

NO PROPOSAL SUBMITTED FOR REASON(S) CHECKED AND/OR INDICATED:

- Not responding due to workload issues
- Not responding due to minimum experience requirements
- Not responding due to specifications /scope of services
- Not responding due to timely payment issues
- OTHER (Please specify)
-

We do do not want to be retained on your mailing list for future RFP's for the type or product and/or service.

Signature: _____

Title: _____

Company: _____

<u>TABLE OF CONTENTS</u>		<u>PAGE</u>
SECTION I.	REQUEST FOR PROPOSAL OVERVIEW AND RESPONSE PROCEDURES	7
	A. INTRODUCTION	7
	B. RECEIPT AND OPENING OF PROPOSALS	7
	C. MANDATORY PRE-PROPOSAL AND SITE VISIT MEETING	7
	D. TWO STEP SELECTION PROCESS	8
	E. SUBCONTRACTORS / JOINT VENTURES	13
	F. SMALL & EMERGING PARTICIPATION GOAL	13
	G. RFP SCHEDULE OF EVENTS	14
	H. CONTACT PERSON	14
	I. OMISSIONS, DISCREPANCIES AND ADDENDA	15
SECTION II.	REQUEST FOR PROPOSAL SUBMISSION, FORMAT AND BONDS	16
	A. PROPOSAL SUBMISSION	16
	B. QUALIFICATION PROPOSAL FORMAT	17
	C. TECHNICAL PROPOSAL FORMAT	18
	D. ORAL PRESENTATIONS/INTERVIEWS	18
	E. PRICE PROPOSAL / BONDS	19
SECTION III.	LEGAL TERMS AND CONDITIONS / INSURANCE	21
	A. MODIFICATION/WITHDRAWALS OF SUBMITTALS	21
	B. RFP POSTPONEMENT/CANCELLATION/REJECTION	21
	C. COST INCURRED BY PROPOSERS	21
	D. PUBLIC MEETING REQUIREMENTS	21
	E. PUBLIC RECORDS	21
	F. PROTEST PROCEDURES	23
	G. RULES; REGULATIONS; LICENSING REQUIREMENTS	23
	H. CONFLICT OF INTEREST	23
	I. PUBLIC ENTITY CRIME	23
	J. DISCRIMINATORY VENDOR LIST	24
	K. PROPOSERS REPRESENTATION AND AUTHORIZATION	24
	L. SCRUTINIZED COMPANIES ACTIVITIES IN SUDAN AND/OR IRAN	26
	M. E-VERIFY PROGRAM FOR EMPLOYMENT VERIFICATION	26
	N. RELATION TO JAXPORT	27
	O. CONFORMITY TO APPLICABLE LAWS	27
	P. CONTINGENT FEES PROHIBITED	27
	Q. WAIVER OF IRREGULARITIES	27
	R. INDEMNIFICATION	28
	S. INSURANCE	28
	T. EX-PARTE COMMUNICATIONS PROHIBITED	31
	U. SECURITY IMPLEMENTATION PROCEDURES	32
	V. ELECTRONIC DATA REQUIREMENTS (E-BUILDER)	40
	W. ADDENDA ACKNOWLEDGEMENT / SIGNATURE PAGE	44

EXHIBITS

“A” - CONFLICT OF INTEREST	COI-1
“B” - SWORN STATEMENT/PUBLIC ENTITY CRIMES	PEC-1 TO PEC-2
“C” - E-VERIFY PROGRAM FOR EMPLOYMENT VERIFICATION	E-VERIFY
“D” - CONTRACTOR CERTIFICATION, SCRUTINIZED COMPANIES	CCRSC
“E” - ARTICLE V – JAXPORT PROCUREMENT POLICY FOR JSEB	ARTICLE 5
“F” - E-BUILDER FORM	EB-1

PROPOSAL RELATED FORMS

PRICE PROPOSAL FORM	PPF-1 TO PPF-3
BID BOND FORM	BBF-1 TO BBF-2
SEB FORM 1 - SCHEDULE OF SUBCONTRACTOR/SUBCONSULTANT PARTICIPATION	SEB FORM 1

CONTRACT RELATED DOCUMENTS

GENERAL CONDITIONS	GC-1 TO GC-43
SPECIAL CONDITIONS	SC-1 TO SC-8
REQUIRED LIMITS OF INSURANCE	RLI-1 TO RLI-2
CERTIFICATE OF INSURANCE COMPLIANCE	COIC-1 TO COIC-3
APPLICATION FOR PAYMENT	AFP-1 & AFP-2
REQUEST FOR INFORMATION	RFI
AGREEMENT BETWEEN OWNER AND CONTRACTOR	AGR-1 TO AGR-4
CERTIFICATE OF CONTRACT COMPLETION	FCC
CERTIFICATE OF SUBSTANTIAL COMPLETION	SUBCOM
CONSENT OF SURETY COMPANY TO FINAL PAYMENT	CONSUR
OWNER’S MINIMUM PROJECT WORK RULES	PWR-1 TO PWR-2
OWNER’S SAFETY GUIDELINES	PSG-1 TO PSG-3
PERFORMANCE BOND	PB-1 TO PB-4
STATUTORY PAYMENT BOND	SPB-1 TO SPB-3

SCOPE OF WORK

SCOPE OF WORK	1 TO 5
---------------	--------

ATTACHMENTS

- 01 – TALLEYRAND MARINE TERMINAL DRAWINGS
- 02 – HOW TO SUBMIT YOUR BID RESPONSE IN E-BUILDER

(THE REMAINDER OF THIS PAGE IS BLANK INTENTIONALLY)

SECTION I - REQUEST FOR PROPOSAL OVERVIEW AND RESPONSE PROCEDURES

A. INTRODUCTION

JAXPORT is requesting Qualifications, Technical and Price Proposals from interested firms (Proposers) with qualified experience in Design-Build, to design, permit, furnish, and construct a pre-engineered metal building at JAXPORT's Talleyrand Marine Terminal, utilizing their best skill and expertise to perform the following services and tasks: design, construction, project management, and permitting from all Authorities Having Jurisdiction (AHJ), if needed, and any other service or task manifestly required to render a complete and useable project.

The scope of work will include, but is not necessarily limited to footings/foundations, steel framing/structure, metal roofing, metal siding (walls), power, lighting, grounding, roof vent system, lightning protection system (if required by Code), reinforced concrete floor, gutters and downspouts. This project will be awarded utilizing an Adjusted Score Design-Build delivery method.

B. RECEIPT AND OPENING OF PROPOSALS

The RFP package (**Qualifications and Technical Proposal**) will be received by Procurement Services until **2:00 PM (EST) (EST)**, on **WEDNESDAY, SEPTEMBER 22, 2021**, at which time they shall be opened via "Go to Meeting" at:

<https://global.gotomeeting.com/join/394014709>, Access Code: **394-014-709**

and

The RFP package (**Price Proposal**) will be received by Procurement Services until **2:00 PM (EST)**, on **FRIDAY, OCTOBER 1, 2021**, at which time they shall be opened via "Go to Meeting" at:

<https://global.gotomeeting.com/join/183149061>, Access Code: **183-149-061**

Note: ONLY competitive range qualified proposers will be invited, under a separate invitation key, to submit a price proposal

C. MANDATORY PRE-PROPOSAL

To ensure that all Proposers are fully informed of the requirements for this Contract, a Mandatory Pre-Proposal meeting will be held on **TUESDAY, SEPTEMBER 7, 2021** at **10:00 AM (EST)**, via "Go to Meeting" at:

<https://global.gotomeeting.com/join/347116797>, Access Code: 347-116-797

An optional SITE VISIT of the facility may be scheduled at the request of interested contractors.

Failure to attend the MANDATORY Pre-Proposal will result in rejection of Proposal.

D. TWO-STEP SELECTION PROCESS

JAXPORT shall conduct a two-step selection process. In the first step, JAXPORT will evaluate the Proposer's Qualifications to create a competitive range of the most qualified Proposers. JAXPORT will determine a competitive range by assuring that all Proposers meet the below qualifications listed. JAXPORT will then evaluate only those Technical Proposals submitted by the competitive range qualified Proposers. Proposers will be ranked by the Evaluation Committee based upon which competitive range qualified Proposer has the highest score. The maximum possible score is 100 points.

In the second step, JAXPORT will publicly open the Price Proposals submitted by the competitive range qualified Proposers on the dates set forth in the Public Notice. Proposers will be ranked by Procurement Services based upon which Proposer has the lowest adjusted score.

1. Step One: Qualifications and Technical Proposals

(a) Qualifications Criteria – PASS/FAIL Evaluation

Qualifications will be evaluated in accordance with the Selection Criteria set forth in the Qualification Criteria section. Proposers shall structure the response documentation in a manner to properly and clearly address each of the Qualification Selection Criteria sections below and its relevant requirements. It is the sole responsibility of each Proposer to address each of the Qualification Selection Criteria and its relevant requirements. When in doubt as to any requirement or criteria, submit written questions by the question deadline.

The Qualifications will be evaluated "PASS/FALL" by JAXPORT's Evaluation Committee based on the criteria detailed in the table below. SOQs must receive a passing evaluation on every criterion to be considered responsive.

Statement of Qualifications Evaluation Criteria	PASS/FAIL
<p>A. Proposer’s History</p> <p>Summarize Proposer’s history, length of time in the construction business, types of services offered and direct experience in providing design-build services over the past five (5) years.</p>	PASS/FAIL
<p>B. Proposer’s Engineer of Record</p> <p>Identify the individual (and their employer if not an employee of Proposer) who will serve as Engineer of Record for design of the project. The Engineer of Record shall be a Professional Engineer licensed in the State of Florida. Demonstrate that this individual has at least five (5) years of experience providing engineering services for design of projects of similar scope and size.</p>	PASS/FAIL
<p>C. Licensed Contractor</p> <p>Identify the construction contractor and provide their Florida contractor’s license number. Provide evidence that the contractor has erected metal building systems (including site prep and utilities) in the past five (5) years.</p>	PASS/FAIL
<p>D. Project Staffing</p> <p>Provide an organizational chart showing all key personnel and key subcontractors proposed for the work. Include resumes for the project manager and superintendent. Resumes may not exceed two (2) pages per individual. Resumes should identify each individual’s firm, the individual’s qualifications for their assigned role, and document that the individual possesses experience in design-build of metal building systems.</p>	PASS/FAIL
<p>E. Experience Modification Rate (EMR)</p> <p>List your firms EMR for the last three (3) years and provide documentation. Proposer’s average EMR over the past three (3) years must be less than 1.3. Proposer’s with an average EMR greater than 1.3 will be disqualified.</p>	PASS/FAIL

(b) Technical Proposal Criteria

Technical Proposals will be evaluated in accordance with the Selection Criteria set forth in the Technical Proposal Criteria section. Proposers shall structure the Proposal in a manner to properly

and clearly address each of the Technical Selection Criteria and its relevant requirements. It is the sole responsibility of each Proposer to address each of the Technical Selection Criteria and its relevant requirements. When in doubt as to any requirement or criteria, submit written questions by the question deadline.

A Written Technical Proposal (WTP) will include items such as a detailed project site concept and design, budget and schedule, staffing plan, submittals, timeline, permit requirements, total Contract time and other data requested in the RFP. The package containing the WTP shall indicate clearly that it is the Technical Proposal and shall identify clearly the Proposer's name in the electronically submitted documents. The Proposer must not discuss or reveal elements of its Price Proposal in its WTP.

- Upon completion of the Qualifications being evaluated "PASS/FAIL, the Evaluation Committee will review and evaluate only WTPs receiving a "PASS" and if necessary, request Oral Presentations from those Proposers. The purpose of the Oral Presentation is to assist the Evaluation Committee with any clarification and/or to ask questions, as it relates to the WTP of the Proposer. Proposers will not be permitted to ask questions of the Evaluation Committee except to clarify the meaning of a question posed by the Evaluation Committee.
- A perfect score for the WTP Evaluation Criteria is 100 points. At the completion of the evaluation of all Written Technical Proposals (Oral Presentation, if necessary), each member of the Evaluation Committee will submit total scores which will be the Final Technical Score assigned to each Proposer.

The Technical Proposals submitted by the competitive range qualified will be evaluated and scored by JAXPORT's Evaluation Committee, based on the criteria detailed in the table below. The maximum possible score is 100 points.

Technical Proposals Evaluation Criteria	Points Value
<p>A. Project Approach</p> <p>Proposer shall provide a detailed discussion and plan of Proposer’s approach to the project that includes, but is not limited to, design and installation of metal building systems, proposed foundation and site issues, design and installation of utilities, maintenance of traffic, work sequencing, permitting requirements, and coordination plans.</p>	60
<p>B. Schedule</p> <p>Proposer shall discuss its preliminary schedule for design and construction of the project. The schedule should demonstrate an understanding of operational and site constraints, long-lead time material procurements, and coordination with JAXPORT reviews.</p>	15
<p>C. Safety</p> <p>Proposer shall discuss its safety plan for the construction phase. Provide examples where the safety plan has been successfully implemented on past projects.</p>	15
<p>D. Quality Control</p> <p>Proposer shall discuss its design and construction quality control processes. Include information on how these processes were successfully implemented on past projects. Also, discuss the designer’s processes to ensure design does not exceed budget.</p>	10
TOTAL	100 Points

2. Step Two: Price Proposals

Price Proposals will be based on a firm fixed price for the various design and construction elements of the Project as identified on the Price Proposal Form included in the RFP. The package containing the Price Proposals shall indicate clearly that it is the Price Proposal and shall identify the Proposer's name in the electronically submitted documents. JAXPORT will publicly open the Price Proposals submitted by the competitive range qualified Proposers on the dates set forth in the Public Notice.

-
- On the date and time for the opening of Price Proposal submissions, a public meeting will be held, in which Procurement Services will announce the Evaluation Committee's Final Technical Score for each Proposer (Maximum 100 points). Following the announcement of the average Final Technical Scores, the Price Proposals will be opened and announced. Price Proposals must then be verified to ensure calculations are accurate for all line items. Once all Price Proposal calculations are verified, Procurement Services will tabulate the average FTS's and Price Proposal amount using the formula listed below, in order to determine the Proposer with the lowest Adjusted Score (AS).

$$\frac{\text{Price Proposal (PP)}}{\text{Final Technical Score (FTS)}} = \text{Adjusted Score (AS)}$$

- Procurement Services will then publicly announce the Adjusted Scores for all Proposers. The Proposer to be recommended for award of this Project will be that Proposer whose Adjusted Score is the lowest amongst all Proposers, as long as the Proposer's Price is within the engineer's estimate. If the Proposer with the lowest Adjusted Score is not within the engineer's estimate, then JAXPORT reserves the right to negotiate the price proposal with the Proposer, having the lowest Adjusted Score. If negotiations fail to bring the Project within the engineer's estimate, then JAXPORT reserves the right to move to the next Proposer with the second lowest Adjusted Score. If the Proposer with the second lowest Adjusted Score is not within the engineer's estimate and if negotiations fail to bring the project within said estimate then JAXPORT reserves the right to move to the next Proposer with the third lowest Adjusted Score. Procurement Services has the right to correct any errors in the evaluation and selection process that may have been made. JAXPORT is not obligated to award the Contract and may decide to reject all Proposals.
- It is the intent of JAXPORT to award this Contract to the Proposer who, in its sole opinion, is the most qualified and capable of providing the best overall service consistent with the goals, objectives and budget of JAXPORT. JAXPORT reserves the right to waive informalities in any Proposal, to reject any or all Proposals received in response to the RFP, with no liability to JAXPORT for rejection of any Proposal for any reason.

Example of Adjusted Score Calculation

<u>Proposer #1</u>	<u>Proposer #2</u>	<u>Proposer #3</u>
PP: \$500,000	PP: \$510,000	PP: \$495,000
FTS: 97	FTS: 93	FTS: 94
AS: 5,155	AS: 5,484	AS: 5,266

Proposer #1, having the lowest Adjusted Score, would be ranked first, followed by Proposer #3, then Proposer #2.

E. SUBCONTRACTORS/JOINT VENTURES

JAXPORT will award a contract to one (1) Proposer, who shall be the Design Consultant / Prime Contractor and the single point of contact between JAXPORT and the Proposer. The successful Proposer shall be fully responsible and bound for the Work described in this RFP. JAXPORT neither encourages, nor discourages, the formation of teams, as long as team members are subcontractors to the Design Consultant / Prime Contractor. It is the desire of JAXPORT that the work elements required by the Project and included in the negotiated agreement is shared with other qualified area subcontractors to the extent that such goal does not diminish the selection of the most qualified Design Consultant / Prime Contractor. **Joint Ventures will not be considered.**

F. SMALL & EMERGING BUSINESS (SEB) PARTICIPATION GOAL

JAXPORT has determined that the SEB participation is 100 percent (%) JSEB/DBA/SBA/MBE/WBE for this project. SEB participation in the specified percentage must be met in order to satisfy this requirement, or good faith efforts submitted to demonstrate why the goal could not be achieved, in accordance with ARTICLE V, Section 5.10.

Contractors will take all necessary affirmative steps to ensure that minority firms, women's business enterprises, and labor surplus area firms are used when possible.

- Small Business Firms – Designated by the Small Business Administration.
- Minority Business Firms – 51% Minority Owner/Operated.
- Women's Business Enterprises – Small business that is at least 51% owned by a woman or women.
- Labor Surplus Area Firms – Firms geographically located in distressed labor surplus areas designated by the Secretary of Labor

Contractors shall ensure the following actions are taken in dealing with the above listed firms:

1. Placement on Bidders List;
2. Ensuring that solicitations are mailed;
3. Allocating requirements into smaller amounts, when feasible, to permit maximum participation;
4. Establishing delivery requirements, when feasible, for compatibility with capability of the above-listed firms;
5. Using the services of the Small Business Administration, and
6. When subcontracts are considered, the Contractors will take these steps (1-5) for subcontracts.

G. REQUEST FOR PROPOSAL - SCHEDULE OF EVENTS

It is anticipated that the following schedule will remain but is subject to changes:

	SCHEDULE OF EVENTS	DATE
1	Release RFP to General Public	Wednesday, August 25, 2021
2	Mandatory Pre-Submission Meeting, "10:00 AM"	Tuesday, September 7, 2021
3	Deadline for Questions, "12:00 PM"	Friday, September 10, 2021
4	Receipt of RFP Package (SOQ/Technical Proposal), "2:00 PM"	Wednesday, September 22, 2021
5	Oral Presentation/Interviews (if necessary)	TBD
6	Receipt of RFP Package (Price Proposal), "2:00 PM"	Friday, October 1, 2021
7	Recommendation for Award Notification	Monday, October 4, 2021
8	Awards Committee Review	October 20, 2021
9	Issue and Execute Agreement	TBD
10	Issue Notice to Proceed	TBD

H. CONTACT PERSON

Questions regarding this RFP must be submitted in writing to: Sandra Platt, Sr. Contract Specialist of Procurement Services, via email; sandra.platt@jaxport.com. The answers will be in the form of an addendum posted via website link: <https://www.jaxport.com/procurement/active-solicitations/> or e-

mailed directly to all known prospective Proposers. The deadline for submitting questions will be **FRIDAY, SEPTEMBER 10, 2021 at 12:00 PM (EST).**

I. OMISSIONS, DISCREPANCIES AND ADDENDA

Should an omission or discrepancy be found in the RFP documents, or if there is any doubt as to the meaning, the Proposer shall notify JAXPORT Procurement Services, in writing, in sufficient time in order for an addendum to be issued to all prospective Proposers, if necessary.

- a. Any addenda issued by JAXPORT for the purposes of changing the intent of the RFP or to clarify the meaning of same shall be binding in the same way as if written in the specifications. All addenda will be issued by Procurement Services prior to the receipt of the RFP package (SOQ and Technical Proposal). It is each proposer's sole responsibility to contact Procurement Services to insure that they have received all addenda and that they have obtained the addenda in sufficient time to properly evaluate the contents before submitting an RFP Package (SOQ, Technical and Price Proposals). It is the usual practice for JAXPORT to email addenda to known prospective Proposers, but JAXPORT does not guarantee that all prospective Proposers will receive addenda in this manner in due time before the RFP package (SOQ and Technical Proposal) deadline.
- b. It is mandatory that the Proposers shall acknowledge the inclusion of all addenda on the signature page. Acknowledgement shall be by initials and date. **Failure to acknowledge all addenda shall result in rejection of the Proposers RFP package.**

PLEASE VISIT <https://www.jaxport.com/procurement/active-solicitations/> OR CALL THE PROCUREMENT SERVICES DEPARTMENT AT (904) 357-3017, PRIOR TO THE SUBMITTAL DATE TO DETERMINE IF ANY ADDENDA HAVE BEEN RELEASED ON THIS RFP.

(THE REMAINDER OF THIS PAGE IS BLANK INTENTIONALLY)

SECTION II – REQUEST FOR PROPOSAL SUBMISSION, FORMAT AND BONDS

A. PROPOSAL SUBMISSION

Statements of Qualification, Technical Specification and Price Proposal and all required supplemental material as described in “Proposer Contents and Format”, must be submitted in **PDF Format Only** through E-Builder. RFP packages and supplemental documents submitted through Email or Fax will not be accepted or considered. **Until further notice, JAXPORT is *not* accepting any RFP packages submitted by Mail or Hand-Deliveries due to the current COVID-19 situation. Please visit JAXPORT’s website at www.jaxport.com for more information and updates.**

The RFP package (SOQ and Technical Proposal) PDF file name should read **“C-1752 Terminal Facilities Building – SOQ and Technical Proposal”**

**SOQ’S AND TECHNICAL PROPOSALS MUST BE SUBMITTED THROUGH E-BUILDER,
PRIOR TO 2:00 PM (EST), WEDNESDAY, SEPTEMBER 22, 2021**

The RFP package (Price Proposal) PDF file name should read **“C-1752 Terminal Facilities Building – Price Proposal”**

PRICE PROPOSALS MUST BE SUBMITTED THROUGH E-BUILDER,

Note: ONLY competitive range qualified proposers will be invited, under a separate invitation key, to submit a price proposal

PRIOR TO 2:00 PM (EST), FRIDAY, OCTOBER 1, 2021

“How to Submit Your Bid Response in E-Builder” is provided as **Attachment “02”** Additional instructions on how to navigate in E-Builder, click the below link to access the **“Bidders Portal Instructional Training Video”**:

<https://resources.e-builder.net/bidding/e-builder-bidders-portal-instructional-training-video>

RFP package (SOQ and Technical Proposal) must be submitted prior to **2:00 PM (EST), WEDNESDAY, SEPTEMBER 22, 2021** and RFP package (Price Proposal) must be submitted prior to **2:00 PM (EST), FRIDAY, OCTOBER 1, 2021**. The submit button in E-Builder will deactivate exactly at 2:00 PM (EST) and you will not be permitted to submit your proposal regardless of where you are in the process. Please plan accordingly.

Any Proposals received after the above stated time and date will not be considered. It is the sole responsibility of the Proposer to have its Proposal submitted to JAXPORT as specified herein on or

before the above date and time. For the purpose of the RFP, a proposal is considered delivered when confirmation of delivery is provided by E-Builder. Proposer's must ensure that its electronic submission in E-Builder can be assessed and viewed at the time of the proposal opening. JAXPORT will consider any file that cannot be immediately accessed and viewed at the time of the proposal opening (such as, encrypted files, password protected files, or incompatible files) to be blank or incomplete as context requires, and are therefore unacceptable. Proposer's will not be permitted to unencrypt files, remove password protections, or resubmit documents after proposal opening to make a file viewable if those documents are required with proposal. All expenses for submitting Proposals to JAXPORT are to be borne by the Proposer and will not be borne, charged to or reimbursed by JAXPORT in any manner or under any circumstance.

The SOQ cover letter shall clearly indicate the legal name, address, and telephone number of the Proposer (corporation, firm, partnership, individual, or sole proprietorship). The RFP shall be signed above the typed or printed name and title of the signer. The SOQ and Price Proposal must be signed by an individual with the authority to bind the Proposer. The signature of the Authorized Representative on the both packages must be made by an officer of the Proposer if the Proposer is a corporation, by a partner if the Proposer is a partnership, or by the proprietor, if the Proposer is a sole proprietorship.

B. QUALIFICATION PROPOSAL FORMAT

The Qualification's shall be a maximum of Ten (10) 8-1/2 inch x 11 inch pages, exclusive of a one (1) page cover letter. Respondents can include 11 inch x 17 inch "z-fold" in the Qualification's submittal. The "z-fold" will be primarily graphics and will be counted as one (1) page. Text shall be a minimum font size of ten (10).

Submittals must contain the following documents, each fully completed, and signed as required. If any items are omitted, JAXPORT has the right to clarify and request information from any Proposer. The Proposer must submit the documentation no later than **three (3) calendar days** after request from JAXPORT, or the Qualification's may be deemed non-responsive.

Documents to be completed and returned with qualifications:

1. Copies of current license(s) for Design Consultant / Prime Contractor business.
2. Copy of current registration with the Florida Department of State, www.sunbiz.org.

-
3. Furnish best evidence of the Proposer most recent Financial Statement. An audited financial report reflecting the Proposer current financial status is preferred. If no audited financial report exists, the JAXPORT may accept a certified financial statement, most recent balance sheet, income statement, and statement of cash flows prepared internally, approved and attested to by the Proposer's President or Chief Executive Officer. If the financial statements are more than 180 days old, the Proposer shall include evidence signed by an officer of the firm as to current financial condition in relation to the most recent reporting period.
 4. Exhibit "A" - Conflict of Interest, COI Form
 5. Exhibit "B" - Sworn Statement/Section 287.133(3)(a), Florida Statutes - Public Entity Crime, PEC Form
 6. Exhibit "C" - E-Verify Program for Employment Verification, E-Verify Form
 7. Acknowledgement of all addenda, Signature Page.

C. TECHNICAL PROPOSAL FORMAT

The Written Technical Proposal shall be a maximum of thirty (30) 8-1/2 inch x 11 inch pages for all four (4) sections of evaluation criteria listed below. Respondents can include 11 inch x 17 inch "z-fold" in the RFP submittal. The "z-fold" will be counted as one (1) page. Text shall be a minimum font size of ten (10). The Written Technical Proposal should include bold capitalized headings for each Technical Evaluation Criteria A thru D for ease of review by the Evaluation Committee Members.

D. ORAL PRESENTATIONS/INTERVIEWS (IF NECESSARY)

The Evaluation Committee has the option to have each competitive range qualified Proposer / Consultant Team, formally present their material from the WTP in an Oral Presentation / Interview. The purpose of the Oral Presentation / Interview is for the competitive range qualified Proposer / Consultant Team to present their Project Approach, as submitted in the Written Technical Proposal, and to allow the Evaluation Committee the opportunity to seek clarification and ask questions as it relates to the Written Technical Proposal of the Proposer / Consultant Team. Once the responses to the Evaluation Criteria of this RFP are received, JAXPORT will issue an Agenda including time frames for each criteria, to the firms who are determined to be in the competitive range for the Oral Presentations and Interviews.

E. PRICE PROPOSAL / BONDS

The Price Proposals shall be submitted on the Price Proposal Form attached hereto (PPF-1 through PPF-3) and shall include a total lump sum price for the design and construction of a pre-engineered metal building at JAXPORT's Talleyrand Marine Terminal. The total lump sum price shall include all costs for design, construction, project management, and permitting from all Authorities Having Jurisdiction (AHJ), if needed, and any other service or task manifestly required to render a complete and useable project. Travel expenses will not be reimbursed.

Authentication of Proposal Form – All Price Proposals submitted for this contract shall be signed as outlined below. **FAILURE ON THE PART OF THE INDIVIDUAL, PARTNERSHIP OR CORPORATION TO SIGN THE PRICE PROPOSAL FORM, WILL CONSTITUTE A MATERIAL IRREGULARITY AND SHALL RESULT IN THE REJECTION OF THE RFP.**

- If made by an individual, Form PPF shall show the name and business address of the individual or firm and shall be signed by the individual or authorized representative of the individual.
- If made by a partnership, Form PPF shall show the name and business address of the partnership and shall be signed by a partner or authorized representative of the partnership.
- If made by a corporation, Form PPF shall show the name and business address of the corporation and shall be signed by an officer or an authorized representative of the corporation.

Bid Bond - Each Proposer shall furnish with the Price Proposal a bid bond in an amount not less than 5 percent of the total bid amount, as a guaranty that the bid will not be withdrawn for a period of 90 calendar days after opening of Price Proposals. As soon as practicable after opening of proposals, any check submitted as guaranty by other than the first two lowest score conforming Proposers will be returned. Any such checks submitted by the remaining two Proposers will be returned after execution of the Agreement and submittal of a contract bond by the successful Proposer. If a bid bond is used, it shall be written through a Surety bond agency and with a Surety company meeting the same specifications as those required for contract bonds.

The bid bond provided by the Owner of the Property/Contracting Public Entity may be utilized (see Form BBF). Surety's standard bond form for State of Florida is acceptable. Refer also to "Surety Bonds" of the "General Conditions."

If a contract bond is not furnished within the time stated herein, the bid guaranty will be forfeited and the contract may be awarded to the next lowest score conforming Proposer. THE BID BOND MUST BE SECURED FROM AND EXECUTED BY AN AGENCY DULY-LICENSED TO DO BUSINESS IN THE STATE OF FLORIDA, PURSUANT TO CHAPTER 255 OF THE FLORIDA STATUTES, SECTION 255.05. FAILURE TO FURNISH THE BID GUARANTY, INCLUDING POWER OF ATTORNEY, IF REQUIRED, WILL CONSTITUTE A MATERIAL IRREGULARITY AND SHALL RESULT IN THE REJECTION OF THE REQUEST FOR PROPOSAL.

Payment & Performance Bond - The Contractor, at its own expense, shall furnish a Performance Bond, and a Statutory Payment Bond as security for the faithful performance under the contract documents. The bonds shall be in an amount at least equal to the contract price, in the form provided in these contract documents, and with such Surety as is acceptable to the Owner. Such bonds shall indemnify the Owner for damages associated with unexcused late delay of the project. JAXPORT Payment and Performance Bond Forms are provided in this RFP.

Florida State Sales Tax - It is the Proposer's sole responsibility to incorporate any and all applicable taxes into the bid. However, Chapter 212 of the Florida Statutes provides the Jacksonville Port Authority with sales tax exemption for all procurements made directly by JAXPORT.

(THE REMAINDER OF THIS PAGE IS BLANK INTENTIONALLY)

SECTION III – LEGAL TERMS AND CONDITIONS/INSURANCE

A. MODIFICATION/WITHDRAWALS OF SUBMITTALS

The Proposer may submit a modified response to replace all or any portion of a previously submitted response up until the RFP due date and time. Modifications received after the RFP due date and time will not be considered. Responses shall be irrevocable until Contract award unless withdrawn in writing prior to the RFP due date or after expiration of 120 calendar days from the opening of responses without Contract award.

B. RFP POSTPONEMENT/CANCELLATION/REJECTION

JAXPORT may, at its sole and absolute discretion, reject any and all, or parts of any and all, responses; re-advertise this RFP; postpone or cancel, at any time, this RFP process or waive any irregularities in this RFP or in any responses received as a result of this RFP.

C. COST INCURRED BY PROPOSERS

All expenses incurred by Proposer with the preparation and submission of responses to JAXPORT for this RFP, or any work performed in connection there with, shall be the sole responsibility of the Proposer and not be reimbursed by JAXPORT.

D. PUBLIC MEETING REQUIREMENTS

JAXPORT complies with Section 286.011 of the Florida Statutes. Therefore, certain types of staff meetings and meetings of JAXPORT's Awards Committee and Board of Directors are required to be held in public, with sufficient notice made of the time and date of the meeting(s). All notices of public meetings are posted in the lobby of JAXPORT, 2831 Talleyrand Avenue, Jacksonville, Florida 32206 and on JAXPORT's website at www.jaxport.com. For information concerning when the project(s) will be submitted for award, contact JAXPORT's Procurement Services at telephone (904) 357-3017, Monday through Friday.

E. PUBLIC RECORDS

In accordance with Section 119.0701, Florida Statutes, the Contractor shall:

- (a) Keep and maintain public records required by JAXPORT to perform the services; and

-
- (b) Upon request from JAXPORT’s custodian of public records, provide JAXPORT with a copy of the requested records or allow records to be inspected or copied within a reasonable time at a cost that does not exceed the cost provided for in Chapter 119, Florida Statutes, or as otherwise provided by law; and
 - (c) Ensure that public records that are exempt or confidential and exempt from public records disclosure requirements are not disclosed except as authorized by law for the duration of the Contract term and following completion of this Contract if Contractor does not transfer the records to JAXPORT; and
 - (d) Upon completion of this Contract, transfer to JAXPORT at no cost all public records in possession of Contractor or keep and maintain public records required by JAXPORT to perform the service. If Contractor transfers all public records to JAXPORT upon completion of this Contract, Contractor shall destroy any duplicate public records that are exempt or confidential and exempt from public records disclosure requirements. If Contractor keeps and maintains public records upon completion of this Contract, Contractor shall meet all applicable requirements for retaining public records. All records stored electronically must be provided to JAXPORT upon request from JAXPORT’s custodian of public records in a format that is compatible with JAXPORT’s information technology systems.

The above requirements apply to a “Contractor” as defined in Section, 119.0701, Florida Statutes.

IF CONTRACTOR HAS QUESTIONS REGARDING THE APPLICATION OF CHAPTER 119, FLORIDA STATUTES, IT IS THE CONTRACTOR’S DUTY TO PROVIDE PUBLIC RECORDS RELATING TO THIS CONTRACT. CONTACT JAXPORT’S CUSTODIAN OF PUBLIC RECORDS AT (904) 357-3091 public.records@jaxport.com; JACKSONVILLE PORT

AUTHORITY, PUBLIC RECORDS REQUEST, 2831 TALLEYRAND AVENUE, JACKSONVILLE, FLORIDA 32206.

F. PROTEST PROCEDURES

Respondents shall file any protest regarding this RFP in writing, in accordance with JAXPORT's Protest Procedures promulgated on SOP-1215 Procurement Code for the Jacksonville Port Authority, available at <https://www.jaxport.com/procurement/procurement-team/>

G. RULES; REGULATIONS; LICENSING REQUIREMENTS

Proposers are expected to be familiar with and comply with all Federal, State and local laws, ordinances, codes, and regulations that may in any way affect the services offered. Ignorance on the part of the Proposer will in no way relieve it from responsibility for compliance.

H. CONFLICT OF INTEREST

Pursuant to Chapter 112 of the Florida Statutes, Proposers are required to complete and submit a "Conflict of Interest" certificate. **Form CONFLICT OF INTEREST, (Exhibit "A") must be included in the RFP package "SOQ and Technical Proposal" at the time the package is submitted.** All Proposers must disclose with their response the name(s) of any officer, director, agent, or immediate family member (spouse, parent, sibling, and child) who is also an employee of JAXPORT. Further, all Proposers must disclose the name of any JAXPORT employee who owns, either directly or indirectly, an interest of ten percent (10%) or more.

I. PUBLIC ENTITY CRIME

Pursuant to Chapter 287 of the Florida Statutes, Proposers are required to complete and submit with their SOQ's a Sworn Statement Pursuant to Section 287.133 (3) (a), Florida Statutes, on Public Entity Crimes. **Form PUBLIC ENTITY CRIME (PEC), (Exhibit "B") must be included in the RFP package "SOQ and Technical Proposal" at the time the package is submitted.**

A person or affiliate placed on the convicted vendor list following a conviction for a public entity crime is prohibited from doing any of the following for a period of 36 months from the date of being placed on the convicted vendor list:

- Submitting a bid on a contract to provide any goods or services to a public entity;

-
- Submitting a bid on a contract with a public entity for the construction or repair of a public building or public work;
 - Submitting bids on leases of real property to a public entity;
 - Being awarded or performing work as a contractor, supplier, subcontractor, or consultant under a contract with any public entity; and
 - Transacting business with any public entity in excess of Category Two threshold amount (\$35,000) provided in section 287.017 of the Florida Statutes.

J. DISCRIMINATORY VENDOR LIST

An entity or affiliate placed on the discriminatory vendor list pursuant to section 287.134 of the Florida Statutes may not:

- Submit a bid on a contract to provide any goods or services to a public entity;
- Submit a bid on a contract with a public entity for the construction or repair of a public building or public work;
- Submit bids on leases of real property to a public entity;
- Be awarded or perform work as a contractor, supplier, subcontractor, or consultant under a contract with any public entity; or
- Transact business with any public entity.

To view a current list, visit:

http://dms.myflorida.com/business_operations/state_purchasing/vendorinformation/convicted_suspended_discriminatory_complaints_vendor_lists

K. PROPOSERS REPRESENTATION AND AUTHORIZATION

In submitting qualifications, technical and price proposal's, each Proposer understands, represents, and acknowledges the following (if the Proposer cannot so certify to any of the following, the Proposer shall submit with its response a written explanation of why it cannot do so).

- The Proposer is not currently under suspension or debarment by the State of Florida or any other governmental authority.

-
- To the best of the knowledge of the person signing the bid documents, the Proposer, its affiliates, subsidiaries, directors, officers, and employees are not currently under investigation by any governmental authority and have not in the last ten (10) years been convicted or found liable for any act prohibited by law in any jurisdiction, involving conspiracy or collusion with respect to bidding on any public contract.
 - Proposer currently has no delinquent obligations to the State of Florida, including a claim by the State for liquidated damages under any other contract.
 - The RFP's submission is made in good faith and not pursuant to any agreement or discussion with, or inducement from, any firm or person to submit a complementary or other noncompetitive response.
 - The Proposer has fully informed JAXPORT in writing of all convictions of the firm, its affiliates (as defined in section 287.133(1)(a) of the Florida Statutes), and all directors, officers, and employees of the firm and its affiliates for violation of state or federal antitrust laws with respect to a public contract for violation of any misrepresentation with respect to a public contract. This includes disclosure of the names of current employees who were convicted of contract crimes while in the employ of another company.
 - The product(s) offered by the Proposer will conform to the specifications without exception.
 - The Proposer has read and understands the Contract terms and conditions, and the submission is made in conformance with those terms and conditions.
 - If an award is made to the Proposer, the Proposer agrees that it intends to be legally bound to the Contract that is formed with JAXPORT.
 - The Proposer has made a diligent inquiry of its employees and agents responsible for preparing, approving, or submitting the RFP, and has been advised by each of them that he or she has not participated in any communication, consultation, discussion, agreement, collusion, act or other conduct inconsistent with any of the statements and representations made in the submittal.
 - The Proposer shall indemnify, defend, and hold harmless JAXPORT, its Board of Directors and its employees against any cost, damage, or expense which may be incurred or be caused by any error in the respondent's preparation of its submittals.

-
- All information provided by, and representations made by, the Proposer are material and important and will be relied upon by JAXPORT in awarding the Contract. Any misstatement shall be treated as fraudulent concealment from JAXPORT of the true facts relating to submission of the qualifications, technical and price proposals. A misrepresentation shall be punishable under law, including, but not limited to, Chapter 817 of the Florida Statutes.
 - That the Proposer has carefully examined the site of the work and that from his/her investigations is satisfied as to the nature and location of the work, the kind and extent of the equipment and other facilities needed for the performance of the work, the general and local conditions, all difficulties to be encountered, and all other items which in any way affect the work or its performance.
 - That the Proposer is in full compliance with all federal, state, and local laws and regulations and intends to fully comply with same during the entire term of the Contract.

L. SCRUTINIZED COMPANIES – ACTIVITIES IN SUDAN AND/OR IRAN

Section 287.135 of the Florida Statutes prohibits agencies from contracting with a company on the Scrutinized Companies with Activities in Sudan List or on the Scrutinized Companies with Activities in the Iran Petroleum Energy Sector List, lists created pursuant to section 215.473, Florida Statutes, for goods or services over \$1,000,000. Proposers are required to complete and submit with their RFP a Contractor Certification Regarding Scrutinized Companies, **Form CCRSC (Exhibit “D”) is provided in the RFP documents for that purpose and must be included with the RFP package “SOQ and Technical Proposal” at the time the package is submitted.**

Proposers must certify that it is not listed on either the Scrutinized Companies with Activities in Sudan List or the Scrutinized Companies with Activities in the Iran Petroleum Energy Sector List, created pursuant to section 215.473, Florida Statutes. Pursuant to section 287.135(5), F.S., Contractor agrees JAXPORT may terminate this contract immediately without penalty if the Contractor is found to have submitted a false certification or if Contractor is placed on the Scrutinized Companies with Activities in Sudan List or the Scrutinized Companies with Activities in the Iran Petroleum Energy Sector

M. E-VERIFY PROGRAM FOR EMPLOYMENT VERIFICATION

The successful Proposer agrees to utilize the U.S. Department of Homeland Security’s E-Verify

system to verify the employment eligibility of all new employees hired by the Proposer during the term of this Contract. Successful Proposer must include in all subcontracts the requirement that subcontractors performing work or providing goods and services utilize the E-Verify system to verify the employment eligibility of all new employees hired by the subcontractor during the Contract term. The successful Proposer further agrees to maintain records of its participation and compliance and its subcontractor's participation and compliance with the provisions of the E-Verify program, and to make such records available to JAXPORT upon request. Failure to comply with this requirement will be considered a material breach of the Contract. **Form E-VERIFY PROGRAM FOR EMPLOYMENT VERIFICATION (Exhibit "C") must be included in the RFP package "SOQ and Technical Proposal" at the time the package is submitted.**

N. RELATION TO JAXPORT

It is the intent of the parties hereto that the successful Proposer be legally considered to be an independent proposer and that neither the Proposer nor the Proposer's employees and agents shall, under any circumstances, be considered employees or agents of JAXPORT.

O. CONFORMITY TO APPLICABLE LAWS

The Proposer must comply with all applicable federal, state and local laws, rules and regulations as the same exist and as may be amended from time to time, including, but not limited to, the "Public Records Law", Chapter 119, Florida Statutes (the Public Records Act) and Section 286.011, Florida Statutes, (the Florida Sunshine Law). If any of the obligations of this Contract are to be performed by a Subcontractor, the provisions of this Section shall be incorporated into and become a part of the subcontract.

P. CONTINGENT FEES PROHIBITED

The Proposer must warrant that it has not employed or retained a company or person, other than a bonafide employee or subcontractor, working in his employ, any fee, commission, percentage, gift or other consideration contingent upon or resulting from the award of making a contract with JAXPORT.

Q. WAIVER OF IRREGULARITIES

JAXPORT may waive minor informalities or irregularities in the RFP package received where such is merely a matter of form and not substance, and the correction or waiver of which is not prejudicial to other Proposers Teams. Minor irregularities are defined as those that will not have an adverse effect

on JAXPORT's interest and will not affect the review of the RFP package by giving a Proposers Team an advantage or benefit not enjoyed by other Proposers.

R. INDEMNIFICATION

The successful Proposer will be required to agree to indemnify and hold harmless JAXPORT, the Board of Directors, its officers, employees, and agents, from and against any and all actions, claims, liabilities, losses and expenses, including but not limited to attorney's fees, for personal, economic or bodily injury, wrongful death, loss of or damage to property, in law or in equity, which may arise or be alleged to have arisen from the negligent acts or omissions or other wrongful conduct of the successful Proposer, its employees, or agents in connection with the performance of service pursuant to the resultant Contract; the successful Proposer shall pay all such claims and losses and shall pay all such costs and judgments which may result from any lawsuit arising from such claims and losses, and shall pay all costs expended by JAXPORT in the defense of such claims and losses, including appeals.

S. INSURANCE

The successful Proposer shall obtain, provide and maintain during the term of the Agreement the following types and amounts of insurance as follows, which shall be maintained with insurers licensed to sell insurance in the State of Florida and have a B+, VI or higher rating in the latest edition of AM Best's Insurance Guide. The insurer shall name JAXPORT as an additional insured on all liability policies required by this contract. When naming JAXPORT as an additional insured onto the Proposer policies, the insurance companies hereby agree and will endorse the policies to state that JAXPORT will not be liable for the payment of any premiums or assessments. Any exceptions to these requirements must be approved by JAXPORT's Risk Management Department.

LIMITS

General Aggregate Limit (other than Products/Completed Operations)	\$2,000,000
Products/Completed Operations Aggregate Limit	\$1,000,000

The Proposer shall continue to maintain Products/Completed Operations coverage for a period of three (3) years after the Agreement completion date. The insurance must specifically include JAXPORT, the members of its Governing Body and its officers, officials, and employees as Additional Insured,

with respect to liability arising out of services performed in connection with this Agreement. CGL coverage will be primary and non-contributory.

Business Auto Policy - The Proposer's insurance shall cover the Proposer for those sources of liability which would be covered by Part IV of the latest occurrence edition of the standard Business Auto Policy (ISO Form CA 00 01), including coverage for liability contractually assumed, as filed for use in the State of Florida by the Insurance Services Office, without the attachment of restrictive endorsements. Coverage shall include owned, non-owned, and hired autos.

The minimum limits to be maintained by the Proposer (inclusive of any amounts provided by an umbrella or excess policy) shall be \$1,000,000 per accident combined single limit for Bodily Injury Liability and Property Damage Liability.

Professional Liability - The Proposer's insurance shall be on a form acceptable to JAXPORT, and shall cover the Proposer for those sources of liability arising out of the rendering or failure to render professional services in the performance of this Agreement, including any hold harmless and/or indemnification agreement.

The minimum limits to be maintained by the Proposer (inclusive of any amounts provided by an umbrella or excess policy) shall be \$1,000,000 per occurrence, and in the aggregate.

The Proposer shall provide and maintain such professional liability insurance from the inception of its services, and until at least three (3) years after completion of all services required under this Agreement.

Prior to commencement of services, the Proposer shall provide to JAXPORT a certificate or certificates of insurance, signed by an authorized representative of the insurer(s) evidencing the insurance coverage specified in the foregoing Articles and Sections. The required certificates shall not only name the types of policies provided, but shall also refer specifically to this Agreement and Article, and to the above paragraphs in accordance with which insurance is being furnished, and shall state that such insurance is provided as required by such paragraphs of this Agreement. The required certificates shall contain a provision that JAXPORT shall be given not less than 30 days' written notice prior to cancellation or restriction of coverage. The Proposer shall also provide JAXPORT, a certified copy of the Professional Liability Insurance coverage. The required policies shall contain a provision that JAXPORT shall be given not less than 30 days' written notice prior to cancellation or restriction of coverage. If the initial insurance policies required by this Agreement expire prior to the termination

of this Agreement, renewal certificates of insurance or policies shall be furnished 30 days prior to the date of their expiration.

Property Insurance - If this contract includes construction of or additions to above ground buildings or structures, Proposer shall provide Builder's Risk insurance with the minimum amount of insurance to be 100 percent of the completed value of such addition(s), building(s) or structure(s). If the contract does not include construction of or additions to above ground buildings or structures but does involve the installation of machinery or equipment, Proposer shall provide an Installation Floater with the minimum amount of insurance to be 100 percent of the completed value of such addition(s), building(s), or structure(s). Said insurance shall be written by an insurer holding a current certificate of authority pursuant to Chapter 624, Florida Statutes. Such insurance shall be endorsed to provide for a waiver of underwriter's rights of subrogation in favor of JAXPORT. Such insurance shall be written by an insurer with an A.M. Best rating of (A, VI or better). Prior to commencing any work on the project, Certificates of Insurance approved by JAXPORT's Risk Management evidencing the maintenance of said insurance shall be furnished to JAXPORT. The certificates shall provide that no material alteration or cancellation, including expiration and non-renewal, shall be effective until thirty (30) days after receipt of written notice by JAXPORT. Anything to the contrary, notwithstanding the liabilities of the Proposer under this Agreement, shall survive and not be terminated, reduced or otherwise limited by any expiration or termination of insurance coverage's. Neither approval nor failure to disapprove insurance furnished by the Proposer shall relieve the Proposer from responsibility to provide insurance as required by contract. The Proposer is responsible for any deductibles applicable to Property Insurance.

Umbrella Liability - Proposer will provide following form umbrella coverage to the following underlying coverage's (Commercial General Liability, Pollution, Automobile liability and Workers' Compensation/Employer's Liability) the umbrella liability coverage will drop down if the underlying coverage's have been exhausted. The umbrella coverage will be \$1,000,000 per occurrence and in aggregate.

Failure of Owner to demand such certificate or other evidence of full compliance with these insurance requirements, or failure of Owner to identify a deficiency from evidence that is provided, shall not be construed as a waiver of Proposer's obligation to maintain such insurance.

If Proposer fails to maintain the required insurance, Owner shall have the right, but not the obligation, to purchase said insurance at Proposer's expense.

A waiver of subrogation is required for Workers Compensation, CGL, Auto Liability, and Pollution liability. Proposer waives all rights against Owner and its agents, officers, directors and employees for recovery of damages to the extent these damages are covered by any of the policies of insurance maintained pursuant to this Subcontract.

Prior to commencing Work, Proposer shall furnish Owner with certificates of insurance, and copies of additional insured endorsements, executed by a duly authorized representative of each insurer, showing compliance with the insurance requirements set forth below.

Cross-Liability Coverage- If Proposer's liability policies do not contain the standard ISO separation of insured's provision, or a substantially similar clause, they shall be endorsed to provide cross-liability coverage.

Subcontractor's' Insurance - Proposer shall cause each subcontractor employed by Contractor to purchase and maintain insurance of the type specified in this agreement. When requested by Owner, Contractor shall furnish to Owner copies of certificates of insurance evidencing coverage for each subcontractor Owner does not represent that coverage and limits will necessarily be adequate to protect Proposer and such coverage and limits shall not be deemed as a limitation on Contractor's liability under the indemnities provided to Owner in this Agreement.

FAILURE TO PROCURE INSURANCE:

Successful Proposer's failure to procure or maintain required insurance program shall constitute a material breach of Contract under which JAXPORT may immediately terminate the Contract.

T. EX-PARTE COMMUNICATIONS PROHIBITED

From the time of receipt, or publication of this RFP, all parties who intend to submit, or be a team member of a Proposer under this RFP, agrees to direct all contact with JAXPORT through the Sr. Contract Specialist. If the question or comment deals with subject matter that is outside of the responsibility of the Sr. Contract Specialist, he/she will ensure that the question or comment is directed to the appropriate person or authority. Proposers for the work covered by this RFP will neither contact any of the Evaluation Committee/Selection Committee, nor any member of JAXPORT's Board of Directors, nor JAXPORT Chief Executive Officer from the date of first advertisement of this RFP and

throughout the date of award by JAXPORT for purposes of discussing the merits of any specific RFP package or Proposer Team.

Any Ex-Parte communication concerning the solicitation, evaluation, and selection process denies all Proposers Teams submitting proposals fair, open, and impartial consideration. Adherence to procedures which ensure fairness is essential to the maintenance of public confidence in the value and soundness of the important process of public procurement of professional services. **Therefore, during the solicitation, evaluation, and selection process, any ex-parte communication between a Proposer, a Proposer Team, its employees, agents, or representatives, and JAXPORT, its Board of Directors, its members, employees, agents, legal counsel, or representatives, other than JAXPORT's Sr. Contract Specialist is strictly prohibited.** Failure to observe this requirement shall result in rejection of a Proposer Team's RFP package. For purposes of this section, the term "ex-parte communication" shall mean any oral or written communication relative to this solicitation, evaluation, and selection process which occurs outside of an advertised public meeting, pursuant to Section 286.011, Florida Statutes. This requirement shall not prohibit:

- a) Meeting called or requested by JAXPORT and attended by Proposer Teams for the purpose of discussing this solicitation, evaluation, and selection process, including but not limited to, substantive aspects of this RFP;
- b) The addressing of any elected or appointed governing authority of JAXPORT at public meetings advertised and conducted pursuant to, and in compliance with, Section 286.011 Florida Statutes;
- c) The filing and prosecution of a written protest to any proposed award to be made pursuant to this solicitation, evaluation, and selection process, which filing and prosecution shall give notice to all Proposer Teams. Protest proceedings shall be limited to open public meetings, with no ex-parte communication outside those meetings;
- d) Contact with appointed and elected officials of JAXPORT.

U. SECURITY IMPLEMENTATION PROCEDURE

JAXPORT's rigid security standards include the Federal Transportation Worker Identification Credential (TWIC) program, which is administered by the Transportation Security Administration. The TWIC is required for unescorted access to all JAXPORT terminals. It is your responsibility as the Prime Contractor to ensure that all of your employees and sub-contract personnel working for your

company have been properly screened and credentialed with the TWIC, and the JAXPORT Business Purpose Credential.

Transportation Worker Identification Credential (TWIC)

The TWIC is required for all Prime Contractor/Sub-Contractor employees working on the job site for this Contract. This credential is for all personnel requiring unescorted access to secure-restricted areas of Maritime Transportation Security Act (MTSA)-regulated facilities. TSA will issue a tamper-resistant “Smart Card” containing the person’s biometric (fingerprint template) to allow for a positive link between the card and the individual.

The fee for obtaining each TWIC® is \$125.25, and the credential is valid for five years. The pre-enrollment process can be initiated online at <https://universalenroll.dhs.gov/> or at an IdentoGo TSA’s Universal Enrollment Service Center.

TWIC: Universal Enrollment Centers

The Jacksonville Universal Enrollment Center is located at: 12400 Yellow Bluff Road, Suite 202, Jacksonville, FL 32226. The office hours are Monday-Friday: 08:00 AM –1:00PM / 1:30PM-4:00 PM, Note: There is no semi-trailer parking available at this Enrollment Center. For general information you can call the TWIC Call Center at 1-855-347-8371, Monday-Friday, 8 a.m. to 10 p.m. Eastern Time.

JAXPORT Business Purpose Credential

In addition to the TWIC, JAXPORT requires a JAXPORT Business Purpose Credential to be issued and registered at JAXPORT’s Access Control Center located at the 9620 Dave Rawls Blvd. Jacksonville Fl. 32226 (Brick Building next to the Main Gate concourse). Hours of operation are Monday-Friday 7:30AM-4:30PM. The JAXPORT Business Purpose Credential is issued at no cost but expires at the end of the contract provisions.

The JAXPORT prime contractor is responsible for sponsoring all sub-contractors for the JAXPORT Business Purpose Credential.

Federal Training Requirement: (33CFR 105.215) Maritime Security Awareness Training

JAXPORT is a federally regulated facility under the Maritime Transportation Security Act of 2002 (MTSA) as codified under the US Code of Federal Regulation 33 CFR Chapter 1, Subchapter H Part 105.

33 CFR 105.215-Security training for all other facility personnel. All other facility personnel, including contractors, whether part-time, full-time, temporary, or permanent, must have knowledge of Maritime security measures and relevant aspects of the TWIC program, through training or equivalent job experience.

To meet the requirements of 33 CFR 105.215; the Prime Contractor/Sub-Contractor employees and all support personnel: Engineers, Suppliers, Truck Drivers, Laborers, Delivery persons etc. (NO EXCEPTIONS) are required to attend JAXPORT's Maritime Security Training given every Wednesday (10am, 2pm & 5pm) at JAXPORT's Access Control Building. Contact the JAXPORT Access Control Center to arrange for the training. JAXPORT will work with Contractors to conduct timely Maritime Security Training classes for larger groups.

All Prime Contractor/Sub-Contractor employees working on the job site for JAXPORT are required to attend JAXPORT's 33 CFR 105.215 (Security/Safety Training for All Other Facility Personnel) class at a cost of \$35.00 per person. Arrangements can be made by calling JAXPORT Access Control Phone# (904) 357-3344.

TWIC Escort Provisions

To ensure contractors can begin work after they receive a Notice to Proceed, JAXPORT will allow prime contractors to have dedicated employee TWIC Escort(s) to handle those contractor employees who have not yet received their TWIC. Escorted employees must have a TWIC receipt validated by Access Control to receive a temporary JAXPORT Business Purpose credential.

Contractor deliveries from Non-TWIC vendors may be escorted by JAXPORT approved Prime Contractor escorts. The prime contractor will be required to submit a request for TWIC Escort privileges to accesscontrol@jaxport.com . Once approved, the contractor's employee(s) will attend a

JAXPORT provided MTSA TWIC Escort Class in addition to the standard MTSA 33 CFR 105.215 Security Class at a combined cost of \$55.00. **These authorized individual(s) must have no collateral duties that will separate the escort from the escorted visitor while serving as escort.**

Note - Limitations to the number of TWIC Escort authorizations will be set by the JAXPORT Public Safety Department.

Truck drivers, vendors, labor may not conduct escorts.

A Contractor authorized by JAXPORT to conduct an escort of a non-TWIC holder in a restricted area must have:

- Successfully completed MTSA 33 CFR 105.215 Security/ Escort Class at \$55.00
- Have a valid TWIC on their person
- Have an approved JAXPORT TWIC ESCORT credential on their person
- Have a tamper-resistant laminated government issued photo identification card on their person.

TWIC Escorts must complete the JAXPORT TWIC Escort Form daily before getting to the access gate. The form will be kept on file at the JAXPORT Security Operations Center (SOC).

The Prime Contractor assumes full liability for the escorted person(s) while on JAXPORT property. The person under escort must have a continuous side by side escort in a secure-restricted area. Federally (USCG / TSA) imposed fines and or consequential damages resulting from a failed TWIC Escort by the Prime or Sub-contractor will be the responsibility of the JAXPORT Prime Contractor regardless of whether it is a direct employee.

Federal regulation definition: 33.CFR 101.105

Escorting means: ensuring that the escorted individual is continuously accompanied while within a secure area in a manner sufficient to observe whether the escorted individual is engaged in activities other than those for which escorted access was granted. This may be accomplished via having side-by-side companion or monitoring, depending upon where the escorted individual will be granted access. Individuals without TWIC may not enter restricted areas without having an individual who holds a TWIC as a side-by-side companion.

JAXPORT TWIC ESCORTS

JAXPORT may provide TWIC escorts at Tariff rate with advanced notice (Minimum 24 hours).

After review of the Contractors operation; JAXPORT will decide the number of escorts required to meet the federal regulation ratios of TWIC escort per non-TWIC worker. This will be based on operational requirements.

JAXPORT TWIC Escort Tariff Fees are published in JAXPORT's Tariff Schedule. Current rates are \$125.00 first two hours; \$50.00 every hour thereafter.

Examples:

1. \$425.00 for one escort for an 8-hour day (=3 TWIC Credentials)
2. \$2125.00 for one escort for 5 days @ 8-hour days (=17 TWIC Credentials)

NOTE:

- All persons entering JAXPORT under TWIC Escort are required to have a tamper-resistant laminated government issued photo identification card on their person. The Identification Card must meet the USCG MTSA standards of 33 CFR 101.515. (State issued paper temporary drivers licenses are not acceptable identification).
- Any violations of the JAXPORT USCG approved Facility Security Plans will result in a Security Violation Hearing and be subject to temporary or permanent denial of access onto JAXPORT Terminals or ability to TWIC Escort.

Significant Designations on Terminals

- The terms "secure area" and "restricted area" do not mean the same thing. A **secure area** is defined as "the area over which an owner/operator has implemented security measures for access control." A **restricted area** is defined as "the infrastructure or locations identified in an area, vessel or facility security assessment or by the operator that require limited access and a higher degree of security protection."
- Entry through the main gates at Blount Island Terminal (BIT) constitutes entry into a secure area; tenant-controlled properties are designated as restricted areas per their individual FSPs.
- Entry into the main gates at Talleyrand Marine Terminal (TMT) and Mitsui/TraPac (MOL) Terminal constitutes entry into a restricted area.

-
- Entry into the cruise terminal provisions gate, crew gate or terminal doors constitutes entry into a restricted area.

Escorts

Truck drivers, vendors, labor may not conduct escorts. The only exception will be given to the ILA President, Vice President and Business Agent when escorting for purposes other than labor.

Truck Drivers: Truck drivers at the gate with no TWIC and/or no escort into a restricted area, will be turned around and will be assisted by security traffic control to safely park until such time as the escort arrives. Truck drivers are responsible for making contact with their approved escort; JAXPORT security is not responsible for arranging or providing escorts. Escort must assume written custody of the driver. For cargo trucks, escorts may be in a vehicle providing the escort is able to visually observe the escorted at all times. This policy DOES NOT apply to POVs.

Contractors: Contractors without a JAXPORT badge and TWIC to access the port will be under escort as defined in this policy.

Contract Security (performing security duties): Must have a JAXPORT credential and a TWIC badge and may not be escorted.

Hired Escorts: Hired escorts would be commercial companies providing escort services for tenants in restricted areas; they must be sponsored by a tenant and may be vetted and approved with additional training and an administrative fee.

Vendors: Vendors without a TWIC will be turned away unless they have a dedicated & approved TWIC escort.

Visitors: According to Florida State Law, visitors without JAXPORT credentials may only visit five times in a 90-day period; this policy will remain in effect. Visitors should be vetted at least 24-hours in advance and await escort at the gate where they are seeking access. **A person with a TWIC badge, but without a JAXPORT credential will be treated as a “5/90” visitor.**

Vessel Crewmembers: When a vessel visits a JAXPORT terminal, the vessel’s crew commonly needs to work in the immediate vicinity of their vessel (handling lines, taking draft readings, etc.). Some vessel crew may not have a TWIC, or they may not be U.S. Merchant

Mariners. Although the dock, pier, or platform the vessel is moored to, is defined as a restricted area. There is no requirement to escort any of the vessel crewmembers that do not have a TWIC while they work alongside their vessel. **The area of dock directly adjacent to the vessel and extending in shore 18 feet from the vessel shall be designated the Crewmember Confinement Area (CCA).**

Vessel crewmembers may be escorted by approved escorts provided they complete the *TWIC Escort form* and escort under no more than a 1 to 5 ratio (excluding labor, contractors, and vendors). Prior to and upon completion of the escort, they are to contact the JAXPORT SOC at 904.357.3360.

Vessels, in coordination with the calling facility, shall ensure all crewmembers do not access Restricted Areas without approved escort. Any crewmember found outside the Crew Confinement Area (CCA) without a TWIC or approved escort may be considered a security breach under the JAXPORT FSP.

Seamen Center workers, ship's agents, etc. who may pick up crewmembers outside the CCA must have TWIC Escort forms on hand and deliver them to the nearest facility gate once completed.

New Hire Provision: If a new hire moves from a secured to a restricted access area, they require side-by-side escort by a TWIC holder at all times. If an individual is a newly hired vessel or facility employee who has applied for but not yet received a TWIC, the owner/operator may grant the individual accompanied access to secure areas of the vessel or facility. This accompanied access may be granted for a period of up to 30 consecutive calendar days from the date of TWIC enrollment, after notification through Homeport that the individual has passed the name-based check. Accompanied access may be extended for an additional 30 days by the local COTP if TSA has not yet issued the new hire's TWIC.

Company/tenant/operator is responsible for reporting and verifying new hires via Homeport. This provision **may not** be used to grant temporary accompanied access to an individual being hired as a CSO, VSO, or FSO or any individual being hired to perform security as a primary duty.

Rail Access

Rail Access: It is the Coast Guard's position that, due to the unique aspects of railroad operations that can impact security at MTSA facilities, all railroad crew servicing secure areas of a MTSA facility should possess a TWIC. The following applies at:

Talleyrand Marine Terminal: CSX will contact JAXPORT SOC via e-mail in advance of train arrival on BIMT to report crew TWIC status; if a crewmember does not possess a TWIC, JAXPORT contract security will provide escort. At no time will JAXPORT contract security personnel board trains or cross train tracks.

Talleyrand Marine Terminal: All Railroad personnel entering TMT must be in possession of a TWIC.

Any violation of the JAXPORT TWIC rail policy will be treated as a security breach under the JAXPORT FSP.

Additional Comments:

The following standards must be met for escorting in the restricted areas of JAXPORT:

1. Escorts must have in their possession a valid TWIC and a permanent JAXPORT credential.
2. Visitors must have a verified reason to enter the restricted area.
3. Side by side escort requirement must be continual and uninterrupted.
4. The person escorting must be able to immediately contact JAXPORT Security Operations Center at (904.357.3360), as indicated on TWIC Escort Form.
5. JAXPORT Security must be notified if the side by side escort has been compromised or the non TWIC holder engages in unlawful or suspicious activity.
6. Non TWIC holders will not be allowed to occupy a privately-owned vehicle (POV) without a JAXPORT authorized escort.
7. TWIC Escort Form indicates Facility and FSO responsible for the action of the escorted & employees.

TWIC Helpdesk: 1-866-347-8942

V. ELECTRONIC DATA REQUIREMENTS (E-BUILDER)

A. General Requirements:

- a) Contractor must purchase at a minimum one (1) user license (see Section 21. H. for details) from JAXPORT and shall provide at a minimum, the following to its staff:
- i. Computer: Minimum Intel Pentium® 4 Processor 2.4 GHz or equivalent processor with 512MB of RAM; recommended Centrino Duo® Processors 1.6 GHz or equivalent with 2GB of RAM, or higher.
 - ii. Computer Operation System: Windows XP, Windows Vista, or Windows 7
 - iii. Web Browser: Microsoft Internet Explorer 9
 - iv. Work and Spreadsheet Processors: Microsoft Office Word, Excel and Outlook
 - v. Scheduling Software: Microsoft Project or Primavera
 - vi. Internet Service Provider: A reliable ISP in the area of the Project
 - vii. Connection Speed/Minimum Bandwidth: DSL, ADSL or T1 Line for transferring a minimum of 3 Mbps Downstream and 512 Kbps Upstream
- b) Contractor shall provide its management personnel assigned to this Project with access to personal computers and the Internet on a daily basis.

B. Project Web Requirements; Use of e-Builder Enterprise:

This project will utilize a web-based project management tool called e-Builder Enterprise™. This web-based application is a collaboration tool, which will allow all project team members continuous access through the Internet to important project data as well as up to the minute decision and approval status information.

Contractor shall conduct Project controls, outlined by JAXPORT and the Project Manager, utilizing e-Builder Enterprise™. No additional software will be required. Furthermore, the JAXPORT Engineering and Construction department will assist Contractor in providing training of personnel.

Contractor shall have the responsibility for visiting the Project web site on a daily basis, and as necessary to be kept fully apprised of Project developments, for correspondence, assigned tasks and other matters that transpire on the site. These may include but are not limited to: Contracts, Contract Exhibits, Contract Amendments, Drawing Issuances, Addenda, Bulletins, Permits, Insurance & Bonds, Safety Program Procedures, Safety Notices, Accident Reports, Personnel Injury Reports, Schedules, Site Logistics, Progress Reports, Daily Logs, Non-Conformance Notices, Quality Control Notices, Punch Lists, Meeting Minutes, Requests for Information, Submittal Packages, Substitution Requests, Monthly Payment Request Applications, Supplemental Instructions, Construction Variation Directives, Potential Variation Orders, Variation Order Requests, Variation Orders, and the like. All supporting data including but not limited to shop drawings, product data sheets, manufacturer data sheets and instructions, method statements, safety MSDS sheets, Substitution Requests and the like will be submitted in digital format via e-Builder Enterprise™.

C. Electronic File Requirements:

In addition to the standard closeout submittal requirements detailed elsewhere in the Contract Documents, the Contractor shall also submit all closeout documents including all “As-Built Drawings”, catalog cuts and Owner’s Operation and Maintenance manuals in digital format. All documents (including as-built drawings) shall be converted or scanned into the Adobe Acrobat (.PDF) file format and uploaded to e-Builder Enterprise™.

e-Builder Enterprise™ is a comprehensive Project and Program Management system that JAXPORT has implemented for managing documents, communications and costs between the Contractor, Design Consultants and Owner. E-Builder Enterprise™ includes extensive reporting capabilities to facilitate detailed project reporting in a web-based environment that is accessible to all parties and easy to use.

D. Central Document Vault:

e-Builder Enterprise™ system includes a central database that maintains all project information and manages project communications amongst team members.

E. Communication/Correspondence:

e-Builder provides electronic routable communication forms that provide historical tracking, documentation, and increased accountability of project members.

F. Project Calendars:

Meetings will be scheduled and maintained centrally on e-Builder Enterprise™.

G. Reporting:

All of the project and program data including documents, communications and costs are accessible through integrated online reports. These reporting tools are completely configurable by each user. All reports can be exported to Excel for added flexibility.

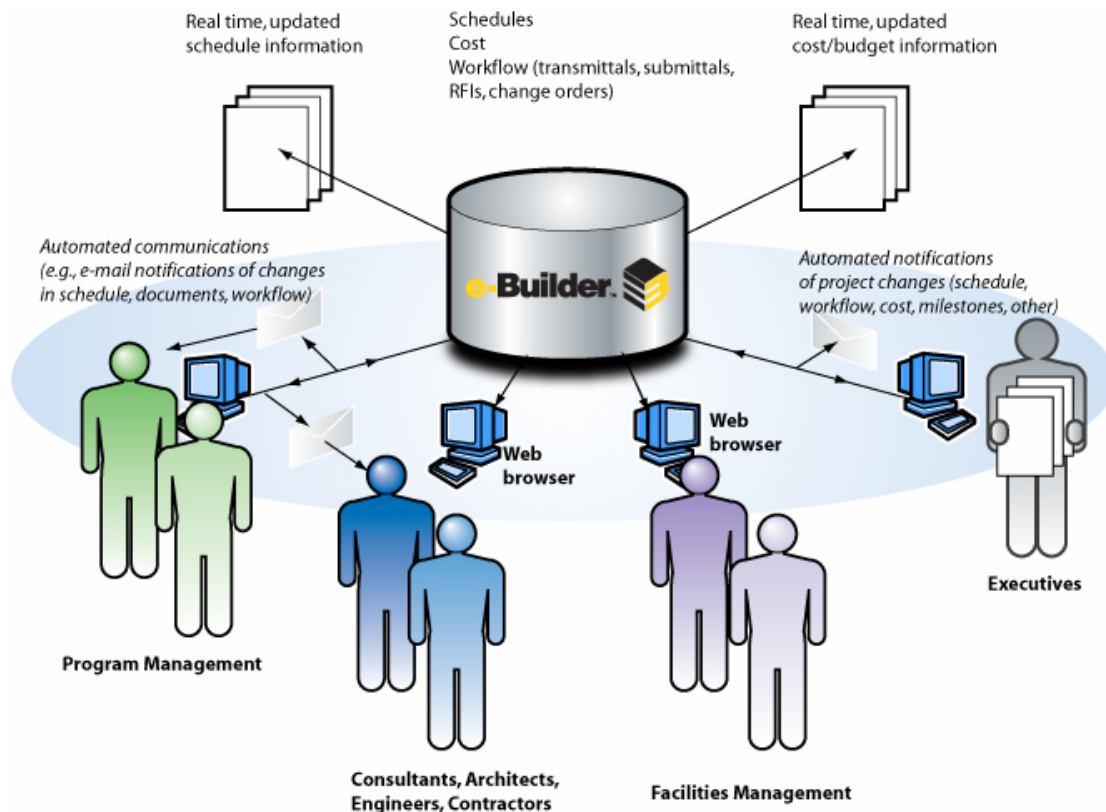

E-BUILDER LICENSING REQUIREMENTS

H. E-Builder Enterprise™ User Licenses:

Each user license includes full access to e-Builder Enterprise™ including all of the documents and reports mentioned above. Furthermore, each user license provides the e-Builder software as a service (SaS) including:

-
- All hosting, operation, maintenance and data backup of the e-Builder Enterprise™ software and documents which are maintained in state-of-the-art data centers located throughout the United States.
 - Quarterly e-Builder Enterprise™ software enhancements
 - Unlimited phone, email and web-based support 24-hours:

The cost for licenses that the Contractor will need to acquire will be \$1,495.00 per user/per year or \$124.58 per month as part of their General Conditions fee and shall remain in effect for the duration of the project. For example, if the contract is for 6 months, then the Contractor should be prepared to pay license fees for 8 months, allowing up to sixty (60) calendar days for close out.

The payment must be in the form of a check; payable to JAXPORT for the number of licenses needed by the Contractor and will be collected at the Pre-Construction meeting and/or prior to the Notice-to-Proceed.

Additional licenses can be obtained at any time during the project, by contacting JAXPORT'S Project Manager.

(THE REMINDER OF THIS PAGE IS BLANK INTENTIONALLY)

W. ADDENDA ACKNOWLEDGEMENT / SIGNATURE PAGE

Acknowledgement of the following addenda is hereby made:

Addendum No 1: _____ Date: _____ Proposer's Initials: _____
Addendum No 2: _____ Date: _____ Proposer's Initials: _____
Addendum No 3: _____ Date: _____ Proposer's Initials: _____

I hereby acknowledge, as Proposer's authorized agent that I have fully read and understand all terms and conditions as set forth in this RFP and will fully comply with such terms and conditions.

Date: _____

Company Name: _____

Authorized Agent's Name: _____

Title: _____

Authorized Agent's Email Address: _____

Vendor is a (check one) : _____ Corporation _____ Partnership _____ Individual

Federal Identification Number : _____

Remittance Address: _____

Telephone Number: _____ Fax Number: _____

EXHIBIT "A"

CONFLICT OF INTEREST CERTIFICATE

Proposer must execute either Section I or Sections II and III, hereunder, as required by Chapter 112 of the Florida Statutes. Failure to execute either Section I or Section II and Section III may result in the rejection of this bid / proposal.

SECTION I

I hereby certify that no public officer or employee of the Jacksonville Port Authority (JAXPORT) has a material financial interest or any business entity of which the officer, director or employee of the officer's, director's or employee's spouse or child is an officer, partner, director, or proprietor or in which such officer, director or employee or the official's, director's or employee's spouse or child, or any combination of them, has a material interest in this contract.

"Material Interest" means direct or indirect ownership of more than 10 percent of the total assets or capital stock of any business entity.

Signature

Company Name

Name of Official (type or print)

Business Address

City, State, Zip Code

Date

EXHIBIT "A"

CONFLICT OF INTEREST CERTIFICATE

SECTION II

I hereby certify that the following named public official(s) and/or JAXPORT employee(s) having material financial interest(s) (in excess of 10%) in this company have each filed Section III (Public Official Disclosure) with the Jacksonville Port Authority, Office of the Chief Executive Officer, 2831 Talleyrand Avenue, Jacksonville, Florida 32206-0005 prior to the time of bid opening.

Name	Title or Position	Date of Public Official Disclosure Filing

Signature

Company Name

Name of Official (type or print)

Business Address

City, State, Zip Code

Date

EXHIBIT "A"

CONFLICT OF INTEREST CERTIFICATE

SECTION III (PUBLIC OFFICIAL DISCLOSURE)

JAXPORT requires that a public official who has a financial interest in a proposal or contract make a disclosure at the time that the proposal or contract is submitted or at the time that the public official acquires a financial interest in the proposal or contract. Please provide disclosure, if applicable, with proposal.

Public Official Signature: _____

Public Official Name: _____

Public Position Held: _____

Position or Relationship with Proposer: _____

Date: _____

EXHIBIT B

SWORN STATEMENT PURSUANT TO SECTION 287.133(3)(A), FLORIDA STATUTES, ON PUBLIC ENTITY CRIMES

THIS FORM MUST BE SIGNED AND SWORN TO IN THE PRESENCE OF A NOTARY PUBLIC OR OTHER OFFICIAL AUTHORIZED TO ADMINISTER OATHS.

1. This sworn statement is submitted to _____
(print name of the public entity)
- by _____
(print individual's name and title)
- for _____
(print name of entity submitting sworn statement)

whose business address is _____

and (if applicable) its Federal Employer Identification Number (FEIN) is _____

(If the entity has no FEIN, include the Social Security Number of the individual signing

this sworn statement: _____.)

2. I understand that a “public entity crime” as defined in Paragraph 287.133(1)(g), **Florida Statutes**, means a violation of any state or federal law by a person with respect to and directly related to the transaction of business with any public entity or with an agency or political subdivision of any other state or of the United States, including, but not limited to, any bid or contract for goods or services to be provided to any public entity or an agency or political subdivision of any other state or of the United States and involving antitrust, fraud, theft, bribery, collusion, racketeering, conspiracy, or material misrepresentation.
3. I understand that “convicted” or “conviction” as defined in Paragraph 287.133(1)(b), **Florida Statutes**, means a finding of guilt or a conviction of a public entity crime, with or without an adjudication of guilt, in any federal or state trial court of record relating to charges brought by indictment or information after July 1, 1989, as a result of a jury verdict, nonjury trial, or entry of a plea of guilty or nolo contendere.
4. I understand that an “affiliate” as defined in Paragraph 287.133(1)(a), **Florida Statutes**, means:
1. A predecessor or successor of a person convicted of a public entity crime; or
 2. An entity under the control of any natural person who is active in the management of the entity and who has been convicted of a public entity crime. The term “affiliate” includes those officers, directors, executives, partners, shareholders, employees, members, and agents who are active in the interest in another person, or a pooling of equipment or income among persons when not for fair market value under an arm’s length agreement, shall be a prima facie case that one person controls another person. A person who knowingly enters into a joint venture with a person who has been convicted of a public entity crime in Florida during the preceding 36 months shall be considered an affiliate.
5. I understand that a “person” as defined in Paragraph 287.133(1)(e), **Florida Statutes**, means any natural person or entity organized under the laws of any state or of the United States with the legal power to enter into a binding contract and which bids or applies to bid on contracts for the provision of goods or services let by a public entity, or which otherwise transacts or applies to transact business with a public entity. The term

“person” includes those officers, directors, executives, partners, shareholders, employees, members, and agents who are active in management of an entity.

6. Based on information and belief, the statement which I have marked below is true in relation to the entity submitting this sworn statement. **(Indicate which statement applies.)**

_____ Neither the entity submitting this sworn statement, nor any of its officers, directors, executives, partners, shareholders, employees, members, or agents who are active in the management of the entity, nor any affiliate of the entity has been charged with and convicted of a public entity crime subsequent of July 1, 1989.

_____ The entity submitting this sworn statement, or one or more of its officers, directors, executives, partners, shareholders, employees, members, or agents who are active in the management of the entity, or an affiliate of the entity has been charged with and convicted of a public entity crime subsequent to July 1, 1989.

_____ The entity submitting this sworn statement, or one or more of its officers, directors, executives, partners, shareholders, employees, members, or agents who are active in the management of the entity, or an affiliate of the entity has been charged with and convicted of a public entity crime subsequent to July 1, 1989. However, there has been a subsequent proceeding before a Hearing Officer of the State of Florida, Division of Administrative Hearings and the Final Order entered by the Hearing Officer determined that it was not in the public interest to place the entity submitting this sworn statement on the convicted vendor list. **(Attach a copy of the final order)**

I UNDERSTAND THAT THE SUBMISSION OF THIS FORM TO THE CONTRACTING OFFICER FOR THE PUBLIC ENTITY IDENTIFIED IN PARAGRAPH 1 (ONE) ABOVE IS FOR THAT PUBLIC ENTITY ONLY AND, THAT THIS FORM IS VALID THROUGH DECEMBER 31 OF THE CALENDAR YEAR IN WHICH IT IS FILED. I ALSO UNDERSTAND THAT I AM REQUIRED TO INFORM THE PUBLIC ENTITY PRIOR TO ENTERING INTO A CONTRACT IN EXCESS OF THE THRESHOLD AMOUNT PROVIDED IN SECTION 287.017, FLORIDA STATUTES FOR CATEGORY TWO OF ANY CHANGE IN THE INFORMATION CONTAINED IN THIS FORM.

(signature)

(date)

STATE OF _____

COUNTY OF _____

PERSONALLY APPEARED BEFORE ME, the undersigned authority,

_____ who, after first being sworn by me, affixed
(name of individual signing)

his/her signature in the space provided above on this _____ day of _____, 20_____.

NOTARY PUBLIC

My commission expires:

EXHIBIT C

ACKNOWLEDGEMENT AND ACCEPTANCE OF E-VERIFY COMPLIANCE

E-VERIFY PROGRAM FOR EMPLOYMENT VERIFICATION

In accordance with the Governor of Florida, Executive Order Number 11-02 (Verification of Employment Status), whereas, Federal law requires employers to employ only individuals eligible to work in the United States; and whereas, the Department of Homeland Security's E-Verify system allows employers to quickly verify in an efficient and cost effective manner;

The Contractor agrees to utilize the U.S. Department of Homeland Security's E-Verify system to verify the employment eligibility of all new employees hired by the Contractor during the term of the contract. Contractors must include in all subcontracts the requirement that all subcontractors performing work or providing goods and services utilize the E-Verify system to verify the employment eligibility of all new employees hired by the subcontractor during the contract term. The Contractor further agrees to maintain records of its participation and compliance and its subcontractor's participation and compliance with the provisions of the E-Verify program, and to make such records available to JAXPORT upon request. Failure to comply with this requirement will be considered a material breach of the contract.

By signing below, I acknowledge that I have reviewed, accept and will comply with the regulations pertaining to the E-Verify program.

Company Name

Name of Official (Please Print)

Signature of Principal

Title

Date

EXHIBIT "D"
CONTRACTOR CERTIFICATION REGARDING
SCRUTINIZED COMPANIES LISTS

Respondent Contractor Name: _____
Contractor FEIN: _____
Contractor's Authorized Representative Name and Title: _____
Address: _____
City: _____ State: _____ Zip: _____
Phone Number: _____
Email Address: _____

Section 287.135 of the Florida Statutes prohibits agencies from contracting with a company on the Scrutinized Companies with Activities in Sudan List or on the Scrutinized Companies with Activities in the Iran Petroleum Energy Sector List, lists created pursuant to section 215.473, Florida Statutes, for goods or services over \$1,000,000.

As the person authorized to sign on behalf of Respondent, I hereby certify that this company, listed above by "Respondent Contractor Name," complies fully with the law and is not listed on either the Scrutinized Companies with Activities in Sudan List or the Scrutinized Companies with Activities in the Iran Petroleum Energy Sector List. I understand that pursuant to section 287.135, Florida Statutes, the submission of a false certification may subject the company to civil penalties, attorney's fees, and/or costs.

So Certified:
Authorized Representative's Signature _____
Date Signed: _____

EXHIBIT E

ARTICLE V

JAXPORT PROCUREMENT GOALS SMALL AND EMERGING BUSINESS (SEB) PARTICIPATION POLICY, GOALS, CONDITIONS AND INSTRUCTIONS

5.01 POLICY

It is the official policy of the Jacksonville Port Authority (JAXPORT) to require the inclusion of firms owned and controlled by Small and Emerging Business Enterprises in contract awards and projects whenever feasible.

The Authority has determined that the participation for this project will be 100% SEB (JSEB/DBE/SBA/MBE/WBE) for this contract. This bid has been designated *only* for the competitions of vendors in any of the categories listed below:

5.02 CERTIFICATION

Jacksonville Small and Emerging Business Enterprise (JSEB): JSEB vendors must be COJ certified and included in the Directory prior to the date of the bid opening or have a pending application that is resolved prior to award.

Disadvantaged Business Enterprise (DBE): DBE means a small business concern which is at least 51 percent owned by one or more socially and economically disadvantaged individuals and whose management and daily business operations are controlled by one or more of the socially and economically disadvantaged individuals that own the business. Firms desiring to participate as DBEs in this bid must be duly certified by the Florida Department of Transportation (FDOT) or a member of the Florida Unified Certification Program (FUCP) and listed in the FUCP DBE Directory of certified firms. JTA is the local certifying agency for the DBE Program.

Small Business Administration Certified Firms (SBA): Small Business companies as designated by the U.S Small Business Administration and listed in the Central Contractor Registration (CCR) on-line database. Firms must be active with assigned DUNS numbers.

Minority/Women Business Enterprise (MBE/WBE): A for-profit small business concern that performs a commercially useful function and is legitimately owned and controlled by minorities or women (as described by the Minority Business Development Agency of the Department of Commerce).

5.03 SEB Agencies

**City of Jacksonville
Ed Ball Building
214 North Hogan Street, Suite 800
Jacksonville, Florida 32202
Phone: (904) 255-8840
Fax: (904) 255-8842
<http://cojapps.coj.net/jseb/>**

**Jacksonville Transportation Authority
Disadvantaged Business Enterprise Program
100 N. Myrtle Avenue
Jacksonville, Florida 32203
(904) 598-8728
www.jtafla.com**

Florida Department of Transportation (FDOT)
Equal Opportunity Office
605 Suwannee Street MS-65
Tallahassee, Florida 32399
(850) 414-4747
<http://www.fdot.gov/equalopportunity/>

US Small Business Administration
North Florida District Office
7825 Baymeadows Way, Suite 100-B
Jacksonville, Florida 32256
(904)443-1930
http://web.sba.gov/pro-net/search/dsp_dsbs.cfm

Minority Business Development Agency
Miami District Office
51 Southwest, 1st Avenue
Miami, Florida 33130
(786) 315-0888
www.mbda.gov

5:04 SEB Certified Vendor Obligation

Bidders are required to submit a proof of current certification with the respective agencies at the time of bid opening. Vendors who do not meet this requirement will be considered non-responsive and ineligible for award. In addition, submission of a bid by a prospective bidder shall constitute full acceptance of all conditions outlined in this bid specification. Please note that in order to maintain the integrity of its SEB Program JAXPORT is requiring that the successful Bidder performs at least 50 percent (50%) of the total value of the work, failure to do so will constitute a breach of contract.

5:05 SEB – FORM 1

Prospective bidders who wish to utilize other Small and Emerging vendors on this contract should complete and submit SEB Form 1 with their bids. Please see attached form.

For further information concerning participation on this bid, please contact:

Brian Williams, Coordinator
JAXPORT SEB Program
2831 Talleyrand Avenue
Jacksonville, Florida 32206
Office Number: (904) 357-3003
Fax Number: (904) 357-3077
Brian.Williams@jaxport.com

JACKSONVILLE PORT AUTHORITY "Schedule of Subcontractor / Subconsultant Participation"

Name of Bidder: _____

Project Title: _____

BID Number: _____

TOTAL BASED BID AMOUNT: _____

****Please list all SEB Vendors first**

NAME SUB FIRM	ADDRESS OF FIRM	TYPE SUB (SEB)	TYPE OF WORK TO BE PERFORMED	TOTAL CONTRACT VALUE & \$\$ PERCENTAGE
_____	_____	_____	_____	_____
_____	_____	_____	_____	_____
_____	_____	_____	_____	_____
_____	_____	_____	_____	_____
_____	_____	_____	_____	_____
_____	_____	_____	_____	_____
_____	_____	_____	_____	_____
_____	_____	_____	_____	_____
_____	_____	_____	_____	_____
_____	_____	_____	_____	_____

CONSULTANT/SUBCONTRACTOR/SUPPLIER TOTAL VALUES		
Hispanic, Asian-American Participation Total Values:	\$ _____	_____ % of contract
African-American Participation Total Value:	\$ _____	_____ % of contract
Native-American Participation Total Value:	\$ _____	_____ % of contract
Woman Participation Total Value:	\$ _____	_____ % of contract
Other Socially and Economically Disadvantaged Individual Including JSEB/MBE/WBE/DBE/SBA Vendors	\$ _____	_____ % of contract

The undersigned will enter into a formal Agreement with the JSEB/DBE Suppliers/Consultants/Subcontractors identified herein for work listed in this scheduled conditioned upon execution of a contract with JAXPORT. Under penalties of perjury I declare that I have read the foregoing conditions and instructions and the facts are true to the best of my knowledge and beliefs.

Signature: _____ Title: _____ Date: _____

Print Name: _____

Sworn to and subscribed before me, this _____ day of _____, 20____

NOTARY PUBLIC STATE OF: _____

MY COMMISSION EXPIRES: _____

PRINTED, TYPED OR STAMPED
COMMISSIONED NAME OF NOTARY PUBLIC

JACKSONVILLE PORT AUTHORITY
CERTIFIED SEBPARTICIPANT
"IDENTIFICATION AFFIDAVIT"

STATE OF _____ COUNTY OF _____

I hereby declare and affirm that I am the _____
(Title: Owner, President, etc.)

And duly authorized representative of _____
(Name of Firm)

Whose address is _____

I hereby declare and affirm that **I am a CERTIFIED SEB** as defined by the contract documents for this Proposal # _____, and that I will provide information to document this fact. This firm is interested in quoting/bidding on the following work being procured by the JAXPORT under this proposal.

Specify whether participation is as a SubContractor, Supplier, Manufacturer or Service

Specify % of Contract SEB firm will receive: _____%

Specify Quote or Bid Amount: \$ _____

I DO SOLEMNLY DECLARE AND AFFIRM UNDER THE PENALTIES OF PERJURY THAT THE CONTENTS OF THE FOREGOING DOCUMENT ARE TRUE AND CORRECT, AND THAT I AM AUTHORIZED ON BEHALF OF THE FIRM TO MAKE THIS AFFIDAVIT.

(Date) _____ (Affiant) _____

Sworn to and subscribed before me this _____ day of _____, 20____.

Personally known _____

OR produced identification _____ Notary Public-State of _____

(Type of identification) My commission expires _____

(Printed, typed or stamped
Commissioned name of Notary Public)

The Contractor must submit (1) one form completely filled out for each individual SEB participant.

JACKSONVILLE PORT AUTHORITY
“LETTER OF INTENT TO PERFORM”

TO: _____
(Name of General Contractor / Proposer)

JAXPORT PROJECT TITLE: _____ NO.: _____

The undersigned intends to perform work in connection with the above Project as (Check one):

_____ An individual _____ a corporation
_____ A partnership _____ a joint-venture

SEB GROUP STATUS:

_____ African American _____ Hispanic, Asian, or Native American
_____ Women Business Owner _____ Other socially disadvantaged individual
Including JSEB

I, undersigned, understand that the price below is a representative of my intent to perform the scope of work stated below. I further understand that this price is subject to increase or decrease due to the status of the undersigned is confirmed on the attached SEB Contractor Identification Affidavit.

Specify in detail, work items or parts thereof to be performed:

At the following price; \$ _____
_____ % of the total dollar value of this subcontract will be sublet and or awarded to non-minority SubContractors.

The undersigned agrees to enter into a contract with you to perform as a SubContractor on work for which you have been awarded.

(Date) (Telephone) (Name of **Certified** SEB SubContractor)

(Firm Address) By: _____
(Signature)

(City and State) Name: _____
(Typed)

Title: _____

The Contractor must submit (1) one form completely filled out for each individual SEB participant.

JACKSONVILLE PORT AUTHORITY
CERTIFIED SEB"UNAVAILABILITY" CERTIFICATION

I, _____, _____
 (Name) (Title)

of _____, certify that on the dates below, I invited the following **CERTIFIED** DBE/WJE(s) to propose work items to be performed on JAXPORT Proposal.

Date of Request (Y/N)	Name of CERTIFIED JSEB/MBE/WBE/DBE/SBA(s) Firm	Response
_____	_____	_____
_____	_____	_____
_____	_____	_____
_____	_____	_____

The following submitted proposals that were not acceptable:

Name of CERTIFIED JSEB/MBE/WBE/DBE/SBA(s)	Reason for Unacceptability
_____	_____
_____	_____
_____	_____

Date: _____ By: _____
 (Signature)

Sworn to and subscribed before me this _____ day of _____, 20____.

Personally known _____

OR produced identification _____ Notary Public-State of _____

_____ My commission expires _____
 (Type of identification)

 (Printed, typed or stamped commissioned name of Notary Public)

JACKSONVILLE PORT AUTHORITY CONTRACTOR'S "MONTHLY REPORT"

PRIME CONTRACTOR NAME: _____ PROJECT TITLE: _____

PROFESSIONAL SERVICES NO.: _____ - OR - BID NO: _____

CURRENT CONTRACT TOTAL AMOUNT \$ _____ CONTRACT NO. : _____

INVOICE INFORMATION	
INVOICE NO.: _____	CURRENT INVOICE \$: _____
FOR PERIOD ENDING DATE: _____	CUMULATIVE INVOICED \$: _____
CONTRACT % COMPLETE: _____	

CONTRACT GOAL TRACKING	
SEBGOAL \$: _____	SEBGOAL % : _____
<i>PRIOR MONTH</i>	
CUMULATIVE JSEB/MBE/WBE/DBE/SBA\$: _____	
<i>PRIOR MONTH</i>	
CUMULATIVE NON- JSEB/MBE/WBE/DBE/SBA\$: _____	<i>FORMULA FOR CURRENT MONTH %:</i> CUMULATIVE \$ / CUMULATIVE \$ INVOICED
CUMULATIVE JSEB/MBE/WBE/DBE/SBA\$: _____	CUMULATIVE JSEB/MBE/WBE/DBE/SBA% : _____
CUMULATIVE NON- JSEB/MBE/WBE/DBE/SBA\$: _____	CUMULATIVE NON- JSEB/MBE/WBE/DBE/SBA% : _____

SEBSUBCONTRACTORS TO BE PAID FROM THIS INVOICE					
COMPANY NAME	FEDERAL I.D. NO.	ZIP CODE	JSEB/MBE/WBE/DBE/SBATYPER ¹	TYPE OF WORK ²	\$ THIS PAYMENT
TOTAL					

¹ SEB TYPES:

AA: African American; **WBE:** Woman; **HANA:** Hispanic, Asian, Native American; **OTHER:** Economically or Socially;

²TYPE OF WORK: Examples: Catering, Clerical, Consulting, Engineering, Hauling, Janitorial, Masonry, Site Clearing, Technical Support

Notes:

1. THIS MONTHLY FORM MUST BE COMPLETED AND SUBMITTED WITH ALL REQUESTS FOR PAYMENT AND FINAL PAYMENT.
2. Contractor shall attach to this form a typewritten explanation of any differences in SEB participation from original contract commitment.

The undersigned hereby affirms and declares that the above listed firm(s) were actually employed in the performance of work services under this contract, and further that each such firm earned and has been paid the stated amounts for their respective efforts.

Sworn to and subscribed before me on this _____ day of _____ 20__

Signature _____
Name (printed): _____

Notary Public

EXHIBIT F
ELECTRONIC DATA REQUIREMENTS (E-BUILDER)

Exhibit _____ **JAXPORT CONTRACT NO.: C-1752**

Contractor agrees to the following:

"The E-Builder system is for authorized users only. Unauthorized use of this system is strictly prohibited and may be subject to criminal prosecution. Use of this network constitutes consent to monitoring retrieval and disclosure of any information stored within the system for any purpose including criminal prosecution. Information contained within this system is confidential, intended for the licensed users and may contain information that is proprietary to the user, and/or privileged, confidential and/or otherwise exempt from disclosure under applicable state and federal law. Use by anyone other than the licensed users is not a waiver of any applicable privilege."

_____ Signature	_____ Company Name
_____ Name of Official (type or print)	_____ Business Address
_____ City and State	_____ Zip Code

PRICE PROPOSAL FORM
JAXPORT PROJECT NO.: T2021.07
JAXPORT CONTRACT NO.: C-1752
DESIGN-BUILD TERMINAL FACILITIES BUILDINGS
TALLEYRAND MARINE TERMINAL

BIDDER'S NAME: _____

The undersigned hereby proposes to furnish all materials, equipment, labor, and supervision for the above identified project, in accordance with the specifications and drawings for Contract No. **C-1752**, at the following price:

Scope of Work: Furnish all labor, material, equipment, incidentals, subcontracts, and supervision necessary or manifestly required to design, permit, furnish, and construct pre-engineered metal buildings (PEMB) as specified in the attached Section 13 34 19 Metal Building Systems at JAXPORT's Talleyrand Marine Terminal, as shown in the project drawings.

BASE BID LUMP SUM WORK		
Item #	Description	Total Item Amount
1	Mobilization / Demobilization (Total limited to not more than 6% of Item #3)	\$
2	General Requirements	\$
3	Design & Construct Storage Building	\$
A. SUM OF ALL LUMP SUM WORK		\$

OWNER'S OPTION 1		
Item #	Description	Total Item Amount
1	Design & Construct Equipment Building	\$
B. SUM OF OWNER'S OPTION 1 WORK		\$

BID SUMMARY				
BASE BID SUMMARY				
	C. Total Lump Sum Work (Line A)	\$		
	D. Total Owner's Option 1 (Line B)	\$		
E. TOTAL BID AMOUNT (LINES C + D)				\$
Notes				
1. Bids will be evaluated based on Line E above.				

(Submission of more than one bid form for the same work by an individual, firm,

PRICE PROPOSAL FORM
JAXPORT PROJECT NO.: T2021.07
JAXPORT CONTRACT NO.: C-1752
DESIGN-BUILD TERMINAL FACILITIES BUILDINGS
TALLEYRAND MARINE TERMINAL

partnership or corporation under the same or different names and/or any alterations, exceptions or comments contained within the bid form shall be grounds for rejection of the bid)

Basis of Award: The Authority reserves the right to award this contract to the bidder whose prices is the lowest based on the Total Base Bid Items and Owner's Option 1, subject to the availability of appropriated funds.

The Authority reserves the right to award this contract to the lowest, responsive, responsible bidder, and whose bid is fully conforming to the requirements of the bid documents. Nevertheless, JAXPORT (JAXPORT) reserves the right to waive informalities in any bid, to reject any or all bids, and to accept the bid which in its judgment will be in the best interest of JAXPORT. JAXPORT will be the sole judge of which proposal will be in its best interest and its decision will be final.

JAXPORT reserves the right to award this contract to the bidder offering the lowest price consistent with meeting all specifications, terms, conditions, delivery requirements set forth on this bid. No award will be made until all necessary inquiries have been made into the responsibility of the lowest conforming bidder and JAXPORT is satisfied that the lowest bidder met all the requirements, is qualified and has the necessary organization, capital and resources required to perform the work under the terms and conditions of the contract. JAXPORT reserves the right to accept or reject any or all proposals, in whole or in part.

The required bid guaranty is attached hereto (see "Supplemental Instructions to Bidders") of the contract documents.

Acknowledgment of the following addenda is hereby made (see "Supplemental Instructions to Bidders"):

Addendum No. 1, Dated: _____ Initials: _____
Addendum No. 2, Dated: _____ Initials: _____
Addendum No. 3, Dated: _____ Initials: _____
Addendum No. 4, Dated: _____ Initials: _____

See also "Bid Contents and Format" section of the "Supplemental Instructions to Bidders".

PRICE PROPOSAL FORM
JAXPORT PROJECT NO.: T2021.07
JAXPORT CONTRACT NO.: C-1752
DESIGN-BUILD TERMINAL FACILITIES BUILDINGS
TALLEYRAND MARINE TERMINAL

Name of Contractor

AUTHENTICATION (see "Supplemental Instructions to Bidders")

Firm

Business Address

City

State

Zip Code

Mailing Address, if different from above

Authorized Signature

Date Executed

Typed Name

Title

Telephone Number

Facsimile Number

Company Federal Tax I.D. No.

Company's Business License No.

BID BOND FORM
JAXPORT PROJECT NO.: T2021.07
JAXPORT CONTRACT NO.: C-1752
DESIGN-BUILD TERMINAL FACILITIES BUILDINGS
TALLEYRAND MARINE TERMINAL

KNOW ALL MEN BY THESE PRESENTS, that we, the undersigned,
_____ as
Principal and _____ as Surety,
are hereby held and firmly bound unto JAXPORT, in the sum of
_____ dollars (\$_____) as liquidated damages for payment
of which, well and truly to be made, we hereby jointly and severally bind ourselves, our
heirs, executors, administrators, successors and assigns.

The Conditions of the above obligation are such that whereas the Principal has
submitted to JAXPORT, a certain Proposal attached hereto and hereby made part
hereof, to enter into a Contract Agreement in writing, for construction of
_____.

NOW THEREFORE,

- (a) If said Proposal shall be rejected or withdrawn as provided in the
Instructions to Bidders attached hereto or, in the alternative,

- (b) If said Proposal shall be accepted and the Principal shall sign and deliver a
formal contract document in the form of the Contract Agreement attached
hereto (properly completed in accordance with said Proposal) and shall
furnish the specified Bonds required by Section V of the Contract
Documents in the amount equal to one hundred percent (100%) of the
base bid within ten (10) consecutive days after the receipt of said
contract,

thence this obligation shall be void, otherwise, it shall remain in force and effect; it
being expressly understood and agreed that the liability of the Surety for any and all
claims hereunder in no event shall exceed the amount of this obligation as herein
stated.

The Surety, for value received, hereby stipulates and agrees that the obligations
of said Surety and its bond shall be in no way impaired or affected by an extension of

BID BOND FORM
JAXPORT PROJECT NO.: T2021.07
JAXPORT CONTRACT NO.: C-1752
DESIGN-BUILD TERMINAL FACILITIES BUILDINGS
TALLEYRAND MARINE TERMINAL

the time within which such Proposal may be accepted, and said Surety does hereby waive notice of any extension.

The sum herein stated shall be due and payable to JAXPORT, and the "Surety" herein agrees to pay said sum immediately upon demand of said JAXPORT in good and lawful money of United States of America; as liquidated damages for failure thereof of said "Principal".

IN WITNESS WHEREOF, the said _____,
As "Principal" herein, has caused these presents to be signed in its name by its _____ and attested by its _____ under its corporate seal, and the said _____ as "Surety" herein, has caused these presents to be signed in its name by its _____ and attested by its _____ under its corporate seal, this _____
Day of _____ A.D., 20____.

AS PRINCIPAL (SEAL)

ATTEST:

Its _____

**Signed, Sealed and Delivered
In the presence of:**

Its _____

By _____
AS SURETY

JACKSONVILLE PORT AUTHORITY
“Schedule of SubContractor/Sub-Contractor Participation”

Name of Bidder: _____

Project Title: _____

BID Number: _____

TOTAL BASED BID AMOUNT: _____

****Please list all JSEB/MBE/WBE/DBE/SBA's first**

NAME SUB FIRM CONTRACT PERCENTAGE	ADDRESS OF FIRM	TYPE SUB (JSEB/MBE/WBE/DBE/SBA)	TYPE OF WORK TO BE PERFORMED	TOTAL VALUE & \$\$
_____	_____	_____	_____	_____
_____	_____	_____	_____	_____
_____	_____	_____	_____	_____
_____	_____	_____	_____	_____
_____	_____	_____	_____	_____
_____	_____	_____	_____	_____
_____	_____	_____	_____	_____
_____	_____	_____	_____	_____
_____	_____	_____	_____	_____
_____	_____	_____	_____	_____
_____	_____	_____	_____	_____
_____	_____	_____	_____	_____
_____	_____	_____	_____	_____
_____	_____	_____	_____	_____
_____	_____	_____	_____	_____
_____	_____	_____	_____	_____
_____	_____	_____	_____	_____
_____	_____	_____	_____	_____
_____	_____	_____	_____	_____
_____	_____	_____	_____	_____
_____	_____	_____	_____	_____
_____	_____	_____	_____	_____
_____	_____	_____	_____	_____

CONTRACTOR/SUBCONTRACTOR/SUPPLIER TOTAL VALUES		
Hispanic, Asian-American Participation Total Values:	\$ _____	% of contract
African-American Participation Total Value:	\$ _____	% of contract
Native-American Participation Total Value:	\$ _____	% of contract
Woman Participation Total Value:	\$ _____	% of contract
Other Socially and Economically Disadvantaged Individual Including JSEB	\$ _____	% of contract

The undersigned will enter into a formal Agreement with the SEB Suppliers/Contractors/SubContractors identified herein for work listed in this scheduled conditioned upon execution of a contract with JAXPORT. Under penalties of perjury I declare that I have read the foregoing conditions and instructions and the facts are true to the best of my knowledge and beliefs.

Signature: _____ Title: _____ Date: _____

Print Name: _____

Sworn to and subscribed before me, this _____ day of _____, 20 _____

NOTARY PUBLIC STATE OF: _____

MY COMMISSION EXPIRES: _____

 PRINTED, TYPED OR STAMPED
 COMMISSIONED NAME OF NOTARY PUBLIC



JACKSONVILLE PORT AUTHORITY

JPA FPN #: T2021.07

CONTRACT RELATED DOCUMENTS

FOR

DESIGN-BUILD TERMINAL FACILITIES BUILDINGS

Contract No.: C-1752

TALLEYRAND MARINE TERMINAL

CONTRACT RELATED DOCUMENTS

INDEX

ITEM	PAGE NO(S).
GENERAL CONDITIONS	GC-1 TO GC-41
SPECIAL CONDITIONS	SC-1 TO SC-8
REQUIRED LIMITS OF INSURANCE	RLI-1 TO RLI-2
CERTIFICATE OF INSURANCE COMPLIANCE	COIC-1 TO COIC-3
APPLICATION FOR PAYMENT	AFP-1 & AFP-2
CONTRACTOR'S REQUEST FOR CLARIFICATION	CRC
REQUEST FOR INFORMATION	RFI
AGREEMENT BETWEEN OWNER AND CONTRACTOR	AGR-1 TO AGR-4
CERTIFICATE OF CONTRACT COMPLETION	FCC
CERTIFICATE OF SUBSTANTIAL COMPLETION	SUBCOM
CONSENT OF SURETY COMPANY TO FINAL PAYMENT	CONSUR
OWNER'S MINIMUM PROJECT WORK RULES	PWR-1 TO PWR-2
OWNER'S SAFETY GUIDELINES	PSG-1 TO PSG-3
PERFORMANCE BOND	PB-1 TO PB-4
STATUTORY PAYMENT BOND	SPB-1 TO SPB-3

GENERAL CONDITIONS

INDEX

ITEM	PAGE NO.
	GC-
SECTION I.: Preliminary Matters	2
1. Definitions.....	2
2. Contract Documents.....	3
3. Subcontracting or Assigning of Contract.....	4
4. Separate Contracts.....	5
5. Non-discrimination Provisions.....	5
6. Wage and Employment Laws	5
7. Royalties and Patents.....	6
8. Right to Audit.....	6
SECTION II.: The Work	7
1. Contractor's Responsibility.....	7
2. Execution of the Work.....	11
3. Substantial Completion	16
4. Tests and Inspections.....	17
5. Time.....	17
6. Warranties and Guarantees.....	18
SECTION III.: Changes and Disputes	19
1. Changed Conditions.....	19
2. Changes in the Work.....	19
3. Claims.....	22
4. Completion of Work by Owner	23
5. Default and Termination.....	24
6. Delays and Extensions of Time.....	26
7. Disputes.....	27
8. Recovery Rights, Subsequent to Final Payment.....	27
SECTION IV.: Administrative.....	29
1. "As-built" Drawings and Equipment Manuals	29
2. Conferences	29
3. Payments.....	30
4. Progress Schedule.....	32
SECTION V.: Insurance and Bond	34
1. Insurance and Indemnification.....	34
2. Surety Bonds.....	42

GENERAL CONDITIONS

SECTION I.: PRELIMINARY MATTERS

1. Definitions

- a. Owner: The Owner is JAXPORT or its designee authorized in writing. The words "Owner", "JAXPORT", "JPA" and "Authority" shall mean the same and are used interchangeably.

Owner Representative/Project Manager: The Owner will designate an individual or firm to be Project Manager for all work to be accomplished under the contract. All instructions and correspondence to the Contractor will be issued by the Project Manager and all requests, invoicing, and correspondence from the Contractor will be directed to the Project Manager. The Project Manager will interpret the terms and conditions of the contract and be the judge of the performance of the Contractor on behalf of the Owner.

All correspondence relating to the contract shall be addressed to:

Cliff Baker, P.E. (Retired)
JAXPORT
ENGINEERING SERVICES
POST OFFICE BOX 3005
JACKSONVILLE, FL 32206-0005

- b. Inspector: The Project Manager may appoint such Inspectors as he desires. They shall be authorized to inspect all work done, and materials furnished. They shall be authorized to call to the attention of Contractor personnel any failure of the Work or materials to conform to the specifications and contract. They shall have the authority to reject nonconforming materials and workman-ship, and construction methods or procedures which produce substandard results and to take appropriate action to avoid any dangerous or unsafe conditions. The presence of the Inspector shall in no way relieve the responsibility of the Contractor to comply with and perform all of the obligations specified in the contract documents. The Inspectors shall not be authorized to approve, direct, or establish any methods or procedures used by the Contractor in constructing the project. The Inspector is not authorized to approve any deviation from the contract documents nor any substitutions of materials or equipment.
- c. Approval: Where utilized in this contract, "approval" shall constitute a review by the Owner only to satisfy itself as to the general conformance of the subject as to the intent of the contract. Approval by the Owner does not indicate any responsibility of the Owner towards the design, materials, substitutions, dimensions, fit, function, strength, finish or any other quantity, capacity, or quality of the subject at hand. Approval by the Owner shall not relieve the Contractor from its responsibility for full compliance with the contract requirements, at his sole expense.

SECTION I.: PRELIMINARY MATTERS (... Continued)

- d. **Work:** Where used in these contract documents, the word "Work" shall include all actions, materials, tools, equipment and all appliances, machinery, appurtenances and engineering (when specified), and labor necessary to perform and complete the contract, and such additional items not specifically indicated or described which can be reasonably inferred as belonging to the scope and intent of the contract. The terms "Work" and "Project" shall mean the same and may be used interchangeably.
- e. **Consultant:** Where utilized by the Owner, the consulting firm or firms engaged by the Owner to provide professional services in conjunction with the planning, design, and construction of the Project will interpret the technical specifications and drawings, and will render judgments and decisions on matters of a technical nature as pertains to design and construction of the Project. The terms "Architect," "Architect/Engineer," "A/E," and "Engineer" shall all be construed to refer to the Consultant(s).
- f. **Contractor:** The individual, firm, company or corporation contracting with JAXPORT for performance of Work and/or furnishing of materials for construction of the Project is defined in the contract documents.
- g. **Certificate of Substantial Completion:** A written document representing a mutually agreed upon status of the progress of the Work as described in the contract documents, or a specified part thereof, between the Owner, the Contractor, and the Consultant whereby the Work is sufficiently complete and can be utilized for its intended purpose/ occupancy by the Owner without unreasonable inconvenience. The Owner reserves the right to make the final decision as to the status of the Work in reference to this definition.

2. Contract Documents

- a. **General:** The contract documents shall consist of the bidding documents, contract forms, conditions of the General Conditions, specifications, drawings, all addenda issued prior to the execution of the Agreement, the approved Project construction schedule(s), all amendments, change orders, and Engineer's response to Contractor's "Request for Information (RFI)" of the contract documents relating to construction issued by the Owner's representative. These form the contract, and what is required by any one shall be binding as if required by all. The intention of the contract documents is to include all labor, materials, equipment and other items necessary for the proper execution and completion of the Work so as to result in a fully operational and functional product. Any work, labor, equipment and materials that may reasonably be inferred from the specifications or drawings as being required to produce the intended result shall be supplied whether or not it is specifically called for in the contract documents. The contract Agreement shall be signed in duplicate by the Owner and the Contractor, unless otherwise stated.
- b. **Governing Law:** The terms and conditions of this contract will be governed by the laws of the State of Florida, and venue for any action shall be in Jacksonville, Florida.

SECTION I.: PRELIMINARY MATTERS (... Continued)

- c. Conflicts and Discrepancies: The Contractor shall take no advantage of any error or omission which he might discover in the plans or specifications but shall, within 5 working days, notify the Owner of such discovery, who will then make such corrections and interpretations as it deems necessary for reflecting the actual spirit and intent of the plans and specifications. Failure to make notice within 5 days to Owner by the Contractor will result in work performed at Contractor's own risk and Owner will have no liability for any claim resulting therefore.

The Owner, after receipt of written notice by the Contractor in resolving conflicts, errors, and discrepancies between the various contract documents generally, will give precedence in the following order:

- Approved Change Orders
- Addenda issued prior to receipt of bids
- The executed Agreement Form
- Owner's response to Contractor's Request for Information (Form RFI)
- Supplemental Instructions to Bidders
- Special Conditions of the specifications
- General Conditions of the specifications
- Technical specifications
- Drawings
- Other documents as listed on the Agreement between Owner and Contractor, Form FA
- Bid

Figure dimensions on drawings shall govern over scale dimensions, and detailed drawings shall govern over general drawings.

3. Subcontracting or Assigning of Contract

- a. The Contractor shall not subcontract more than 25 percent of the total value of jobsite Work, exclusive of the cost of all installed materials and equipment, without the prior written approval of the Owner. Qualifications of subcontractors may be required in the same manner as provided for the Contractor elsewhere in this contract (see "Instructions to Bidders").
- b. The Contractor agrees that it shall not subcontract, assign, delegate, or otherwise dispose of the contract, the duties to be performed under the contract, or the monies to become due under the contract without the Owner's prior written consent.
- c. Contracts between the Contractor and subcontractors or suppliers shall be in accordance with the terms of this agreement as applicable.
- d. Subcontracted work volume may reflect the JSEB Participation goals described in the "Instructions to Bidders".

SECTION I.: PRELIMINARY MATTERS (... Continued)

4. Separate Contracts

The Owner reserves the right to let other contractors perform work without conflict on the same or adjacent property. The Contractor shall cooperate and coordinate with any such other contractor(s).

5. Non-discrimination Provisions

The Contractor, upon execution of the Project agreement, certifies that it meets and agrees to the following provisions:

- a. The Contractor agrees that it will not discriminate against any employee or applicant for employment because of race, color, religion, sex, national origin, marital status or disability nor will it discriminate in hiring nor fail to make reasonable accommodation for qualified handicapped employees.
- b. The Contractor agrees to comply with all applicable federal, state and local laws, including the Civil Rights Act 1964, as amended. The Equal Employment Opportunity Clause in Section 202, Paragraphs 1 through 7 of Executive Order 11246, as amended, relative to Equal Employment and the implementing rules and regulations of the Office of Federal Contract Compliance Programs are incorporated herein by specific reference. The Affirmative Action Clause in Section 503 of the Rehabilitation Act of 1973, as amended, relative to Equal Opportunity for the Disabled is incorporated herein by specific reference. The Affirmative Action Clause in 38 U.S.C. Section 2-12 of the Vietnam Veterans' Readjustment Assistance Act of 1974, relative to Equal Employment Opportunity for the special disabled veteran and veterans of the Vietnam era, is incorporated herein by specific reference.
- c. An entity or affiliate who has been placed on the State of Florida's discriminatory vendor list may not submit a bid on a contract to provide any goods or services to a public entity, may not submit a bid on a contract with a public entity for the construction or repair of a public building or public work, may not submit bids on leases of real property to a public entity, may not be awarded or perform work as a contractor, supplier, subcontractor, or consultant under a contract with any public entity, and may not transact business with any public entity.

To view a current list, visit:
http://dms.myflorida.com/business_operations/state_purchasing/vendor_information/convicted_suspended_discriminatory_complaints_vendor_lists
- d. The Contractor agrees that if any of the obligations of this contract are to be performed by a subcontractor, the provisions of this Section I.5 shall be incorporated into and become a part of the subcontract.

6. Wage and Employment Laws

- a. The Contractor shall observe and comply with Federal, State, and local laws

SECTION I.: PRELIMINARY MATTERS (... Continued)

relating to wages, rates of pay, and employment requirements, including applicable E.E.O. and Affirmative Action requirements.

- b. ARTICLE 1, SECTION 6, OF THE CONSTITUTION OF THE STATE OF FLORIDA RECOGNIZES THAT THE RIGHTS OF PERSONS TO WORK SHALL NOT BE DENIED ON ACCOUNT OF THE MEMBERSHIP OR NON-MEMBERSHIP IN ANY LABOR UNION OR LABOR ORGANIZATION.

7. Royalties and Patents

The Contractor shall pay all royalties and license fees. The Contractor shall defend all suits or claims for infringement of any patent rights and shall save the Owner harmless from loss on account thereof.

8. Right to Audit

The Contractor agrees to provide JAXPORT or any of their authorized representative's access to any books, documents, papers and records of the Contractor which are directly pertinent to this contract for the purposes of making audits, examinations, excerpts and transcriptions. JAXPORT will also be afforded access to all of the Contractor's records, including but not limited to payroll records, training books, correspondence, instructions, drawings, receipts, vouchers, memoranda and similar data relating to this Contract, and the Contractor will preserve all such records for (3) three years, or for such longer periods a may be required by law, after final payment.

The Contractor agrees to permit any of the foregoing parties to reproduce by any means whatsoever or to copy excerpts and transcriptions as reasonably needed.

The Contractor shall pay all royalties and license fees. The Contractor shall defend all suits or claims for infringement of any patent rights and shall save the Owner harmless from loss on account thereof.

GENERAL CONDITIONS

SECTION II.: THE WORK

1. Contractor's Responsibility.

- a. Until substantial completion or final acceptance of the Work (whichever comes first) by the Owner, the Work shall be under the complete care, custody, and control of the Contractor. The Contractor shall assume all risks of loss during its period of custody.
- b. The Contractor shall supervise and direct the Work using its best skill, judgment, and attention. The Contractor shall be solely responsible for all construction means, methods, techniques, sequences and procedures, including implementation of the Contractor's Quality Control Program, the prudent exercise of all reasonable safety precautions, and for coordinating all portions of the Work under the contract to affect a timely completion, and resolving any delay or damages between itself and any other Contractor without involvement of the Owner.
- c. Unless otherwise specifically noted, the Contractor shall provide and pay for all labor, materials, equipment, tools, construction equipment and machinery, water, heat, utilities, transportation, and other facilities and services necessary for the proper execution and completion of the Work.
- d. The Superintendent shall maintain one complete set of the contract documents including approved shop drawings on the jobsite at all times that Work is underway.
- e. The Contractor warrants to the Owner that all materials and equipment incorporated in the Work will be new unless otherwise specified, and that all Work will be of good quality, free from faults and defects, and in conformance with the contract documents. All Work not so conforming to these standards may be considered defective. In the event Work is rejected by the Project Manager, the Contractor shall correct, remove, and/or reconstruct such Work to conform to contract requirements at his sole expense including any testing or engineering costs necessitated thereby.
- f. The Contractor shall pay all sales, consumer use, and other similar taxes required by laws and secure all permits, fees, and licenses necessary for the execution of the Work.
- g. The Contractor shall promptly give all notices and comply with all laws, ordinances, permits, rules and regulations, order, and any public authority bearing on the performance of the Work, and shall notify the Owner if the drawings and specifications are at variance therewith, failure to do so shall result in Contractor's responsibility for any losses or damages associated with the work.
- h. The Contractor shall be responsible for the acts and omissions of all its employees, all subcontractors, suppliers, agents and employees and all other

SECTION II.: THE WORK (... Continued)

persons performing any of the Work under a contract with, or under the supervision of the Contractor.

- i. Contractor is required to record daily, the progress of the project and submit electronically in E-Builder; daily progress reports to the OWNER including information on the subcontractor's work, and the percentage of completion.
- j. Contractor is required to and hereby agrees that it will exert every reasonable and diligent effort to assure that all labor employed by the Contractor and its sub-contractors for Work on the Project shall work in harmony with and be compatible with all other labor being used by building and construction contractors now or hereafter on the site of work covered by this contract.

Contractor further agrees that this requirement will be included in all subcontracts of the subcontractor as well as in the Contractor's own contract provided, however, that this provision shall not be interpreted or enforced so as to deny or abridge on account of membership or non-membership in any labor union or labor organization, the right of any person to work as guaranteed by Article I, Section 6 of the Florida Constitution.

- k. Submittal Procedures.

Contractor shall submit each shop drawing Submittal for review electronically in E-Builder.

Preliminary Shop Drawing Data: Within 20 days after the Award of the Contract the Contractor shall submit to the Project Manager a complete listing of manufacturers for all items for which shop drawings are to be submitted.

Shop Drawing Submittal Schedule: Within 30 days after the Notice to Proceed, the Contractor shall submit to the Project Manager a complete schedule of shop drawing submittals fixing the respective dates for submission, the beginning of manufacture, testing, and installation of materials, supplies and equipment, noting those submittals critical to the progress schedule.

Submittal Log: Contractor shall provide an accurate updated log of submittals maintained by the Contractor and subject to review by JAXPORT at each scheduled progress meeting.

When reviewed by JAXPORT each of the shop drawings will be identified as having received such review, being so labeled and dated. Shop drawings labeled "REJECTED" will be returned to the Contractor for correction and re-submittal with the required correction indicated on the shop drawing or listed on a "Shop Drawing Review sheet".

If submitted drawings or schedules show a departure or variation from the Contract Requirements which are in the interest of JAXPORT and to be so

SECTION II.: THE WORK (... Continued)

minor as not to involve a change in Contract Price or time for performance, JAXPORT may return the reviewed drawings without noting an exception.

Re-submittals will be handled in the same manner as first submittals. On re-submittals, the Contractor shall direct specific attention on the transmittal and on re-submitted shop drawings to revisions other than the corrections requested by the Project Manager on previous submissions. The Contractor shall make any corrections required by the Project Manager.

The Project Manager and JAXPORT'S Engineer of Record will review a Submittal/re-submittal a maximum of two (2) times after which the cost of review will be borne by the Contractor at JAXPORT'S Project Manager and Engineer of Record's standard hourly rate. No partial submittals will be reviewed. Submittals not complete will be returned to the Contractor, and will be considered "Rejected" until properly resubmitted.

Contractor shall submit a minimum of six (6) sets, plus additional sets as required by his Subcontractors, of each shop drawing Submittal for review.

If catalog sheets or prints of manufacturers' standard drawings are submitted as Shop Drawings, any additional information or changes on such drawings shall be typewritten or lettered in ink.

The minimum size for shop drawings shall be 11" X 17". Each shop drawing shall be clear, thoroughly detailed and shall have listed on it all Contract Documents references, drawing number(s), specification section number(s) and the shop drawing numbers of related work. Shop drawings must be complete in every detail, including location of the Work. Materials, gauges, methods of fastening and spacing of fastenings, connections with other work, cutting, fitting, drilling and any and all other necessary information per standard trade practices or as required for any specific purpose shall be shown.

Where professional calculations and/or certification of performance criteria of materials, systems, and or equipment are required, the Project Manager is entitled to rely upon the accuracy and completeness of such calculations and certifications submitted by the Contractor. Calculations, when required, shall be submitted in a neat clear and easy format to follow.

Contractor shall keep one set of Shop Drawings marked with Project Manager's and/or Engineer of Record's approval at the job site at all times.

- I. Shop Drawings and Samples.
 - (1) The Contractor shall furnish all samples and shop drawings as required for approval by the Owner. Details, number of copies required, and format will be mutually agreed upon at the Preconstruction Conference.
 - (2) Approval of shop drawings, samples, materials, substitutions, or

SECTION II.: THE WORK (... Continued)

equipment deviating in any dimension, fit, strength, finish, capacity, or other quality shall not relieve the Contractor from full compliance with the contract requirements, at its sole expense, unless such exceptions, deviations, dimensions, substitutions, etc. are specifically identified and marked for attention on the shop drawing submittals and signed by the Contractor at time of submission. Approval of such specifically marked shop drawings shall permit the altered or substituted Work provided that any change in the contract price occasioned thereby is accomplished per Section III, "General Conditions". The Contractor shall bear full responsibility for coordinating proposed deviations, substitutions, dimensional changes and the like with all other affected trades, and for the full cost of any other subsequent modifications or changes to the Work necessitated thereby.

- (3) The Contractor and if applicable, the Subcontractor(s) shall thoroughly check, coordinate, stamp, sign and approve all shop drawings prior to submittal to the Owner for review. If it appears to the Project Manager that such review, coordination, and approval has not been done or is not adequate, the shop drawings will be returned to the Contractor without action. The Contractor shall bear the sole responsibility for performance of Work or ordering requiring shop drawing approval, in advance of such approval.
 - (4) THE CONTRACTOR SHALL BEAR THE SOLE RESPONSIBILITY FOR ANY DELAYS TO THE WORK OCCASIONED BY OR RESULTING FROM ITSELF OR ITS AGENTS, SUBCONTRACTORS, SUPPLIERS, OR EMPLOYEES' DELAY OR FAILURE TO FURNISH COMPLETE, CORRECT, COORDINATED SHOP DRAWINGS IN A TIMELY MANNER. DELAYS INCURRED DUE TO REJECTION OF INCOMPLETE AND/OR NON-CONFORMING SHOP DRAWINGS SHALL BE SOLELY THE RESPONSIBILITY OF THE CONTRACTOR, AND NO ADDITIONAL CONTRACT COST OR TIME SHALL BE ALLOWED ON ACCOUNT OF SUCH DELAYS.
- m. The Owner will furnish such information as is available at the time of contract award as to control points, benchmarks, recent surveys, or soundings concerning the worksite, and adjacent facilities, utilities, or structures. The Contractor, not the Owner, shall be responsible for any and all verifications required, extensions of survey control for the Work, ancillary surveying, location of centerlines, baselines, additional benchmarks, and any other measurements necessary for construction or design purposes, as appropriate.

Any markers or stakes set by the Owner or its representatives for control, inspection, or reference purposes during construction shall be preserved and left intact and undisturbed by the Contractor, unless in the way of construction. Prior to removal or relocation of any such marker by the Contractor, when necessary, the Contractor shall so inform the Owner's representative at the jobsite. Any such markers negligently destroyed or disturbed by the Contractor shall be restored at his expense.

SECTION II.: THE WORK (... Continued)

2. Execution of the Work.

- a. General. The Contractor shall preserve and protect from damage all property along the line of work, or which is in the vicinity of, or is in any way affected by the Work, the removal or destruction of which is not called for by the plans. This applies, but is not necessarily limited to public and private property, public and private utilities, trees, shrubs, signs, monuments, fences, guardrails, pipe and underground structures, wharves, railroads, bridges, roadways (except natural wear and tear resulting from legitimate use thereof by the Contractor etc.), and whenever such property is damaged due to the activities of the Contractor, it shall be immediately restored to a condition similar or equal to that existing before such damage or injury was done by the Contractor, and at his own expense, or he shall make good such damage or injury in a manner acceptable to the Owner. In case of failure on the part of the Contractor to restore such property or to make good such damage or injury, the Owner may upon 48 hours' notice proceed to repair, rebuild or otherwise restore such property as may be deemed necessary, and the cost thereof will be deducted from any monies due or which may become due the Contractor under the contract.
- b. Superintendence. The Contractor shall provide a qualified Superintendent on the Work throughout its progress, and shall specifically require that the Superintendent be present on the site at all times when any Work is being performed by itself or any of its subcontractors. Qualified Superintendent shall have a minimum of 10 years of construction experience, five of which are on similar projects in that capacity. All communications given to the Superintendent shall be as binding as if given to the Contractor. Once assigned, the Contractor's Superintendent shall not be replaced without prior written notice to the Owner. The Owner reserves the right to reject the assignment or reassignment of the Contractor's Superintendent. The Superintendent shall have full authority to execute the orders or directions of the Project Manager and to obtain or supply promptly any materials, tools, equipment, labor, and incidentals which may be required. The Contractor must provide on-site supervision at all times when work is being done. If, in the event that it is absolutely necessary for the Superintendent to be absent from the site, the Contractor shall notify the Project Manager, in writing, the assignment of the person on-site who will act in its place and be responsible for the project. This person must be an employee of the Contractor. Such superintendence shall be furnished regardless of the amount of Work sublet.
- c. Design Engineering. Where design engineering is the responsibility of the Contractor, the Contractor must assure that the engineer who certifies the design is appropriately authorized to do so according to the regulations and laws of the local community and the State of Florida.
- d. The Contractor shall have a responsible person available reasonably near the worksite and "on-call" on a 24-hour basis, 7 days a week; in order that it may be contacted in emergencies and in cases where immediate action must

SECTION II.: THE WORK (... Continued)

be taken to maintain traffic or to handle any other problem that might arise. The designated individual shall have full authority to take actions necessary to resolve such situations as previously described. For compliance with this requirement the furnishing of a local telephone number (non-toll) where such person can be directly reached will suffice.

- e. Except in the interest of safety or protection of persons, or the Work, or property at the site or adjacent thereto, and except as may otherwise be indicated in the "Special Conditions", all Work at the site shall be performed during regular working hours, and Contractor shall not permit overtime Work or the performance of Work on Saturday, Sunday, or any legal holiday without Owner's consent given after prior written notice to Owner's Project Manager. In general, all Work shall be performed during daylight hours. For special operations, night Work may be done if so authorized in writing. No night Work shall be performed unless adequate artificial lighting has been provided and has been approved by the Inspector.
- f. The Contractor shall not begin new items of Work to the prejudice of Work already started. The Owner may require the Contractor to finish a section or area on which Work is in progress before Work is started on an unrelated or additional section or area, unless the Contractor can clearly demonstrate to the Project Manager on a sound, rational, and convincing basis that its intended action is in the best interest of the Project.
- g. The Contractor shall at all times conduct the Work in such a manner and in such sequence as to insure the least practicable interference with traffic. The Contractor's vehicles and other equipment shall be operated in such a manner that they will not be a hazard or hindrance to the public. Materials stored on the worksite shall be placed so as to cause as little obstruction as possible.
- h. The Contractor shall arrange his work and dispose of his materials so as not to interfere with the operations of other contractors engaged upon adjacent work, and to join his work to that of others in a proper manner in accordance with the spirit of the plans and specifications, and to perform his work in the proper sequence in relation to that of other contractors, all as may be directed by the Owner. Each contractor will be held responsible directly to the Owner or any other contractor for any damage done by him, his agents, or his subcontractors to the work performed by another contractor. The Owner shall not be liable for damages caused between contractors.
- i. The Contractor shall so conduct his operations and maintain the Work in such condition that adequate drainage will be in effect at all times. Existing functioning storm sewers, gutters, ditches, and other run-off facilities shall not be unnecessarily obstructed.
- j. Heavy equipment shall not be operated close enough to new or previously existing structures to cause damage, disturbance or displacement.
- k. The Contractor shall provide qualified and acceptable personnel to organize,

SECTION II.: THE WORK (... Continued)

schedule, manage, layout, and construct the Work as required by the contract documents and shall assure that all Project executives, superintendents, and foremen employed by it on this Project are competent, knowledgeable in the Work, conscientious, attentive to the Project, and reliable. All workers must have sufficient skills and experience to properly perform the work assigned them. Welder qualification records will be furnished by the Contractor at no cost to the Owner. All workers engaged on specialty work or detailed (highly skilled) work, or in any recognized trade shall have had sufficient experience in such work to perform it properly and satisfactorily and to operate the equipment involved, and shall make due and proper effort to execute the Work in the manner prescribed in the specifications, or the Owner may take appropriate action as prescribed below.

The Contractor shall at all times maintain good discipline and order at the site. Whenever the Project Manager has determined that any person employed by the Contractor is incompetent, unfaithful, malevolent, intemperate, disorderly or insubordinate, such person shall, upon notice to the Contractor's Superintendent, be promptly removed from the Work and shall not again be employed on it except with the written consent of the Project Manager. Should the Contractor upon due notice fail to remove such person or persons, the Owner may withhold all monies which are or may become due to the Contractor, or may suspend the Work until such orders to remove said person or persons have been accomplished as set forth in Article 8(i). The Contractor shall protect, defend, indemnify and hold the Owner, its agents, officials, and employees harmless from any and all claims, actions or suits arising from such removal, discharge, or suspension of unsuitable employees of the Contractor.

- l. The Contractor shall at all times keep the premises free from accumulation of waste materials and rubbish caused by the Work, and at the completion of the Work shall remove all rubbish, waste, salvage and surplus materials which resulted from the Work. The Contractor shall also remove all tools, construction equipment and machinery and shall leave the Project "broom clean", unless otherwise specified. All surplus and salvage material shall become the property of the Contractor unless otherwise specified in the contract documents.
- m. The Owner shall have the authority to suspend the Work wholly, or in part, for such period or periods as may be deemed necessary due to unsuitable weather or other conditions which are considered unfavorable for the prosecution of the Work; to accommodate actions, or for such time as is necessary due to the failure on the part of the Contractor to carry out orders given, or to comply with any or all provisions of the contract. Such suspension shall be ordered in writing by the Project Manager giving the Contractor, in detail, the reasons for the suspension and under what circumstances or conditions the Work may be permitted to resume.

Whenever the Work is suspended by the Owner for reasons other than the

SECTION II.: THE WORK (... Continued)

fault of the Contractor, an extension of time for completion of the Work due to such suspension may be made as allowed for in other sections of this contract.

Time extension shall be the Contractor's sole remedy unless otherwise agreed upon in writing prior to the commencement of work.

- n. The Contractor shall not suspend operations or remove equipment or materials necessary for the completion of the Work without the prior permission of the Owner.
- o. Cooperation with Port Operations.
 - (1) The Contractor understands that the Work will be performed on, or in the near vicinity of an operating marine terminal. The Contractor acknowledges that ship schedules and terminal operations take precedence over the Contractor's activities. Contractor shall provide upon request, manpower and equipment loading schedule for the project.
 - (2) The Owner will, insofar as possible, schedule berthing of ships, and general terminal operations, so as not to interfere with the Work of the Contractor. The Owner will review the schedule presented by the Contractor at the Preconstruction Conference and advise the Contractor of any known conflicts that may exist with terminal operations. The Contractor shall adjust its schedule to avoid those conflicts and ensure that its activities will not interfere or cause interference with terminal operations, at no cost to the Owner.
 - (3) Considering that ship schedules are not precise due to weather and delays at other ports, the Contractor will be notified a minimum of 24 hours prior to the expected arrival of a ship that will be berthed in, or affect the area of the Contractor's Work. The Contractor may be required to curtail its activities in the area affected to the satisfaction of the Project Manager until the construction site is available again at no cost to the Owner.
 - (4) The Contractor's Superintendent, however, during the course of the Work, shall contact the Terminal Director designee by telephone or personal contact, twice each day (early morning and late afternoon) concerning ship traffic schedules and cargo handling activities so as to minimize Contractor's "downtime" and improve his scheduling efforts.
 - (5) When the Work is stopped by the Authority for its convenience, or vessels are berthed in locations so as to impede the Contractor's Work, the total number of calendar days of delay shall be added to the time allowed for the completion of the Project which shall be the sole remedy available to the Contractor.
 - (6) When it is necessary that a change or interruption be made in terminal operations in order to carry out a construction operation, the Contractor shall submit a request electronically in E-Builder with full

SECTION II.: THE WORK (... Continued)

details including a pre-approved schedule at least 72 hours prior to the time the change or interruption is required. The Owner shall make all reasonable efforts to comply with the request of the Contractor. The Contractor shall not proceed with such Work until it has received written notice from the Owner to so proceed.

- p. Failure of Contractor to Maintain Satisfactory Progress.
- (1) Time is of the essence in this contract, and as delay in the prosecution of the Work will adversely impact the Owner's business, it is important that the Work be prosecuted to completion. Moreover, the cost to the Owner for the administration of the contract, including engineering, inspection, and supervision, will be increased as the construction period is lengthened.
 - (2) The Contractor may be declared delinquent because of unsatisfactory progress under this contract when the contract time allowed has not been entirely consumed, but the Contractor's progress at any check period does not meet at least one of the following two tests:
 - (a) The percentage of dollar value of completed Work with respect to the total amount of the contract is within 15 percentage points of the percentage of contract time elapsed.
 - (b) The percentage of dollar value of completed Work is within 15 percentage points of the dollar value which should have been performed according to the Contractor's own progress schedule previously approved by the Owner.
 - (3) The Contractor will be declared delinquent because of unsatisfactory progress under this contract should either of the following circumstances occur:
 - (a) The contract time allowed has been consumed and the Work has not been completed.
 - (b) The contract time allowed has not been entirely consumed, but the Contractor's progress at any check period does not meet either of the two tests described under Sub-article (2) above.
 - (4) A Contractor determined delinquent will be disqualified from further bidding by the Director of Procurement and also will not be approved as a subcontractor so long as the delinquency status exists. Also, any individual, firm, partnership or corporation affiliated with a delinquent Contractor to the extent that it is dependent upon the delinquent Contractor for either personnel, equipment, or finances shall likewise be disqualified. The Owner additionally reserves all rights and options pertaining to available legal remedies for such delinquency. A Contractor disqualified under the requirements of this Article will be removed from a delinquent status upon receipt of satisfactory evidence by the Owner's Project Manager and approval of Procurement that its progress is no longer delinquent, provided the

SECTION II.: THE WORK (... Continued)

contract time has not lapsed.

- (5) The principal progress verification will occur monthly and will generally coincide with receipt by the Owner's Project Manager of the Contractor's monthly Application for Payment and Work Progress Schedule.
- (6) Preliminary notices of delinquency will be sent to the Contractor by facsimile mail immediately thereafter, and confirmed by certified mail. The Contractor, once given such a preliminary notice of delinquency, will not be finally declared delinquent until a period of 10 calendar days after the preliminary notice has elapsed. During this 10-day period, the affected Contractor may request an extension of time or present other considerations that would affect its delinquency to which it feels it is entitled. Final notification of delinquency will be made by certified mail after the expiration of this 10-day period provided no extensions of time or other considerations are deemed proper by the Owner, and provided the delinquency status has not been corrected. Contractor shall provide an acceptable recovery schedule to Owner for approval.

Owner's failure to terminate for delinquency shall not serve as a waiver by the Owner.

- (7) The Owner may grant extensions of time during the prosecution of the Work, as allowed under the contract provisions regardless of the Contractor's delinquency status. The contract will be considered complete when all Work has been completed and accepted by the Owner, and final payment has been issued to the Contractor.

3. Substantial Completion

The Substantial Completion, as defined in the "Definitions" of Section I.1. g, will be initiated in writing by the Contractor and/or the Owner for the purpose of making available the stated Work, or a specified part thereof, for its intended use. The Owner and the Contractor will conduct an inspection of the stated Work for compliance with the contract documents. The Owner will have prepared a written Punch List of all items and/or the deficiencies for the Work covered by the Certificate of Substantial Completion. The Punch List shall become a part of the Certificate of Substantial Completion and must be completed prior to final acceptance of the Work. If the Owner agrees that the Work is ready for occupancy, a Certificate of Substantial Completion will be prepared by the Owner on the form included in the contract documents. The Statement shall be completed in its entirety and shall be signed by the Engineer, Contractor, Tenant and Owner, where applicable. Final payment and any retainage may be withheld until completion of the Punch List items by the Contractor, and accepted by the Owner. The Owner may supplement the Punch List at any time based on the disclosure of defective or incomplete work.

SECTION II.: THE WORK (... Continued)

4. Tests and Inspections

- a. Except as specifically stated in writing by the Owner, the Contractor shall establish and conduct its own quality testing program for materials and other Work performed thereon under this contract. Testing may include but not be limited to soils, aggregates, compaction, masonry, concrete, asphalt, painting, metals, pressure tests, welding, coatings, insulation, water quality, electrical circuitry, machinery, equipment or other applicable items. The Contractor shall, prior to the Preconstruction Conference, furnish electronically in E-Builder to the Owner a listing or schedule of testing it proposes to conduct for informational purposes. Results of such tests as performed by the Contractor shall be furnished electronically in E-Builder to the Owner within 48 hours of such testing, for information. No separate payment will be made by the Owner for any testing accomplished by the Contractor but the cost thereof will be considered as included in the overall contract price for the related items of Work.
- b. The Owner may employ, at its expense, an independent testing laboratory for the purpose of performing such tests as may be deemed necessary by the Owner.

If any Work or materials are found to be deficient as a result of such tests, the Contractor shall promptly correct same, or replace, in accordance with the specifications, and it may be required to revise and upgrade both construction and quality control procedures. If the Owner deems it necessary that additional testing shall be made of such correction or replacement, the Contractor shall pay the costs thereof.

- c. The Owner reserves the right to inspect any and all parts of the Work underway for conformance with the contract requirements. The making of tests by the Contractor, regardless of their indication, shall not relieve the Contractor of sole responsibility for Work that is defective or not in accordance with the requirements of the contract.

Should the cost of remediation of deficient work be commercially wasteful, the Owner at its sole option may retain the nonconforming work for no cost to the Owner for that work.

5. Time

- a. All time limits stated in the contract documents shall be consecutive calendar days unless otherwise stated.
- b. The contract completion time shall be as shown in the "Special Conditions". Timely completion is an essential element of this contract. Prevailing conditions of weather and environment at the worksite and the Owner's continuing port operations in the vicinity have been taken into account in establishing the contract time allowed for the Work.
- c. The Notice to Proceed will not be given until after receipt of evidence of insurance (in the manner specified) and contract bonds, and following the

SECTION II.: THE WORK (... Continued)

Preconstruction Conference. If the Preconstruction Conference is waived by the Owner, the Notice to Proceed will be issued immediately upon receipt of the required bonds and certificates by the Owner.

6. Warranties and Guarantees.

- a. The Contractor shall correct any Work that fails to conform to the requirements of the contract documents where such failure to conform appears during the progress of the Work, and shall remedy any defects due to faulty materials, equipment or workmanship which appears within the warranty period. The Warranty Period is as specified in the "Special Conditions", unless the Technical Specifications require a longer warranty period for all or portions of the Work. The provisions of this condition apply to work done by subcontractors, as well as to work done by direct employees of the Contractor. The Contractor shall insure that its subcontractors/suppliers are bound by this requirement.

- b. The Contractor shall furnish all written warranties/guarantees for any materials or equipment electronically in E-Builder, which are required under this contract, or separately warranted by the manufacturers. Final payment shall be withheld from the Contractor until all warranty documents have been furnished to the Owner. All warranties shall be issued consistent with the requirements of these contract documents.

GENERAL CONDITIONS

SECTION III.: CHANGES AND DISPUTES

1. Changed Conditions.

The Contractor shall promptly and before such conditions are disturbed, notify the Owner in writing of: a) subsurface or latent physical conditions at the site differing materially from those indicated in the contract documents, b) previously unknown physical conditions at the site of an unusual nature, differing materially from those ordinarily encountered and generally recognized as inherent in Work of the character provided for in this contract, or c) underground utilities or other obstructions not shown on the plans or reasonably expected to exist in the way of the Work at such location(s).

Notification shall be within 5 calendar days of discovery by the contractor. The Owner shall promptly investigate the conditions, and if it finds that such conditions do so materially differ and cause an increase or decrease in the Contractor's cost of, or the time required for performance of this contract, an equitable adjustment may be made, and the contract modified in writing accordingly by Change Order. Any claim by the Contractor for adjustment under this clause shall not be allowed unless timely notification has been made by the Contractor, or unless the Owner has granted a further period of time for determination of the extent of delay, magnitude of changed conditions, or determination of corrective action required.

2. Changes in the Work.

a. Change Orders - General. JAXPORT does not anticipate the issuance of Change Orders to the contract. The Contractor should not anticipate Change Orders; nor view any Change Orders that should occur as the opportunity for windfall profit. The Owner may authorize changes in the work consisting of additions, deletions or modifications to scope or schedule and the contract price or time (or both) being adjusted accordingly. All such changes in the Work shall be authorized by a written Change Order which shall document the change and specify any contract modifications such as price or schedule. No changes to the Work are authorized until the Contractor and the Owner have executed a formal Change Order. Verbal instructions do not constitute a Change Order.

(1) Either the Owner or the Contractor may initiate a Change Order request. In either event, the Contractor shall promptly prepare and submit electronically in E-Builder to the Owner a detailed justification for the Change Order request (when initiated by the Contractor) and a detailed quotation for the changed work, both time and money. The detailed quotation shall be complete and definitive as to the true costs of the changed work. The Owner will also require a complete breakdown of all costs that will be experienced by Contractor and all sub-tier contractors. Single line statements are not acceptable. The breakdown of costs may include, but are not limited to:

SECTION III.: CHANGES AND DISPUTES (... Continued)

- Labor Hours (broken down by craft)
- Materials (broken down by units)
- Equipment (broken down by units)
- Transportation (specify)
- Supervision (specify)
- Taxes (specify)
- Permits (specify)
- Insurance and Bonding (specify)
- Mobilization (show detail of cost)
- Demobilization (show detail of cost)
- Any other information requested by the Owner
- Mark-up for Profit and Overhead (see Section III 2.a.2.)

The breakdown of time shall include a thorough justification for any extension of the contract completion date which may include a time impact analysis, if requested by the Owner. Only those items of Work that directly affect the "critical path" of the Project will be considered for time extension.

Additional equipment costs on change orders: For any machinery or special equipment (other than Small tools), including fuel and lubricant, the Contractor will receive 80% of the "Rental Rate Equipment Watch or an amount less than" for the actual time that such equipment is in operation on the work, and 50% of the "Rental Rate Equipment Watch or an amount less than" for the time the equipment is directed to standby and remain on the project site, to be calculated as indicated below. The equipment rates will be based on the latest edition (as of the date the work to be performed begins) of the "Rental Rate Equipment Watch for Construction Equipment or an amount less than" or the "Rental Rate Equipment Watch for Older Construction Equipment or an amount less than," whichever is applicable, as published by Equipment Watch, Penton Media, Inc. (version current at the time of bid), using all instructions and adjustments contained therein and as modified below. On all projects, the Engineer will adjust the rates using regional adjustments and Rate Adjustment Tables according to the instructions in the Equipment Watch.

Allowable Equipment Rates will be established as set out below:

(1) Allowable Hourly Equipment Rate = $\text{Monthly Rate} / 176 \times \text{Adjustment Factors} \times 80\%$ or an amount less than.

(2) Allowable Hourly Operating Cost = $\text{Contractors Documented Cost} \times 80\%$ or an amount less than.

(3) Allowable Rate per Hour = $\text{Rental Rate Equipment Watch Hourly Equipment Rate} \times 80\% + \text{Contractors Hourly Operating Cost}$ or an amount less than.

(4) Standby Rate = $\text{Allowable Hourly Equipment Rate} \times 40\%$ or an

SECTION III.: CHANGES AND DISPUTES (... Continued)

amount less than.

The Monthly Rate is The Basic Machine Rate plus Any Attachments or an amount less than.

Standby rates will apply when equipment is not in operation and is directed by the Engineer to standby at the project site when needed again to complete work and the cost of moving the equipment will exceed the accumulated standby cost. Standby rates will not apply on any day the equipment operates for eight or more hours. Standby payment will be limited to only that number of hours which, when added to the operating time for that day equals eight hours. Standby payment will not be made on days that are not normally considered work days on the project.

Jaxport will allow for the cost of transporting the equipment to and from the location at which it will be used. If the equipment requires assembly or disassembly for transport, Jaxport will pay for the time to perform this work at the rate for standby equipment or an amount less than.

Equipment may include vehicles utilized only by Labor, as defined above.

- (2) The percentage mark-up for those items listed in Section III, Paragraph 2.a.1. shall be limited to 15 percent. All subcontract costs will be limited to 5 percent mark-up per tier, with a maximum of 10% regardless of the number of tiers.
- (3) All submissions of costs shall be in a form that is acceptable for verification by the Owner. Vendor quotations or Purchase Orders shall support material costs. Labor and supervision costs shall be supported by typical certified payroll documents. Equipment costs must be within the norm of published equipment rental rates for the Jacksonville area.
- (4) The pricing of Change Orders shall be determined in one of three ways:
 - (a) For changes in Work for which unit prices were already established in the contract, the established unit prices shall also apply to work performed under the Change Order. Established contract unit prices are all inclusive of costs, overhead and profit and shall not incur any additional mark-up.
 - (b) Force Account: Upon written directive of the Owner, the Contractor shall perform the work utilizing the "time and materials" method of pricing, under which all costs are auditable and payment to the Contractor will be limited to those actual expenses, plus the mark-ups allowed in Section III. 2.a. (2). The Change Order will be limited to an estimated cost not-to-exceed amount for fiscal control. Should this amount be reached due to unforeseen conditions, an additional Change Order will be

SECTION III.: CHANGES AND DISPUTES (... Continued)

sought.

- (c) By agreement of both parties of a lump sum amount for the change to the contract. Determination of the lump sum amount will require submission of a breakdown of costs as detailed in Section III.2.a.(1) and mark-ups applied from Section III. 2.a.(2), and any other information reasonably requested by Owner.
- b. Change Order Form. All Change Orders shall be executed on the form approved by JAXPORT. Execution of a Change Order resolves all issues of time and compensation. No other method of reservation of rights shall be recognized.
- c. The Contractor shall keep and present in such form as the Owner may direct, a correct and current account of all direct costs of the Work performed. All documentation shall be maintained according to generally accepted accounting practices (GAAP), in such form and detail as to be audited for accuracy and content. JAXPORT'S Project Manager shall periodically check and certify the costs. Payments shall be made to the Contractor based upon the certified costs of the Contractor, with mark-ups, as set forth in Section III.2.a.(2).
- d. Bond Liability. Any changes made in the specifications for the work by Change Order (whether such changes increase or decrease the amount thereof) or any change in the manner or time of payments made to the Contractor, or any change in the contract completion date occasioned by changed Work shall not, in any way, annul, release or affect the liability on the bond provided by the Contractor. The Contractor is solely responsible for notification of Surety of any Surety changes.

Notwithstanding the foregoing, it is understood and agreed that the Owner may, at any time, issue written instructions to the Contractor requiring changes within the scope of the work or schedule that are consistent with the general intent of the contract documents, at no extra cost to the Owner.

3. Claims.

- a. Claims for Extra Work. If the Contractor considers that any written instructions, acts, or omissions of the Owner or any of the Owner's agents, employees, consultants, contractors, subcontractors or suppliers have caused or will cause the Contractor to incur extra costs or time not included in the contract documents, the Contractor shall give written notice to Owner of such claim within 5 calendar days after the initial date of such acts, omissions, instructions or occurrence, and shall not proceed with the Work until receipt of the Owner's written directive to do so. Upon receipt of such a directive, the Contractor shall proceed in accordance therewith even though agreement may not have been reached as to whether said instructions require work that is within or outside of the scope of the contract documents or, if outside, the amount of the equitable price or time

SECTION III.: CHANGES AND DISPUTES (... Continued)

adjustment to which the Contractor is entitled for the performance thereof. No claim for such extra costs or time shall be allowable in the absence of the written directive of the Owner and the timely written notice by the Contractor. In the absence of either or both, the Contractor's claim for extra costs or time on account thereof shall be deemed to have been waived.

- b. Claims for Damages. Should the Contractor suffer injury or damage to any other party because of any act or omission of the other party or of any of its employees, agents, or others for whose acts it is legally liable, claim shall be made in writing to the Owner within 5 calendar days after the first observance of such injury or damage.
 - (1) Should the "no damages for delay" clause not be enforced by the court, the Contractor waives any claim for extended home office overhead that may result from any delay on the project.
 - (2) The Contractor specifically waives any right to seek attorney's fees and construction claim preparation costs from the Owner.
 - (3) The Contractor shall not present nor recover on any claim from the Owner based on any formula(s), hypothetical or statistical methodologies used in damage computation. The Contractor may only recover if it can provide documented pay records specifically indicating any alleged damage, loss, or cost.

4. Completion of Work by Owner

Upon declaration of default, the Owner shall have full power and authority to appropriate and/or use any or all materials and equipment on the site which are suitable and acceptable, and may enter into an agreement with others for the completion of the Work under the contract, or may use other methods which in the opinion of the Project Manager are required for the completion of the Work in an acceptable manner. All costs and charges incurred by the Owner because of the Contractor's default, including the costs of completing the Work under the contract, shall be charged against the Contractor and its Surety. In case the expense so incurred by the Owner is less than the sum which would have been payable under the contract if it had been completed by the defaulting Contractor, the defaulting Contractor shall be entitled to receive the difference.

Owner reserves their right to supplement, with additional workers and equipment, the Contractor's forces if Contractor is not reasonably projected to complete the project in a safe and timely manner. Owner shall give the Contractor 10 day's written notice of its intent to utilize supplemental forces. The Contractor shall have the primary responsibility to coordinate all work on the project and shall fully cooperate with all other forces.

In case the expense incurred by the Owner pursuant to this Section exceeds the sum which would otherwise have been payable under the contract, then the Contractor and its Surety shall be liable and shall pay the Owner the amount of the excess.

SECTION III.: CHANGES AND DISPUTES (... Continued)

If, after the 10-day default notification period, and prior to any action by the Owner to otherwise complete the Work under the contract, the Contractor should convincingly establish its intent and ability to prosecute the Work in accordance with the Owner's requirements, the Owner may elect to permit the Contractor to resume the Work in which case any costs to the Owner incurred by the delay or from any reason attributable to the delay will be reimbursed by the Contractor or Surety.

5. Default and Termination

- a. If the Contractor fails to begin the Work under the contract promptly upon receipt of the Notice to Proceed, or fails to perform the Work with experienced and effective supervision, sufficient workers, sufficient equipment, or sufficient materials to assure the prompt completion of the contract (i.e., the Contractor is declared delinquent), or performs the Work unsuitably, or neglects or refuses to remove materials or to perform anew such Work as may be rejected as unacceptable and unsuitable, or discontinues the prosecution of the Work, or fails to resume Work which has been discontinued, or becomes insolvent or is declared bankrupt, or files for reorganization under the bankruptcy code, or commits any act of bankruptcy or insolvency, either voluntarily or involuntarily, or allows any final judgment to stand against them unsatisfied for a period of 10 calendar days, or makes an assignment for the benefit of creditors, or fails to comply with contract requirements regarding minimum wage payments, E.E.O. or JSEB requirements, or for any other cause whatsoever fails to carry on the Work in an acceptable manner, or if the Surety executing the bond for any reasonable cause becomes unsatisfactory in the opinion of the Owner, the Owner will give notice in writing to the Contractor and its Surety of such delay, neglect, delinquency or default.
- b. If the Contractor, within a period of 10 calendar days after written notice of default from the Owner delivered to the Contractor's representative on the jobsite, or by facsimile transmission and confirmed by certified mail, does not proceed to correct the conditions of which complaint is made, the Owner shall, upon written notification from its Project Manager of such delay, neglect, or default and the Contractor's failure to correct such conditions, have full power and authority without breaching the contract to take the prosecution of the Work out of the hands of the Contractor and to declare the contract in default and make demands upon the Surety consistent with the rights set forth in the Performance Bond attached herein.
- c. The Owner may, after written notice to the Contractor, terminate the contract or a portion thereof for just cause such as default or for other reasons which are determined to be in the interest of the Owner. Such reasons for termination may include but are not necessarily limited to national defense or national emergency which creates a serious shortage of materials, orders from duly constituted authorities relating to energy conservation, and restraining order or injunctions obtained by third-party

SECTION III.: CHANGES AND DISPUTES (... Continued)

citizen action resulting from national or local environmental protection laws or where the issuance of such order or injunction is primarily caused by acts or omissions of persons or agencies other than the Contractor and unacceptable interference with Operations.

- d. When a contract or any portion thereof is terminated before completion of all items of Work in the contract, payment will be made for the actual number of units or items of Work completed at the contract unit price, or as mutually agreed for items of Work partially completed or not started. No claim for loss of anticipated profits shall be allowed and are specifically waived by Contractor.
- e. Reimbursement for mobilization expenses (when not otherwise included in the contract) including moving equipment to the job will be considered where the volume of Work completed is too small to compensate the Contractor for these expenses under the contract unit prices; the intent being that an equitable settlement will be made with the Contractor.
- f. Acceptable materials procured by the Contractor for the Work that have been inspected, tested, and approved by the Owner, and that are not incorporated in the Work may be purchased from the Contractor at actual cost as shown by receipted bills and actual cost records at such points of delivery as may be designated by the Project Manager.
- g. Termination of a contract or a portion thereof under the provisions of this sub-article shall not relieve the Contractor of its responsibilities for the completed portion, nor shall it relieve its Surety of its obligation for and concerning any claims arising out of the Work performed.
- h. JAXPORT shall have the absolute right to terminate in whole or part the Contract, with or without cause, at any time after Award upon written notification of such termination.

In the event of termination for convenience, JAXPORT will pay the Company for all disbursements and expenses that the Company has incurred, or those for which it becomes obligated prior to receiving JAXPORT's notice of termination. JAXPORT will also pay the Company costs incurred less the reasonable resale value, of materials or equipment that the Company has already ordered, obtained or fabricated in connection with the Contract.

Upon receipt of such notice of termination, the Company shall stop the performance of the Work hereunder except as may be necessary to carry out such termination and take any other action toward termination of the Work that JAXPORT may reasonably request, including all reasonable efforts to provide for a prompt and efficient transition as directed by JAXPORT.

JAXPORT will have no liability to the Company for any cause whatsoever arising out of, or in connection with, termination including, but not limited to, lost profits, lost opportunities, resulting change in business condition, except as expressly stated within these Contract Documents.

SECTION III.: CHANGES AND DISPUTES (... Continued)

6. Delays and Extensions of Time

In the event that the Contractor, in the performance of the Work, encounters inefficiencies, disruptions, or delays as a result of the partial suspension or resequencing of work thereof, or incidental interference therewith by the Owner or its other contractors, or as a result of other unforeseeable causes beyond the control and without fault or negligence of the Contractor such as, but not limited to, Acts of God, fire, flood, war, governmental priority controls, railcar shortages, general strikes, and labor work stoppages, the Contractor shall notify the Owner in writing within 5 calendar days of the commencement of the delay that he intends to request additional time for contract completion. Such requests for additional time shall be decided by the Owner within 5 working days of receipt of notification and if a time extension is approved, it shall be authorized by Change Order. In the event of a continuing delay having a single cause, notification as above is required, however, a determination by the Owner as to time extension allowed will not be made until the Contractor has submitted electronically in E-Builder complete facts as to the reason and total extent of the delay, including such documentation as may be reasonably required by the Owner. No time extension shall be granted for delays occurring more than 5 calendar days before written notification is made to the Owner, and no time extension shall be granted for any delay caused or occasioned by fault, negligence, omission, or failure to timely prosecute the Work, including procurement delays on the part of the Contractor, its agents, suppliers, employees, or subcontractors. The Contractor shall also take immediate action upon incurring such delay to minimize the effects of that delay. The allowability and length of any such time extension shall be determined in writing. In making that determination, no extension of time will be allowed the Contractor for delays encountered in one or more phases of the Work that can be overcome by reasonable readjustments of the Contractor's planned progress on other phases of the Work. Only critical path delays will be recognized for an extension of time. All requests for an equitable time extension shall be accompanied with a time impact analysis.

- a. Time extensions may also be allowed on the same terms and conditions as set forth above, in the event that the Contractor over the course of the Work encounters unusually adverse weather in excess of the norm for the locality. The Contractor expressly agrees that in undertaking to complete the Work within the time specified, it has made allowance for all hindrances including adverse weather and delays which might normally be expected to occur in performing the Work. No claims shall be made for money by the Contractor for such hindrances and delays.
- b. The Contractor's sole and exclusive remedy for delays and inefficiencies as described herein shall be an equitable extension of time. The Contractor shall not be entitled to any additional compensation or payment for extra costs or damages incurred by them due to hindrances of, or delays to, the progress of the Work. Any claim related to delay shall be in writing and include a time impact analysis.
- c. No extensions of time will be granted due to Contractor's failure to protect

SECTION III.: CHANGES AND DISPUTES (... Continued)

the site, materials, or working conditions from adverse weather conditions including, but not limited to site drainage, storage, and temporary enclosures as needed.

- d. No extensions of time will be granted due to Contractor's failure to diligently prosecute the contract, including, but not limited to, procurement delays.
- e. Under no circumstances shall any claim for additional costs be accepted based upon a hypothetical formula, Means or other estimated costs. All claims shall be presented utilizing discrete data evidencing direct costs to project.
- f. Contractor waives any claims for attorney fees and claims consultant costs.

7. Disputes

Except as otherwise provided in this contract, any dispute concerning a question of fact arising under this contract which is not disposed of by agreement with the Project Manager shall be decided by appeal to the Chief Executive Officer of JAXPORT. The Chief Executive Officer shall, within 30 days of receipt of the written appeal, reduce its decision to writing, and mail or otherwise deliver a copy to the Contractor. The 30-day period may be extended in 30-day increments by written order of the Chief Executive Officer, or its designee, when and if it determines that additional studies or investigations are necessary to render a decision. This decision shall be final and conclusive, unless within 30 days after receipt thereof by the Contractor, the Contractor mails or otherwise delivers to the Chief Executive Officer a written appeal addressed to the Chairman of JAXPORT. In connection with the appeal proceeding under this clause, the Contractor shall be given an opportunity to be heard and to offer supportive evidence to its appeal. Pending final decision on the dispute should the project be ongoing, the Contractor shall proceed diligently with the performance of the contract in accordance with the Chief Executive Officer's decision. The decision on the appeal shall be rendered by JAXPORT's Governing Body and shall be final and conclusive unless determined by subsequent judicial review to have been fraudulent, capricious, so grossly erroneous as to imply bad faith, or not supported by any substantial evidence.

Compliance with this process shall be a condition precedent before any litigation can be brought to appeal any decision.

8. Recovery Rights, Subsequent to Final Payment

The Owner reserves the right should an error be discovered in the partial or final Applications for Payment, or should proof of defective Work or materials used by or on the part of the Contractor be discovered after the final payment has been made to claim and recover from the Contractor or its Surety, or both, by process of law, such sums as may be sufficient to correct the error or make good the defects, errors, or omissions in the Work and materials.

SECTION III.: CHANGES AND DISPUTES (... Continued)

All records pertaining to the Project shall be retained by the Contractor for a period of three years from the date of final acceptance of the Project, unless additional time for retention is requested in writing by the Owner. Upon request, all such records shall be made available to the Owner or its representative. For the purpose of this Section, records shall include all books of account, supporting documents, both paper and electronic, and papers deemed necessary by the Owner to assure compliance with the contract provisions, photographs, videos, video tapes and project pictures stored electronically. Contractor shall reasonably cooperate with the Owner in obtaining and reviewing all documentation herein.

GENERAL CONDITIONS

SECTION IV.: ADMINISTRATIVE

1. "As-built" Drawings and Equipment Manuals

- a. At the completion of the Work under this contract, the Contractor shall prepare and deliver electronically in E-Builder to the Owner one complete set of the construction drawings indicating As-built conditions. Final As-built drawings submissions shall consist of:

- (1) Adobe Acrobat format (.pdf) – 1 complete set
- (2) AutoCAD Map 3D 2014 format (.dwg) to include external references

Final payment shall be withheld from the Contractor until acceptable "As-built" drawings are furnished to the Owner.

- b. The Contractor shall furnish electronically in E-Builder a complete set of operations and maintenance instructions together with the repair parts lists for all mechanical and electrical equipment. Those instructions shall be prepared and published by the manufacturer, and shall be delivered to the Owner prior to the final inspection. Final payment shall be withheld from the Contractor until such documents are furnished to the Owner.

2. Conferences

- a. Unless waived by agreement of both parties, a Preconstruction Conference will be held at a mutually convenient time as soon as is practicable following award of this contract; normally, within 21 calendar days thereafter. The Preconstruction Conference shall be attended by responsible representatives of the Owner, and the Contractor and its subcontractors. The Contractor, its subcontractors and its suppliers are expected to be fully familiar with the contract documents and specific Project requirements by the time set for the Preconstruction Conference and the Owner may reasonably presume such notwithstanding paragraph "c" of the "Contract Documents" Section I of these General Conditions. The Contractor shall then present for discussion at the meeting any questions, concerns, discrepancies, need for clarifications and any other significant issues which may in any manner affect the project schedule or its performance of the Work for these issues discussed after the award of contract. Written clarifications and/or interpretations of the contract documents shall be furnished to the Contractor without unreasonable delay. Written "Minutes" of the Preconstruction Conference will be prepared by the Owner, with copies provided to all attendees and which the "Minutes" shall be retained.

The Contractor shall deliver to the Owner at the Preconstruction Conference the specified copies of:

- Schedule of Values (where applicable).
- Quality control program.

SECTION IV.: ADMINISTRATIVE (... Continued)

- List of project subcontractors.
 - List of Contractor's project management team with telephone numbers.
 - Identification of major suppliers and/or manufacturers to be used on the project.
 - Schedule for, and listing of, shop drawing submittals.
 - Other documents as may be required elsewhere in these specifications.
- b. The Contractor or Owner may request conferences for other useful purposes at convenient times throughout the contract period. Representatives of all concerned parties shall receive reasonable notice of any such meeting.

3. Payments

Unless otherwise specified in the section of "Special Conditions" and upon receipt electronically in E-Builder of Contractor's Application for Payment (Forms AFP-1 and AFP-2), payment for this Work will be made as follows:

- c. Payment will be made once each month in the amount of 95 percent of the value of completed Work, based on contract prices of labor and materials incorporated in the Work and of materials suitably stored at the site thereof for incorporation in the Work, as estimated or approved by the Owner's representative less the aggregate of previous payments. At such time as the Work is substantially complete and is available for beneficial use/occupancy, the Project Manager may, at his/her discretion, release the retainage, except that a sufficient amount may be withheld to cover the cost of any claims by the Owner, incomplete items, until final settlement of the contract. Final payment, including retainage will be made after closeout of the Work has been satisfactorily completed and all requirements of the contract documents have been fulfilled.
- d. The Contractor shall submit electronically in E-Builder to the Project Manager a proposed Schedule of Values of the various portions of the Work, including line item quantities aggregating to the total contract sum, through E-Builder and prior to the Preconstruction Conference. This schedule, when approved by the Project Manager, shall be used as a basis for the Contractor's application for payments. The Contractor shall update this schedule each time a Change Order affecting the contract total price is approved. The contract price will be adjusted to provide payment for the actual quantities of unit price items as they are completed and accepted. The following items are required with each AFP:
- (1) Form AFP-1 Application for Payment
 - (2) Form AFP-2 Schedule of Values
 - (3) Progress Schedule
 - (4) JSEB Form 5

SECTION IV.: ADMINISTRATIVE (... Continued)

(5) Narrative Report that addresses:

Work Performed

Work Planned

Problems

Open Issues

(6) Photographs (See Section SC, Item 11 for detailed requirements.)

e. Payments may be withheld for failure of the Contractor to comply with the provisions of the contract documents, including but not limited to:

- (1) Defective work not remedied.
- (2) Failure of the Contractor to make payments properly to subcontractors or for labor, materials, or equipment.
- (3) Any delay or damage to another Contractor, upon certification by injured Contractor, of the cause and amount of any said damage.
- (4) Unsatisfactory prosecution of the Work by the Contractor.

Payments may also be withheld if claims have been filed or there is reasonable evidence indicating the probable filing thereof, or if Contractor's Surety for this Project so requests in writing.

Withholding of payments is a remedy in addition to all other remedies available to the Owner. Where pursuant to condition (2) of this paragraph, a contractor certifies to the Owner the necessity to withhold progress payments to another contractor, the certifying contractor shall defend, indemnify, and hold harmless the Owner from any and all claims or suits arising from such action, which is discretionary with the Owner.

- f. Whenever Mobilization and Demobilization are a part of the bid items, Mobilization will account for and be paid out at sixty percent (60%) and Demobilization will account for and be paid out at forty percent (40%).
- g. Whenever any change or combination of changes in the Work results in an increase or decrease in the original estimated contract quantities, and the Work added or eliminated is of the same general character as that shown on the original plans, the Contractor shall accept payment in full at the original contract unit prices for the actual quantities of work done, and no allowance will be made for any loss of anticipated profits because of increases or decreases in quantities provided, however, that any increased or decreased work covered by a Change Order shall be paid for as stipulated therein.
- h. Final payment shall not be made until the Contractor has delivered to the Owner any required submittals, the Certificate of Contract Completion (Form FCC); Consent of Surety to Final Payment (Form CONSUR), including valid Power of Attorney, and JSEB Form 5.
- i. No payment by the Owner shall be construed to be acceptance of defective Work or improper materials. Contractor warrants and guarantees that title to

SECTION IV.: ADMINISTRATIVE (... Continued)

all work, materials, and equipment covered by any Application for Payment, whether incorporated into the Project or not will pass to the Owner at time of final payment, free and clear of all liens, claims, security interests and encumbrances.

- j. Payments will be made within 20 business days after receipt of Contractor's properly documented invoice(s), unless returned for correction of invoice(s), or submission of additional substantiation.
- k. The acceptance of final payment shall constitute a waiver of all claims by the Contractor except those specifically preserved according to the provisions of these contract documents.
- l. The Owner may at any time have access to the Contractor's records for the purpose of auditing the financial and contractual performance of the Contractor. The Owner may obtain copies of all financial and scheduling computer disks at any time from the Contractor, and shall have reasonable access to all other documents except those that would be privileged under Florida law. The Owner may audit the financial records of the Contractor at any reasonable time, at its own expense.

4. Progress Schedule

The Contractor shall prepare for the Owner's approval a progress schedule for the Project showing the dates for the starting and completion of the various items of construction. The schedule shall be prepared in Microsoft Project (or equivalent) format, unless the Technical Specifications provide for a more detailed progress schedule.

Four (4) copies shall be furnished to the Owner's representative at the Preconstruction Conference. This schedule, after approval, shall be used by the Owner as the primary means of determining satisfactory execution of the Work by the Contractor. No payments will be made to the Contractor until the schedule is approved. All proposed Change Orders will include a revised schedule.

Should the Contractor fall behind the approved schedule, it shall provide a recovery schedule and be required to revise methods or operations, increase its forces (labor and equipment), work extra hours per day, and/or work extra days per week as necessary until the scheduled progress is acceptable, at no extra compensation by the Owner. Failure on the part of the Contractor to take necessary and sufficient actions in this regard and to put the Project back on schedule within a reasonable time, not to exceed 30 calendar days after notification by the Owner of such delinquency, shall be considered sufficient grounds for termination of the contract. The decision by the Owner not to terminate shall not constitute a waiver or preclude the termination for default as appropriate.

Any delays encountered during the construction which may be excusable under the provisions of these "General Conditions" shall be brought to the Project Manager's attention in accordance with the provisions. The approved Project

SECTION IV.: ADMINISTRATIVE (... Continued)

schedule may, depending on the Project Manager's decision, be adjusted accordingly.

GENERAL CONDITIONS

SECTION V.: INSURANCE AND BOND

1. Insurance and Indemnification.

- a. The Contractor shall not commence Work until the Contractor has procured the insurance required under this Section and such insurance has been approved by the Owner. The Contractor shall provide evidence of such insurance in the following manner:
 - (1) Contractor agrees, at its sole expense, to maintain on a primary, non-contributory basis during the life of this Contract or performance of Work hereunder, insurance coverages, limits, and endorsements unless otherwise noted herein. Contractor agrees to provide evidence of Commercial General Liability, Contractor's Professional Errors and Omissions Liability and Commercial Umbrella/Excess Liability coverages at execution of the Contract. The other coverages required herein for Business Auto Liability, Contractor's Pollution Legal Liability, Inland Marine Builder's Risk Insurance, and Workers' Compensation. In the event the Contractor performs any site work, other than testing, then all insurance required herein will need to be evidenced prior to commencement of said site work.
 - (2) The Contractor agrees the insurance requirements herein as well as JAXPORT's review or acknowledgement, is not intended to and shall not in any manner limit or qualify the liabilities and obligations assumed by the Contractor under this Contract.
 - (3) As evidence of compliance with the insurance required by Paragraph "c.", Subparagraphs 1 (Workers' Compensation/Employers' Liability), 2 (Commercial General Liability) and 3 (Business Auto) below, the Contractor shall furnish the Owner with a Certificate of Insurance Compliance (Form 101-87) signed by an authorized representative of the insurer(s) providing the coverage. The specified form must be used; no substitutions will be permitted.
 - (4) As evidence of compliance with the insurance required by Paragraph "c.", Subparagraph 4 (Protection for Owner) below, the Contractor shall furnish the Owner with either the original of the Owner's and Contractor's Protection Liability Policy(ies) or a Certificate of Insurance Compliance (Form 101-87) signed by an authorized representative of the insurer(s) verifying inclusion of the Additional Insured endorsement in the Commercial General Liability Coverage.
 - (5) If this contract includes construction of, or additions to aboveground buildings or structures, or the installation of machinery or equipment into an existing structure as evidence of compliance with the insurance required by Paragraph "c.", Subparagraph 5 (property insurance) below, the Contractor shall furnish the Owner with the original of the policy or policies of insurance required and a Certificate of Insurance Compliance (Form 101-87) signed by an authorized representative of

SECTION V.: INSURANCE AND BOND (... Continued)

the insurer(s).

- (6) With respect only to the insurance required by Paragraph "c.", Subparagraph 4 (Protection for Owner) and Subparagraph 5 (property insurance) below, and then only for a maximum of sixty (60) days from the date of inception of the policy or policies in lieu of the original of any required policy or policies of insurance, the Contractor may furnish an original binder or binders of the insurance signed by an authorized representative of the insurer(s) and a Certificate of Insurance Compliance (Form 101-87) signed by an authorized representative of the insurer(s).
 - (7) Until such time as the insurance is no longer required to be maintained by the Contractor, the Contractor shall provide the Owner with renewal or replacement evidence of the insurance in the manner described by Paragraph "a.", Subparagraphs 1, 2, 3 and 4 below, no less than thirty (30) days before the expiration or replacement of the insurance for which previous evidence of insurance has been provided.
 - (8) Neither approval by the Owner for failure to disapprove the insurance furnished by the Contractor shall relieve the Contractor of the Contractor's full responsibility to provide the insurance as required by this contract.
- b. Insurers providing the insurance required by this contract must meet the following minimum requirements:
- (1) Such insurers must be licensed to write insurance of the required class(es) in the State of Florida, either: a) authorized by subsisting certificates of authority issued to the companies by the Department of Insurance of the State of Florida, or b) with respect only to the coverage required by Paragraph "c.", Subparagraph 1 (Workers' Compensation/Employers Liability) authorized as a group self-insurer pursuant to Florida Statutes 440.57.
 - (2) In addition, such insurers other than those authorized by Florida Statutes 440.57 shall have and maintain throughout the period for which coverage is required a Best's Rating of "A-" or better and a Financial Size Category of "VII" or better according to A. M. Best Company.
 - (3) If, during the period when an insurer is providing the insurance required by this contract, an insurer shall fail to comply with the foregoing minimum requirements, as soon as the Contractor has knowledge of any such failure, the Contractor shall immediately notify the Owner and immediately replace the insurance provided by the insurer, with an insurer meeting the requirements. Until the Contractor has replaced the unacceptable insurer with an insurer acceptable to the Owner, the Contractor shall be in default of this contract.
- c. Without limiting any of the other obligations or liabilities of the Contractor,

SECTION V.: INSURANCE AND BOND (... Continued)

the Contractor shall, at the Contractor's sole expense, procure, maintain and keep in force the amounts and types of insurance conforming to the minimum requirements set forth in this Paragraph "c." Except as otherwise specified in this contract, the insurance shall commence prior to the commencement of work by the Contractor and shall be maintained in force until the contract completion date.

(1) Workers' Compensation/Employers' Liability:

- (a) The Contractor's insurance shall cover the Contractor and its subcontractors of every tier for those sources of liability which would be covered by the latest edition of the standard Workers' Compensation Policy, as filed for use in Florida by the National Council on Compensation Insurance, without restrictive endorsements. In addition to coverage for the Florida Workers' Compensation Act, where appropriate, coverage is to be included for the Longshoremen's and Harbor Workers' Compensation Act, Maritime, including Jones Act, Federal Employers' Liability Act and any other applicable Federal or State laws.

NOTE: If the project is to be accomplished on the face of the wharf, the concrete area where crane rails are located to the edge of the wharf and underneath the wharf (piling, deck repairs, etc.), Longshoremen's and Harbor Workers' Compensation will be required.

- (b) Subject to the restrictions of coverage found in the standard Workers' Compensation Policy, there shall be no maximum limit on the amount of coverage for liability imposed by the Florida Workers' Compensation Act, the Longshoremen's and Harbor Workers' Compensation Act, or any other coverage customarily insured under Part One of the standard Workers' Compensation Policy. The minimum amount of coverage for those coverage's customarily insured under Part Two of the standard Workers' Compensation (inclusive of any amounts provided by an umbrella or excess policy) shall be those amounts stated in Required Limits of Insurance (Form 100-87).

(2) Commercial General Liability:

The Owner shall be named an additional insured on the CGL Policy as well as Umbrella and or Excess policy or policies. The Owner shall not be responsible to pay any deductible sum. This is not meant to extend the Owner's liability beyond Section 768.28, Florida Statutes.

- (a) The Contractor's insurance shall cover the Contractor for those sources of liability which would be covered by the latest occurrence form edition of the standard Commercial General Liability Coverage Form (ISO Form CG 2010 07 04 or GC 2010 04 13 Additional Insured – Owners, Lessees, or Contractors-

SECTION V.: INSURANCE AND BOND (... Continued)

Schedule Persons or Organization, in combination with the GC 2037 10 01) or similar endorsements providing equal or broader Additional Insured Coverage. Commercial General Liability must be filed for use in the State of Florida by the Insurance Services Office, without the attachment of restrictive endorsements other than the elimination of Coverage C., Medical Payments and the elimination of coverage for Fire Damage Legal Liability.

- (b) If the contract value of this Project exceeds \$100,000, the Contractor shall maintain separate limits of coverage applicable only to the work performed under this contract. The minimum limits to be maintained by the Contractor (inclusive of any amounts provided by an umbrella or excess policy) shall be those that would be provided with the attachment of the Amendment of Limits of Insurance (designated Project or Premises) endorsement (ISO Form CG 25 01) to a Commercial General Liability Policy with the minimum amounts stated in the Required Limits of Insurance (Form 100-87).
 - (c) The Contractor shall continue to maintain Products/Completed Operations Coverage for a period of three (3) years after the contract completion date. The insurance shall cover those sources of liability which would be covered by the latest occurrence form edition of Coverage A of the Commercial General Liability Form (ISO Form CG 00 01) or Coverage A of the occurrence form Products/Completed Operations Liability Coverage Form (ISO Form CG 00 37), as filed for use in the State of Florida by the Insurance Services Office, without restrictive endorsements. The minimum limits to be maintained by the Contractor (inclusive of any amounts provided by an umbrella or excess policy) shall be the amounts stated in the Required Limits of Insurance (Form 100-87).
 - (d) Contractor agrees it's coverage will not contain any restrictive endorsement(s) excluding or limiting Products/Completed Operations, Independent Contractors, Broad Form Property Damage, X-C-U Coverage, Contractual Liability, Cross Liability or Separation of Insured's. The Contractor agrees that any self-Insured Retention or deductible shall not exceed \$25,000.
- (3) Business Auto Policy:
- (a) The Contractor's insurance shall cover the Contractor for those sources of liability which would be covered by Part IV of the latest occurrence edition of the standard Business Auto Policy (ISO Form CA 00 01), including coverage for liability contractually assumed, as filed for use in the State of Florida by the Insurance Services Office, without the attachment of restrictive endorsements. Coverage shall include owned, non-owned and hired autos.

SECTION V.: INSURANCE AND BOND (... Continued)

- (b) The minimum limits to be maintained by the Contractor (inclusive of any amounts provided by an umbrella or excess policy) shall be the amounts stated in the Required Limits of Insurance (Form 100-87).
- (4) Protection for Owner Coverage:
 - (a) The Contractor shall provide the Owner with an Owner's and Contractor's Protective Liability Policy (OCP Policy). If the Contractor is unable to procure the minimum amounts of insurance in a single policy, the Contractor may provide the minimum limits through a combination of a primary OCP policy and one or more excess policies. The policy or policies shall cover the Owner for all sources of liability which would be covered by the latest occurrence edition of the standard Owner's and Contractor's Protective Liability Coverage Form, Coverage for Operations of Designated Contractor (ISO Form CG 00 09), as filed for use in the State of Florida by the Insurance Services Office, without the attachment of restrictive endorsements.
 - (b) The Owner shall also be a named an unconditional insured on the OCP Policy and, if applicable, the excess policy or policies. This coverage extends to any act or omission by the Owner, its employees, directors, and agents related to this project. The policy or policies shall be endorsed to include the Owner's officials, officers, agents and employees as insured's. The policy or policies shall include the Contractor and the Contractor's subcontractors of every tier as the contractor designated in the declarations. The coverage is not meant to waive any limits set by Section 768.28, Florida Statutes.
 - (c) The minimum OCP Policy limits per occurrence and if subject to an aggregate, annual aggregate to be provided by the Contractor (inclusive of any amounts provided by excess policies) shall be the same as the amounts shown in the Required Limits of Insurance (Form 100-87) as the minimum per occurrence and general policy aggregate limits respectively required for the Commercial General Liability Coverage. The limits afforded by the OCP Policy and any excess policies shall apply only to the Owner and the Owner's officials, officers, agents and employees and only to claims arising out of, or in connection with, the Work under this contract.
 - (d) The OCP Policy and, if applicable, the excess policy or policies, must be specifically endorsed to provide the Owner with 45 days' written notice of cancellation, non-renewal or restriction.
 - (e) As an alternative to the OCP policy, the Contractor may include the Owner and the Owner's officials, officers, agents, consultants and employees as Additional Insured's on the Commercial General Liability Coverage required pursuant to Subparagraph

SECTION V.: INSURANCE AND BOND (... Continued)

"c.2". If the Additional Insured alternative is selected, the coverage afforded such Additional Insured's shall be no more restrictive than that which would be afforded by adding the Owner and the Owner's officials, officers, agents, consultants and employees as Additional Insured's using the latest Additional Insured - Owners, Lessees or Contractors (Form B) endorsement (ISO Form CG 2010). Certificate of Insurance Compliance shall be clearly marked to reflect use of this alternative.

- (5) Property Insurance:
- (a) If the contract includes construction of, or additions to aboveground buildings or structures, Contractor shall provide all risk Builder's Risk Insurance on a form which is no more restrictive than that afforded by the latest editions of Insurance Services Office Forms CP 00 20 and CP 10 30. If the contract does not include construction of, or additions to aboveground buildings or structures but does involve the installation of machinery or equipment, Contractor shall provide an all risk installation Floater including installation and transit.
 - (b) For Builder's Risk, the amount of insurance is to be 100 percent of the completed value of such addition(s), building(s) or structure(s). For Installation Floater, the amount of insurance is to be 100 percent of the installed replacement cost value. For Builder's Risk, the recovery shall be based on completed replacement cost. For Installation Floater, the recovery shall be based on the installed replacement cost.
 - (c) The Builder's Risk Policy must be specifically endorsed to eliminate any "occupancy clause" or similar warranty or representation that the building(s), addition(s) or structure(s) in the course of construction shall not be occupied without specific endorsement of the policy. The policy must be endorsed to provide that, subject to the notice of cancellation requirement, the Builder's Risk coverage will continue to apply until final acceptance of the building(s), addition(s) or structure(s) by the Owner. The Installation Floater Policy must be specifically endorsed to provide that, subject to the notice of cancellation requirement, the policy shall remain in force until final acceptance of the machinery or equipment by the Owner.
 - (d) The maximum deductible shall be \$5,000.00 per occurrence.
 - (e) The Owner must be included as a named insured for any liability arisen from its acts relating to the project.
 - (f) The policy must be specifically endorsed to provide the Owner with 45 days' written notice of cancellation, non-renewal or restriction.
 - (g) If the contract includes construction of, or additions to,

SECTION V.: INSURANCE AND BOND (... Continued)

aboveground buildings or structures which are located in a special flood hazard area as defined by the National Flood Insurance Program, flood insurance must be afforded for the lesser of the total insurable value of such buildings or structures, the maximum amount of flood insurance coverage available under the National Flood Program or, the total compensation due Contractor under the contract. If the contract does not include construction of, or additions to, aboveground buildings or structures but does include the installation of machinery or equipment in a building or structure which is located in a special flood hazard area as defined by the National Flood Insurance Program, flood insurance must be afforded for the lesser of the total insurable value of the machinery or equipment or the maximum amount of flood insurance coverage available under the National Flood Program.

- d. The insurance provided by Contractor pursuant to this contract shall apply on a primary basis and any other insurance or self-insurance maintained by the Owner or an Owner's official, officer, agent or employee shall be excess of and not contributing with the insurance provided by or on behalf of the Contractor.
- e. Except with respect to the Property Insurance, the coverage maintained by the Contractor shall apply on a first dollar basis without application of a deductible or self-insured retention.
- f. Compliance with the insurance requirements of this contract shall not limit the liability of the Contractor, its subcontractors, employees, or agents to the Owner or others. Any remedy provided to the Owner or the Owner's officials, officers, agents and employees by the insurance shall be in addition to and not in lieu of any other remedy available under this contract or otherwise.
- g. Indemnification.
 - (1) The Contractor shall indemnify, defend and hold harmless the JPA, its employees and elected officials, from all liabilities, damages, losses, costs and expenses of whatsoever kind or nature, including, but not limited to, reasonable attorney's fees, reasonable expert witness fees and court costs (all of which are collectively referred to as "Damages") to the extent such Damages are caused by the negligence, recklessness or intentional wrongful conduct of the Contractor and/or persons employed or utilized by the Contractor in the performance of this Agreement.
 - (2) In any and all claims against the Owner or its members, directors, officers, employees, representatives and agents by any employee of the Contractor, any subcontractor, anyone directly or indirectly employed by any of them or anyone for whose acts any of them may be liable, this indemnification under this Sub-article "g." shall not be

SECTION V.: INSURANCE AND BOND (... Continued)

limited in any way by any limitation on the amount or type of damages, compensation or benefits payable by or for the Contractor or any subcontractor under workers' compensation acts, disability benefit acts or other employee benefit acts.

- (3) In addition to those indemnities previously described, the obligations of the Contractor under this Sub-article "g." shall extend to the liability of the Consultant or Consultants, if any, on this Project, and the Consultant's members, directors, officers, employees, representatives or agents in the same manner as applicable to the Owner. Provided, however, the obligations of the Contractor under this Sub-article "g." shall not extend to the liability of the Consultant, its members, directors, officers, employees, representatives or agents arising out of: 1) the preparation or approval of maps, drawings, opinions, reports, surveys, change orders, designs or specifications, or 2) the giving of or the failure to give directions or instructions by the Consultant, its members, directors, employees, representatives or agents provided such giving or failure to give is the primary cause of the injury or damage.
 - (4) The remedy provided to the Owner and the Consultant and their respective members, directors, officers, employees, representatives and agents by this indemnification shall be in addition to and not in lieu of any other remedy available under this contract or otherwise. This indemnification obligation shall not be diminished or limited in any way to the total limits of insurance required in this contract or otherwise available to Contractor or any sub-contractor.
 - (5) To the fullest extent permitted by law, the Contractor shall indemnify, defend and hold harmless the Owner its officers, agents, volunteers, and employees from and against all claims, damages, losses, and expenses, including but not limited to all fees and charges of engineer(s), architect(s), attorney(s) and other professional(s), court costs, or other alternative dispute resolution costs arising out of, resulting from, or otherwise but for the performance or furnishing of Proposer's work or services under this Invitation to Bid; provided that any such claim, damage, loss or expense is attributable to bodily injury, sickness, disease, death or personal injury, or property damage, including the loss of use or diminution in value resulting there from; but only to the extent caused in whole or in part by the actual or alleged negligent acts, errors, or omissions of Contractor, Contractor's Subcontractor(s) or anyone directly or indirectly employed or hired by Contractor, or anyone for whose acts Contractor may be liable. The Owner reserves the right, but not the obligation, to participate in defense without relieving Contractor of any obligation hereunder.
- h. Contractor's Pollution Liability
- (1) As evidence of compliance with the insurance required by Paragraph "c.", Subparagraphs 6 (Contractor's Pollution Liability), the Contractor

SECTION V.: INSURANCE AND BOND (... Continued)

shall furnish the Owner with a Certificate of Insurance Compliance (Form 101-87) signed by an authorized representative of the insurer(s) providing the coverage. The Contractor agrees the policy shall include a minimum three (3) year Discovery (tail) reporting period, and a retroactive date that equals or precedes the effective date of the Contract, or the performance if Work hereunder. This coverage can be provided on a Per-Project basis.

2. Surety Bonds.

- a. General. All bonds shall be written through a reputable and responsible Surety bond agency licensed to do business in the State of Florida and with a Surety company or corporation meeting both Subparagraphs (1) and (2) below. All bonds, including bid bonds and contract bonds shall have affixed to them a certified copy of current Power of Attorney of the Attorney-in-Fact who executed the bond on behalf of the Surety. Bond requirements in excess of \$500,000, including bid bonds and contract bonds, shall be written with a Surety company meeting the specifications of both Subparagraphs (1) and (2). In the event the bond requirement does not exceed \$500,000, bonds written with a Surety company meeting either a) the requirements of Subparagraphs (1) and (2) or, alternatively, b) the requirements of Subparagraph (3) shall be acceptable.

- (1) Having a minimum rating in the latest revision of Best's Insurance Reports of:

Contract Amount	Policyholder	Financial
Under \$250,000	B+	Class III
\$250,000.01 to \$2,500,000	B+	Class IV
\$2,500,000.01 to \$5,000,000	A-	Class IV
Over \$5,000,000.01	A	Class V

- (2) Holding a current certificate of authority as acceptable Surety on federal bonds in accordance with U. S. Department of Treasury, Circular 570, current revision. If the amount of the bond exceeds the underwriting limitations set forth in the Circular, in order to qualify, the net retention of the Surety Company shall not exceed the underwriting limitation in the Circular and the excess risk must be protected by co-insurance, reinsurance, or other methods. Further, the Surety Company shall provide the Owner with evidence satisfactory to the Owner that such excess risk has been protected in an acceptable manner.
- (3) In the event the bond requirement does not exceed \$500,000, bonds

SECTION V.: INSURANCE AND BOND (... Continued)

with a Surety Company in compliance with the following requirements shall be acceptable:

- (a) The Surety Company holds a certificate of authority authorizing it to write Surety bonds in Florida.
- (b) The Surety Company has twice the minimum surplus and capital required by the Florida Insurance Code at the time the invitation to bid is issued.
- (c) The Surety Company is otherwise in compliance with the provisions of the Florida Insurance Code.
- (d) The Surety Company holds a currently valid certificate of authority issued by the United States Department of the Treasury under Section 9304 to 9308 of Title 31 of the United States Code.

In order to qualify as an acceptable Surety Company under this Subparagraph (3), a Certificate and Affidavit for Surety Bond Insurer (Form CASBI included in the contract documents) shall be executed by an officer of the Surety bond insurer as evidence that a Surety Company is in compliance with the foregoing requirements and shall be submitted with the bond.

- b. Agent. The name of the agent for the Surety Company shall be listed in the prescribed space on both the bid bond and the contract bond.
- c. Bid Bonds. Refer to "Supplemental Instructions to Bidders," Article 6 "Bid Guaranty." Provisions of this Article apply to bid bonds. Surety's standard bond form for State of Florida is acceptable.
- d. Contract Bonds. The Contractor, at its own expense, shall furnish a Performance Bond, and a Statutory Payment Bond as security for the faithful performance under the contract documents. The bonds shall be in an amount at least equal to the contract price, in the form provided in these contract documents, and with such Surety as is acceptable to the Owner. Such bonds shall indemnify the Owner for damages associated with unexcused late delay of the project.
- e. Additional Bond. It is further mutually agreed between the parties hereto that if, at any time during the contract period, the Surety or Sureties upon the bonds ceases to meet the specified minimum criteria or otherwise become financially unsatisfactory, or if for any reason, such bond ceases to be adequate to cover the performance of the Work, the Contractor shall immediately, and at its expense, furnish an additional bond or replacement bond in such form, amount, and with such Surety or Sureties as shall be satisfactory. In such event, no further payments to the Contractor shall be deemed to be due under this contract until such new or additional security for the faithful performance of the Work shall be furnished in manner and form satisfactory to the Owner.

SPECIAL CONDITIONS

INDEX

ITEM		PAGE NO.
		SC-
1.	Time for Completion	2
2.	Liquidated Damages.....	2
3.	Warranty.....	3
4.	Permits	3
5.	Owner's Minimum Project Work Rules.....	3
6.	Existing Soil Conditions.....	3
7.	Site Conditions.....	3
8.	Structure over Navigable Waters	4
9.	Welding, Burning, and Hot-work Regulations.....	4
10.	Tax Savings Program, General.	5
11.	Progress Photographs.....	8

SPECIAL CONDITIONS

The "General Conditions," Section I through Section V, and the articles of this section shall apply to the Contractor and all Subcontractors. The "Special Conditions" supplement and/or amend the "General Conditions" and other contract documents as necessary for this project. Any article, paragraph, or subparagraph in the "General Conditions" or other contract documents not so supplemented or amended by this section shall remain in effect.

1. Time for Completion

The Contractor shall totally and finally complete all work not later than **180** calendar days after receipt of Notice to Proceed.

2. Liquidated Damages

- a. The parties agree that at the time of entering into this Agreement the parties cannot determine the precise amount of damages that Jaxport will suffer in the event Contractor is unable to perform its obligations under this Agreement. The parties agree that the damages suffered by Jaxport under such circumstances are uncertain and difficult to ascertain. Therefore, the parties agree that this sum is fair and reasonable and represents liquidated damages and is not a penalty.
- b. Should the Contractor or, in case of its default, the Surety fail to complete the work within the time stipulated in the contract, or within such extra time as may have been granted by the Owner, the Contractor or, in case of its default, the Surety shall pay to the Owner not as a penalty but as Liquidated Damages the amount so due as determined below.
- c. For each calendar day that any part of the work remains uncompleted after the expiration of the contract time, the sum per day specified below shall be deducted by the Owner from monies due the Contractor, not as a penalty but as agreed Liquidated Damages representing loss to the Owner for additional cost of contract administration, inconvenience and additional cost of operations only due the Owner as a result of the Contractor's late completion. If no money is due the Contractor, the Owner shall have the right to recover said sum or sums from the Contractor, from the Contractor's Surety, or from both. The assessment of Liquidated Damages shall be in addition to actual damages or claims to the Owner except for inconvenience, administrative costs, and additional costs of operation.
- d. Liquidated Damages for failure to complete the work within the time specified for the completion of the work shall be:

\$1,197 per calendar day
- e. Permitting the Contractor to continue and to finish the work, or any part of it, after the expiration of the contract time allowed including extensions of time granted to the Contractor shall, in no way, act as a waiver on the part of the Owner, of the Liquidated Damages due under the contract.

-
- f. In case of default of the contract and the completion of the work by the Owner, the Contractor and its Surety shall be liable for the Liquidated Damages and delay under the contract, but no Liquidated Damages shall be chargeable for any delay in the final completion of the work by the Owner due to any unreasonable action or delay on the part of the Owner.

3. Warranty

The Contractor agrees to correct or replace any defective materials or workmanship for a period of **One (1) Year** from execution of Certificate of Contract Completion and Contractor's Affidavit to Owner. The Technical Specifications may require a longer warranty period for all or portions of the Work.

4. Permits

The Contractor shall secure permits and licenses as specified in paragraph "f" of the "Contractor's Responsibility" section of the "General Conditions". The Owner will obtain State and Federal permits for permanent construction, and has applied for Federal and State dredge and fill permits and other local permits for this project, if applicable.

The Contractor shall obtain the City Building Permit and any permits required for the construction of temporary structures, and temporary dredging and filling which may be necessary to facilitate its construction scheme and operations.

5. Owner's Minimum Project Work Rules

See FORM PWR

6. Existing Soil Conditions

The Owner has, for its own use, made borings at or near the site of the Work. Any boring data shown in these contract documents is presented only as information which indicates certain conditions found and limited to the exact locations and on the dates indicated. Any interpretations or conclusions drawn by the Contractor from such data shall be its own and the Owner makes no representation or guarantee concerning the accuracy or completeness of such data. The Contractor shall be responsible for making its own determination of subsurface conditions prior to bidding and shall not assume that any of the aforesaid boring data will necessarily be found or maintained.

7. Site Conditions

The Contractor shall visit the location of the Work and make such investigations of existing conditions above or below the surface of the ground as it may deem necessary for the proper and timely performance of its work, including but not limited to field measurements, soil investigations, laydown areas, interferences and general logistics. No oral representations by any persons regarding such

conditions either before or after the execution of this contract, shall affect or modify any of the terms or obligations herein contained.

8. Structure over Navigable Waters

Where structures are erected in, adjacent to, or over navigable waters, the Contractor shall observe all regulations and instructions of Federal and other authorities having control over such waters. The Contractor shall not obstruct navigation channels without permission from the proper authority and shall provide and maintain navigation lights and signals in accordance with the Federal requirements for the protection of the structure, or falsework, and of navigation.

9. Welding, Burning, and Hot-work Regulations

The U. S. Coast Guard requires JAXPORT to maintain "welding and hot-work" permits valid for 3-year periods that allow JAXPORT and its Contractors to complete any such work on its marine terminal docks. The area of the terminal covered by this program extends landward from the face of the wharf 150 feet. Beyond 150 feet is covered by rules and regulations of the Jacksonville Fire Marshal's Office, and does not require permitting.

- a. The Contractor must contact the designated JAXPORT terminal representative who will inspect the project area in accordance with, and issue the JAXPORT Cutting-Welding-Hot-work Authorization Form.
- b. Once JAXPORT representative has issued the Authorization Form, he will give the Contractor a copy of the U. S. Coast Guard permit, which must be posted by the Contractor in the vicinity of the Contractor's project.
- c. After receiving the completed Authorization Form and posting the U. S. Coast Guard permit in the job area, the Contractor must then contact the U. S. Coast Guard Marine Safety Office, Jacksonville, FL, supplying the following information:
 - (1) U. S. Coast Guard Hot-work permit number
 - (2) The types of hot-work to be accomplished
 - (3) The exact location of the hot-work at the facility.
 - (4) Anticipated duration of the hot-work
 - (5) Type and location of any dangerous cargo on the facility.
 - (6) Name/phone number of the point of contact at the facility.
 - (7) The name of the Contractor.
- d. The Marine Safety Office of Jacksonville will issue a reference number allowing the Contractor to use the JAXPORT Welding and Hot-work Permit" for up to a period of 7 days.
- e. Steps a. through d. must be repeated each 7-day period thereafter until the welding and hot-work portions of the contract is complete.

It is the Contractor's responsibility to comply with all federal, state and local laws.

10. Tax Savings Program, General.

Goods and services purchased directly by the Contractor are subject to all State and/or local taxes. All items, materials, supplies and/or equipment incorporated and/or used in the construction of the project and paid for by the Contractor are, consequently, subject to all applicable taxes.

It is the Contractor's sole responsibility to incorporate any and all applicable taxes into the bid proposal including all railroad materials and equipment for this project without regard to the optional purchasing procedures hereinafter defined. JAXPORT is not a Railroad Company or Railroad Operator, therefore the railroad tax exemption rules do not apply to JAXPORT.

JAXPORT Tax Exemption

Chapter 212 of the Florida Statutes, however, provides JAXPORT with an exemption from the payment of sales taxes for all procurements made directly by JAXPORT.

This section contains the specific administrative and/or purchasing procedures that the Contractor shall follow for the purpose of facilitating JAXPORT's procurement of major items to the extent that JAXPORT may so elect and thereby obtain any benefit that may accrue to JAXPORT from the sales tax exemption permitted by the Florida Statutes.

Administrative and/or Purchasing Procedures.

The following procedures are hereby established to permit JAXPORT to purchase in its own name and for its own account some of the items, equipment, materials and supplies which will form part of the work for which the Contractor is obligated to construct under this contract.

Within a period of time that will not adversely impact the orderly progression of the Project, agreed upon by both JAXPORT and Contractor following notice of contract award, the Contractor shall prepare and submit to the Project Manager an itemization of all items, materials, supplies and/or equipment that will be incorporated into this Project for which the Contractor has a firm quotation and as hereinafter specified. If the Contractor does not have a firm quotation for any items at the time the initial list is prepared, the Contractor shall update the previously submitted list immediately upon obtaining the necessary quotation.

This list shall include all items identified on the plans or in the "Products" section of each Technical Specification that individually or collectively cost \$10,000 or more and would normally be ordered from one supplier under a single Purchase Order. Items that are purchased on an "as needed" basis over time under multiple Purchase Orders, each of which are less than \$10,000, may be excluded from this list even though the aggregate total cost of all items in this category exceeds the \$10,000 minimum.

- a) The list must contain the following:

-
1. A description of item, material, supplies and/or equipment to be procured. This description shall be by common name and be referenced to the technical specification and CSI code under which it is defined.
 2. The quantity of the item, material, supplies and/or equipment to be procured, the unit cost applicable to each, and the appropriate State of Florida and local (Duval County) sales tax rate in which the procurement is delivered.
- b) Within five (5) working days following receipt of the proposed purchasing list or supplemental firm quotation from the Contractor, the Project Manager will notify Contractor of JAXPORT's decision as to which items will be purchased directly by JAXPORT.
- c) Purchase Orders for the selected items will be requested from the Purchasing Department using the Contractor's Letter of Quotation to identify the Vendor name, Contractor, and Not to Exceed amount of Purchase Order. Each Purchase Order will be assigned a number based on the project number and sequence number of Purchase Orders issued.

It shall be understood by the Contractor that these Purchase Order Forms will be issued for the sole and specific purpose of procuring the selected items for incorporation in the Work for which the Contractor is obligated to construct under this contract.

- d) Purchase Orders issued with Letter of Quotation attached, will be forwarded by Project Manager to Contractor with request to complete Purchase Order as to item(s) ordered, delivery instructions, and signature of Contractor.

The Purchase Order, however, shall omit any Florida State or local sales tax. In lieu thereof, JAXPORT's Consumer's Certificate of Exemption No. 85-8012543323C-8 shall be attached to the Purchase Order prior to distribution.

Each Purchase Order shall be completed and countersigned by the Contractor. The Contractor shall be responsible for assuring that the requirements for the procurement, as detailed on the plans and in the Technical Specifications, are satisfied.

- e) Contractor will then return the completed Purchase Order(s) to JAXPORT for countersignature by the Project Manager approving purchase as to conformity to specifications; and to the Purchasing Department for countersignature by the Purchasing Manager.
- f) After obtaining all signatures, the Project Manager shall simultaneously distribute the original to the Vendor or supplier with copies to the Purchasing Department, the Contractor, and the Finance Department.
- g) The Contractor and Owner agree that it is to their mutual benefit that prosecution of the Work proceed with due diligence and without interruption. Vendors of selected items shall therefore make deliveries as directed by the Contractor, when needed, to enable the Contractor to perform his scheduled obligations.

-
- h) JAXPORT and Contractor agree that the Contractor will receive, receipt for, inspect, accept and to the extent necessary, unload, store, and protect the selected items at either the jobsite or other place as the Contractor may deem appropriate until brought to the worksite by the Contractor.

The Contractor shall accept delivery of selected items from the appropriate Vendor as conforming to both the terms and conditions of the Purchase Order and applicable Technical Specifications.

- i) Upon receipt of an invoice for selected items delivered, the Contractor will write on the face of the invoice that it is "okay for payment", sign, and date invoice. The invoice is then submitted in E-Builder to JAXPORT's Project Manager for authorization for payment.
- j) Upon receipt of a properly approved invoice, JAXPORT shall pay the Vendor of the selected items the amount due as defined by the Purchase Order but without any Florida State or local sales tax.

Where the Contractor has special terms with a Vendor to receive a discount if paid within a 10, 30 days' time and if the invoice is received within that time frame, invoices will be processed and the discount taken of which JAXPORT will receive the benefit. The Contractor will be advised by mail when an invoice is forwarded to the Finance Department for payment and the amount to be paid, showing discounts taken by JAXPORT, if any. Otherwise, invoices will be paid within 30 days from date on invoice.

- k) In preparation of its Monthly Progress Payment request, the Contractor shall show on Line 3 of the Application for Payment the total amount of purchase orders issued under this Tax Savings Program. On Line 4 of the Application for Payment, the Contractor will show the amount of tax savings. Line 5 of the Application is the total of Lines 3 and 4.
- l) An adjustment shall be summarized by reporting at the end of the contract and a Change Order to the contract will be made to close out any remaining balances on purchase orders based on the total of payments against each purchase order made for selected items, plus the total sales tax computed. A final reconciliation change order will be issued on all tax savings purchase orders remaining balances based on payments plus sales tax.
- m) Notwithstanding JAXPORT's payment for selected items, as provided for above, the Contractor assumes full responsibility for any change in price and liability associated with selecting and ordering the proper quantity and type of materials and equipment for scheduling the appropriate delivery date, selection of the appropriate Vendor or supplier, the correctness of the Purchase Order and receipt report and the storage, delivery, and protection of the equipment and/or material.
- n) The Contractor shall use Owner approved Purchase Orders only for purchasing goods, equipment, materials and supplies previously designated or selected by JAXPORT. The Contractor shall immediately notify and consult with JAXPORT relative to any change or modification to any previously approved selected

item(s). The Contractor shall account for every Purchase Order including those voided for any reason, and shall return all voided and unused Purchase Order Forms prior to the final contract payment.

- o) If the Contractor enters into one or more subcontracts with respect to any portion of the Work, the Contractor will require that each subcontractor allow, under the terms of their respective subcontracts, JAXPORT to purchase selected item(s) in the same manner as provided above with respect to the Contractor.

The Contractor shall sign all Purchase Orders for selected item(s) required by the subcontractor to complete the portion of the Work required by the subcontract.

11. Progress Photographs

Monthly Applications for Payment (see Article 16 of the "General Conditions") shall be accompanied by not less than 5 color photographs, approximately 3 inches by 5 inches in size showing current status of various areas and components of the Project. Photographs are to be mounted in report form with descriptive captions, and sequentially numbered and uploaded in E-Builder as an attachment to each AFP. The Progress Photograph Report shall contain the following certification on its front cover which requires signature of the Contractor's responsible official.

<p>THIS IS TO CERTIFY THAT THE ATTACHED PHOTOGRAPHS ACCURATELY REPRESENT THE ACTUAL STATUS AND CONDITION ON <u> [DATE] </u> OF THE <u> [CONTRACT TITLE] </u> BEING CONSTRUCTED FOR THE JACKSONVILLE PORT AUTHORITY UNDER CONTRACT NO. <u> [CONTRACT NO.] </u>.</p> <p>FIRM: _____</p> <p>SIGNATURE: _____</p> <p>NAME TYPED: _____</p> <p>TITLE: _____</p> <p>DATE: _____</p>

REQUIRED LIMITS OF INSURANCE

The minimum amounts of insurance (inclusive of any amounts provided by an umbrella policy) shall be as follows:

1. WORKERS' COMPENSATION/EMPLOYERS' LIABILITY

Part One - There shall be no maximum limit (other than as limited by the applicable statute) for liability imposed by the Florida Workers' Compensation Act, or any other coverage required by the contract documents, which are customarily insured under Part One of the standard Workers' Compensation Policy.

Part Two - The minimum amount of coverage required by the contract documents which are customarily insured under Part Two of the standard Workers' Compensation Policy shall be:

- \$100,000 (Each Accident)
- \$500,000 (Disease-Policy Limit)
- \$100,000 (Disease-Each Employee)

2. COMMERCIAL GENERAL LIABILITY

The limits are to be applicable only to work performed under this contract and shall be those that would be provided with the attachment of the Amendment of Limits of Insurance (Designated Project or Premises) endorsement (ISO Form CG 25 01) to a Commercial General Liability Policy with the following minimum limits:

General Aggregate	\$2,000,000
Products/Completed Operations Aggregate	\$1,000,000
Personal and Advertising Injury, Each Occurrence	\$1,000,000
Bodily injury and Property Damage (each occurrence)	\$1,000,000

Owner shall be included as an additional insured under the CGL policy for both ongoing and completed operations. ISO additional insured endorsement CG 20 10 10/1 addition date (for ongoing operations) and CG 20 37 10/1 addition date (for completed operations), or substitute endorsements providing equivalent coverage, will be attached to Contractors CGL.

3. BUSINESS AUTO POLICY

ISO Form Number CA 00 01 covering any auto (code 1), or if contractor has no owned

autos, hired (Code 8) and non-owned autos (Code 9), with limit no less than \$500,000 per accident for bodily injury and property damage.

Failure of Contractor to maintain the required insurance shall constitute a default under this Agreement and, at Owner's option, shall allow Owner to terminate this Agreement.

4. CONTRACTORS POLLUTION LIABILITY

\$ 1,000,000 per loss

\$ 1,000,000 Annual Aggregate

Contractors Pollution Liability coverage will be required for any Environmental/Pollution related services including but not limited to testing, design, consulting, analysis, or other consulting work, whether self-performed or subcontracted, contractor will also maintain Contractor's Pollution Liability coverage. Such coverage will include bodily injury, sickness, disease, mental anguish or shock sustained by any person, including death; property damage including physical injury to or destruction of tangible property including the resulting loss of use thereof, clean-up costs, and the loss of use of tangible property that has not been physically injured or destroyed; defense including costs, charges and expenses incurred in the investigation, adjustment or defense of claims for such compensatory damages; coverage for losses caused by pollution conditions that arise from the operations of the contractor. The Jacksonville Port Authority shall be named as additional insured.

5. UMBRELLA LIABILITY

\$1,000,000 per Occurrence

Minimum underlying coverages shall include Commercial General Liability, Automobile liability and Contractors Pollution Liability.

The umbrella coverage will have drop down insurance coverage.

The contractor's CGL coverage will be primary and non-contributory.

A waiver of subrogation is required for Workers Compensation, GL, and Auto Liability. Contractor waives all rights against Owner and its agents, officers, directors and employees for recovery of damages to the extent these damages are covered by any of the policies of insurance maintained pursuant to this Subcontract. Provide the risk manager with a blanket waiver of subrogation endorsement certificate.

Prior to commencing Work, Contractor shall furnish Owner with certificates of insurance, and copies of additional insured endorsements, executed by a duly authorized representative of each insurer, showing compliance with the insurance requirements set forth below.

Cross-Liability Coverage If Contractor's liability policies do not contain the standard ISO separation of insured's provision, or a substantially similar clause, they shall be endorsed to provide cross-liability coverage.

Subcontractor's' Insurance. Contractor shall cause each subcontractor employed by

Contractor to purchase and maintain insurance of the type specified in this agreement. When requested by Owner, Contractor shall furnish to Owner copies of certificates of insurance evidencing coverage for each subcontractor

No Representation of Coverage Adequacy by requiring the insurance as set out in this Agreement, Owner does not represent that coverage and limits will necessarily be adequate to protect Contractor, and such coverage and limits shall not be deemed as a limitation on Contractor's liability under the indemnities provided to Owner in this Subcontract.

If the Contractor/Consultant maintains broader coverage and/or higher limits than the minimums shown above, the Owner requires and shall be entitled to the broader coverage and/or the higher limits maintained by the contractor/consultant. Any available insurance proceeds in excess of the specified minimum limits of insurance and coverage shall be available to the Owner.

CERTIFICATE OF INSURANCE COMPLIANCE

ADDRESSEE

**Jacksonville Port Authority
 Post Office Box 3005
 Jacksonville, FL 32206-0005
 Attn: Engineering Services
 Contract Specialist**

NAME INSURED

Name and Address of Insured:

By executing this Certificate of Insurance Compliance, the contractor warrants to the addressee that: (1) the undersigned is an authorized representative of the insurers identified in the certificate, (2) the policies or binders described in the certificate have been issued to the above named insured and are in force at this time, (3) the policies or binders as issued provide coverage in full compliance with the insurance requirements contained in the contract documents for the above referenced project with the minimum limits of coverage as specified in the Required Limits of Insurance (Form 100-87) and the contract documents, and (4) the policies or binders will not be changed, cancelled, non-renewed, or renewed with more restrictive terms and conditions so as to affect this certificate until at least thirty (30) days after written notice of such change, cancellation or nonrenewal has been received by the addressee.

Compliance with these insurance requirements shall not relieve or limit the Contractor's liabilities and obligations under this contract. Failure of Addressee to demand such Certificate of Insurance or other evidence of full compliance with these insurance requirements or failure of Addressee to identify a deficiency from evidence provided will not be construed as a waiver of the Contractor's obligation to maintain such insurance.

DESCRIPTION OF INSURANCE POLICIES SUBJECT TO THIS CERTIFICATE

Complete the following section for each of those coverages for which the contractor is making the above warranty. The sum of the limits shown for the primary and excess insurers must equal or exceed the minimum limits required by the contract.

Employer's Liability/Workers' Compensation Limits	Primary Issuer ID: _____	First Excess ID: _____	Second Excess ID: _____
Part One	\$	\$	\$
Part Two (Each Accident)	\$	\$	\$
Disease-Policy Limit			
Disease-Each Employee	\$	\$	\$

Longshoremen's and Harbor Workers'	Primary Issuer ID: _____	First Excess ID: _____	Second Excess ID: _____

Compensation	_____	_____	_____
	\$ _____	\$ _____	\$ _____

Commercial General Liability Limits	Primary Issuer ID: _____	First Excess ID: _____	Second Excess ID: _____
General Aggregate	\$ _____	\$ _____	\$ _____
Products/Completed Operation Aggregate	\$ _____	\$ _____	\$ _____
Personal and Advertising Injury, Each Occurrence	\$ _____	\$ _____	\$ _____
Body injury and property damage	\$ _____	\$ _____	\$ _____
Fire damage (any one fire)	\$ _____	\$ _____	\$ _____
Medical expense (any one person)	\$ _____	\$ _____	\$ _____

Business Auto Liability Limits	Primary Issuer ID: _____	First Excess ID: _____	Second Excess ID: _____
Each Occurrence	\$ _____	\$ _____	\$ _____
Annual Aggregate	\$ _____	\$ _____	\$ _____

Protection for Owner's Liability Limits	Primary Issuer ID: _____	First Excess ID: _____	Second Excess ID: _____
Each Occurrence			
Annual Aggregate			

Or Commercial General Liability Coverage Contains the Described Additional Insured Endorsement YES___ NO___

Property Insurance Risk	Primary Issuer ID: _____	First Excess ID: _____	Second Excess ID: _____

Builder's Risk			
Installation Floaters			
Railroad Protective Liability Coverage			

POLICY AND INSURER INFORMATION

ID	Name of Insurer	Policy Number	Expiration Date	Best's Rating	Authorized in Florida (Y/N)?

Authorized Representative's Name: _____
 (Print and then sign)

Date: _____

Name of Insurance Company: _____

Address of Insurance Company: _____

JACKSONVILLE PORT AUTHORITY

SUMMARY AND CERTIFICATION
"REVISED" APPLICATION FOR PAYMENT NO.

PROJECT NAME:
PROJECT LOCATION: DATE:
JPA CONTRACT NO: C-1752 A/E PROJECT NO.:
CONTRACTOR:
APPLICATION PERIOD: TO:

1. ORIGINAL CONTRACT SUM.....	\$ _____
2. MODIFICATION BY CHANGE ORDERS (THRU C.O. #5).....	\$ _____
3. LESS: Purchase Orders issued by JPA for material selected for tax savings.....	\$ _____
4. LESS: State and Local Tax savings on material purchase orders.....	\$ _____
5. LESS: TOTAL PURCHASE ORDERS & TAX SAVINGS.....	\$ _____
(Line 3 plus Line 4)	
6. CURRENT CONTRACT VALUE.....	\$ _____
7. TOTAL COMPLETED & STORED TO DATE.....	\$ _____
8. RETAINAGE WITHHELD:	
_____ % of Completed Work	
_____ % of line 7).....	\$ _____
10. TOTAL EARNED LESS RETAINAGE WITHHELD.....	\$ _____
11. LESS PREVIOUS PAYMENTS RECEIVED.....	\$ _____
12. AMOUNT DUE THIS PAYMENT.....	\$ _____

SUMMARY OF APPROVED CHANGE ORDERS			SUMMARY TAX SAVING'S PURCHASE ORDERS			CONTRACTOR'S CERTIFICATION
No.	Date Appd.	Value (+ -)	No.	Date Appd.	Value (+ -)	
						The undersigned CONTRACTOR certifies that: (1) all items and amounts shown above are correct; (2) all Work performed and materials supplied fully comply with the terms and conditions of the Contract Documents; (3) all previous progress payments received from JAXPORT on account of Work done under the Contract referred to above have been applied to discharge in full all obligations of CONTRACTOR incurred in connection with Work covered by prior Applications for Payment; (4) title to all materials and equipment incorporated in said Work or otherwise listed in or covered by this Application for Payment will pass to JAXPORT at time of payment free and clear of all liens, claims, security interests and encumbrances; and (5) if applicable, the CONTRACTOR has complied with all provisions of Article V of the Specification documents including the payment of a pro-rata share to JSEB, MBE, WBE, DBE and/or SBA Firms of all payments previously received by the CONTRACTOR.
TOTALS: \$ _____			TOTALS: \$ _____			

BY THE OWNER'S CONSULTANT

I hereby certify that, to the best of my knowledge, and belief, based in part on actual site observations, the Contractor has satisfactorily completed the work represented in this Application for Payment in accordance with requirements of the contract documents, and payment of the current amount due to the Contractor is recommended.

Firm: _____

By: _____

Title: Date: _____

JPA APPROVAL FOR PAYMENT

By: _____

Date: _____

Project Acct.: _____

FORM AFP-1

State of Florida, County of Duval

Subscribed and sworn to **before me this**

_____ day of _____ 20_____ -

By: _____ -

Title: _____ Date: _____

who is/are personally known to me or has/have produced _____ (type of identification)

as identification.

Notary Signature: _____ -

Commission No.: _____ -

(Name of Notary typed,

Printed or Stamped)

My Commission Expires: _____ -(SEAL ABOVE)

REVISED 09/12/2013



C-1752 Request for Information

Date Created: _____

Answer Company	Answer By	Author Company	Authored By

Co-Respondent	Author RFI Number

Subject	Discipline	Category

Question	Date Required

Submitted By: _____ Date: _____

Suggestion

Answer	Date Answered:

Submitted By: _____ Date: _____

AGREEMENT BETWEEN OWNER AND CONTRACTOR

This Agreement is entered into as of this ____ day of _____, 20__ by and between:

The OWNER:

**Jacksonville Port Authority
2831 Talleyrand Avenue
Post Office Box 3005
Jacksonville, FL 32206-0005
(904) 357-3065**

ATTN: Procurement Services

And the CONTRACTOR:

**Awarded Contractor Name
Awarded Contractor Address
Awarded Contractor Phone
Number
Insert Vendor Number**

For the following WORK:

**Contract No.: C-1752
Project No.: T2021.07
DESIGN-BUILD TERMINAL
FACILITIES BUILDINGS
Talleyrand Marine Terminal**

Designed by CONSULTANT:

In-House

The OWNER and CONTRACTOR agree as set forth below:

ARTICLE 1. SCOPE OF WORK

The Contractor agrees to furnish all materials, equipment, supervision and perform all labor and services for Contract No. **C-1752** as shown on the contract drawings and described in the project specifications, each document of which is incorporated herein by reference and listed under Article 2 hereof.

ARTICLE 2. CONTRACT DOCUMENTS

The contract documents, which constitute the entire Agreement between the Owner and the Contractor, are enumerated below and all are as fully a part of the contract as if attached to this Agreement Form or repeated herein.

1. Agreement between Owner and Contractor.
2. Exhibits and Attachments to this Agreement.
3. Contractor's Bid, Performance Bond, and Statutory Payment Bond.
4. Contractor's Bid Form.
5. Invitation to Bidders.
6. Supplementals Instruction to Bidders.
7. Conflict of Interest Certificate.
8. General Conditions of the contract.
9. Supplementary Conditions of the contract.
10. Special Conditions of the contract.
11. Technical Specifications.
12. Drawings entitled: _____
13. Addenda Nos. _____ through _____, inclusive.
14. Change Orders, duly authorized and delivered after execution of this Agreement.
15. Notice of Award.
16. Notice to Proceed.
17. Certificate of Contract Completion and Contractors Affidavit to Owner.
18. Certificate of Substantial Completion.
19. Approved Contractor's Construction Schedule for the Work.
20. Contractor's Schedule of Values for the Work.
21. Contractor's Request for Information Form.
22. Owner's Minimum Project Work Rules.
23. Required Limits of Insurance.
24. Certificate of Insurance Compliance.
25. Application for Payment Forms.
26. Form of Consent of Surety Company to Final Payment.
27. SEB Participation Goal – Sheltered (**100%**) JSEB/DBE/SBA/WBE/MBE

ARTICLE 3. CONTRACT TIME

1. Contract Time. Time is of the essence for all Work in this contract. The Contractor shall totally and finally complete the Work within **180** calendar days from Notice to Proceed date.
2. Liquidated Damages. Refer to "Special Conditions", Item 2.

ARTICLE 4. CONTRACT SUM

For the performance of the Work and in accordance with the terms of the contract documents, the Owner will pay to the Contractor, subject to additions and deductions by Change Order, the Contract Sum of:

\$ _____

ARTICLE 5. PROGRESS PAYMENTS

See "General Conditions", Section IV.3.a.

ARTICLE 6. FINAL PAYMENT

The Owner shall cause to be paid, to the Contractor, a final payment constituting the entire unpaid balance of the Contract Sum, when the Work has been completed, the Contract and closeout procedures are fully performed, and the Project Manager has reviewed and approved the final application.

ARTICLE 7. MISCELLANEOUS PROVISIONS

1. Terms. Terms used in this Agreement which are defined in the Conditions of the contract shall have the meaning designated therein.
2. Contract Bonds. The Contractor shall furnish a Performance Bond, and Statutory Payment Bond for 100 percent of the Contract Sum as security for the faithful performance and payment of all obligations under the contract documents.
3. Indemnity. In addition to the indemnity provisions of General Conditions Section V.1.g., the Contractor shall hold harmless, indemnify and defend the JPA, its board of directors, officers, employees, representatives and agents against any claim, action, loss, damage, injury, liability, cost and expense of whatsoever kind or nature, including but not limited to attorney's fees and court costs arising out of any injury, whether mental or corporeal, to persons, including death, or damage to property to the extent caused by the negligence, recklessness or intentional wrongful misconduct of the Contractor, its employees, representatives, or any one acting on the Contractor's behalf in the performance of this contract, or any claim or damage or claim damage related to alleged breach of contract.
4. Access to Documents. The Owner shall be provided daily reports in possession of the Contractor. Owner shall also have access to any other documents related to the project, upon reasonable notice.
5. Subcontracting or Assigning of Contract. The Contractor agrees that it shall not

subcontract, assign, delegate, or otherwise dispose of the contract, the duties to be performed under the contract, or the monies to become due under the contract without the Owner's prior written consent.

IN WITNESS WHEREOF, the parties hereto have duly executed this Agreement as of the day and year first above written.

OWNER

CONTRACTOR

JACKSONVILLE PORT AUTHORITY

BY: _____

BY: _____

TITLE: _____

TITLE: _____

ATTEST:

ATTEST:

**CERTIFICATE OF CONTRACT COMPLETION
AND CONTRACTOR'S AFFIDAVIT TO OWNER**

CONTRACT: **C-1752**

STATE OF ()

COUNTY OF ()

Before me, the undersigned authority,

Personally appeared _____, who being by me

First duly sworn, depose(s) and say(s):

1. He is (they are) _____, (a corporation)
(a partnership) (an individual) doing business as
_____, hereinafter called "Contractor".

2. Contractor heretofore entered into a contract with the Jacksonville Port Authority, hereinafter called "Owner", to furnish material, labor, and services for the construction of a certain building; or repairs or alterations as more specifically described in said contract, on the land and property of the Owner, located at _____, Duval County, Florida.

3. Contractor has fully completed construction in accordance with the terms of the contract and all creditors have been paid in full, except:

<u>Name of Creditor</u>	<u>Amount Due and Unpaid</u>
_____	\$ _____
_____	\$ _____

4. All Workers' Compensation claims have been settled and no liability claims are pending in connection with, arising out of or resulting from, the contract.

5. Receipt by the Contractor of the final payment, under the aforementioned contract, shall constitute a full release and discharge by the Contractor to the Owner of any and all claims of the Contractor against the Owner arising out of, connected with, or resulting from performance of the obligations of the Contractor pursuant to the contract documents.

6. The term "Creditor" as used in this Affidavit means subcontractors, laborers, material men, architects, engineers, landscape architects, surveyors, and all other persons, firms, corporations and activities supplying, performing, or otherwise providing anything of value used for or in connection with the contract.

7. This Affidavit is given pursuant to the provisions of the contract and applicable law, if any. Signed and Sealed in the presence of:

Sworn to and subscribed before me this _____ day _____, 20__.

Notary Public, State of _____
My Commission Expires: _____

**CONSENT OF
SURETY COMPANY
TO FINAL PAYMENT**

OWNER
ENGINEER
CONTRACTOR
FIELD
OTHER

PROJECT:XXXPrjName
(name, address)

PROJECT NO.XXXPrjFinNo

TO (Owner)

CONTRACT NO.:XXXPrjName

JACKSONVILLE PORT AUTHORITY
POST OFFICE BOX 3005
JACKSONVILLE, FL 32206-0005

ARCHITECT'S PROJECT NO.

CONTRACT FOR:

ATTN: ENGINEERING SERVICES

CONTRACT DATE:

CONTRACTOR:

In accordance with the provisions of the Contract between the Owner and the Contractor as indicated above, the
(here insert name and address of Surety Company)

SURETY COMPANY,

On bond of (here insert name and address of Contractor)

CONTRACTOR,

hereby approves of the final payment to the Contractor, and agrees that final payment to the Contractor shall not
relieve the Surety Company of any of its obligations to (here insert name and address of Owner)

OWNER,

as set for in the said Surety Company's bond.

IN WITNESS WHEREOF,

The Surety Company has hereunto set its hand this _____ day of _____ 20____

Surety Company

Signature of Authorized Representative

Attest:
(Seal):

Title

OWNER'S MINIMUM PROJECT WORK RULES

Project Name: **Design-Build Terminal Facilities Buildings**

Location: **Talleyrand Marine Terminal**

Contract No(s): **C-1752**

1. Normal project working hours are as follows:

8:00 A.M.	Starting Time
12:00 Noon - 1:00 P.M.	Lunch
5:00 P.M.	Shift Ends

Other working hours and shift work will be considered by the Owner upon submission by the Contractor.

2. No employee will enter Port Authority operating areas without a specific work assignment.
3. Personal vehicles will be parked in the area(s) specified for construction personnel.
4. No personal vehicles will be permitted inside the security gate controlled area without the written permission of the Terminal Director.
5. Contractor shall provide its employees with a designated eating, drinking area subject to approval of the Project Manager. Cleanliness will be maintained in all areas at all times. The parking lot is not an authorized eating area.
6. The following is a list of violations which are considered unsatisfactory conduct on JAXPORT property and can result in the employee being denied access to the jobsite.
 - a. Refusal to submit to security inspection.
 - b. Smoking in prohibited areas.
 - c. Possession and/or use of intoxicants on JAXPORT property.
 - d. Possession and/or use of narcotics or controlled substance on JAXPORT property.
 - e. Possession of firearms on JAXPORT property.
 - f. Contact with any new vehicles on JAXPORT property.
7. Owner's facilities (such as, but not limited to, elevators, washrooms, vending machines, lunch rooms, etc.) are not to be used by Contractor's employees.
8. Employees shall be provided with visible means of identification, showing Contractor's identification. Employees are required to wear this identification where plainly visible.
9. The Contractor will be responsible for all its employees, suppliers, vendors, and all others on-site providing services to the Contractor.

-
10. All vehicles, persons, packages, lunch pails, and tool boxes entering or leaving JAXPORT property are subject to security inspection.
 11. All vehicles on-site for the Contractor's use must have company identification clearly visible at a minimum distance of 100 feet.

EMPLOYEE SIGNATURE: _____

EMPLOYEE NAME: _____

NAME OF CONTRACTOR: _____

DATE: _____

OWNER'S SAFETY GUIDELINES

Project Name: **Design-Build Terminal Facilities Buildings**

Location: **Talleyrand Marine Terminal**

Contract No(s): **C-1752**

The safety items listed below is not intended as an exhaustive list of safety requirements but serves as a general guideline.

Safety Manual

The contractor is responsible to provide JAXPORT with an electronic copy of their jobsite specific safety manual that provides safety guidance on day to day work activities to reduce potential safety incidents at the jobsite.

Regulatory Requirements

The contractor and subcontractors will be responsible to:

- Comply with OSHA 29 CFR parts 1917 marine terminals, 1926 construction, 1910 general, 1926.59 hazardous communication standards "right-to-know".
- Post Material safety data sheets (MSDS) in work locations where contractor uses, or stores hazardous chemicals or substances as required by law.
- Contractor and subcontractor will comply with all environmental protection laws and regulations applicable to the jobsite, including those relating to the use of water, the release, discharge or disposal of wastes, the control of drainage, and the protection of vegetation, wildlife, habitats, or surroundings. Contractor and subcontractor shall also observe and comply with any environmental requirements made by JAXPORT in securing any permit or authorization for the jobsite.
- Communicate and wear OSHA required personal protective equipment when on the job site (i.e. reflective vests with Company's identification, gloves, hard hats, safety glasses, steel toe shoes, etc.).
- If applicable ensure that platforms and scaffolding conform to OSHA specifications and have decking, toe boards, mid and top rail, cross bracing, level pads and/or wheels and appropriate ladders for platform access. Ensure the use of continuous fall protection equipment (scaffolds and/or harnesses) when activities take place more than 6'-0" above a lower level or at such lower elevations as may be established for the work site.
- If it becomes necessary to have access to any openings or shafts or to remove handrails, contractor and or subcontractor shall ensure that the openings or shafts are protected in accordance with generally accepted practices and any applicable federal, state or local safety standards while the work is in progress, and that any covers or handrails previously removed by the contractor and or subcontractor are replaced before leaving the area.

OWNER'S SAFETY GUIDELINES

Jobsite Requirement

- Contractor will provide safety barriers to clearly identify the working area to prevent others from accessing the work area. The safety zone shall be sufficiently sized to prevent damage to others or existing facilities and structures. Upon completion of the work, Contractor shall remove the safety barriers from the work area.
- Maintain clean work areas and secure and protect all work materials in accordance with safety requirements of generally recognized industry standards.
- Additional safety rules and/or measures may become necessary at any time due to near misses, change in jobsite location, etc.
- Familiarize and abide by JAXPORT safety rules for the jobsite.
- Communicate frequency of safety meeting with its employees and list the topics discussed with signatures of attendees. Such list shall be made available to JAXPORT upon request.
- Perform self-audits (safety assessments) at least monthly and document and provide findings to JAXPORT project management and Risk and Compliance manager upon request.

Incident/Emergency Response Plan

- As soon as possible, but no longer than 2 hrs. after the time of incident, advise JAXPORT of any incident resulting in injury or damage to any property. A written report of the incident will be submitted to the supervising JAXPORT Project Manager and JAXPORT's Manager of Risk and Compliance (904) 357-3083 within 24 hours. Daily updates will be provided to JAXPORT until an investigation is completed.
- Provide JAXPORT on-site management with an "emergency list" showing contractor's preferred company doctor, hospital, workers' compensation insurance company, and any other health care providers, such list to be updated within 24 hours of any change in the information provided. Contractor shall furnish its employees with first aid or refer employees with first aid injuries to its company doctor.

Audit and Training

- Contractor is responsibility to train, manage, supervise, monitor, and inspect contractors and subcontracted jobsite work activities enforcing compliance with all applicable federal, state, local laws and JAXPORT safety rules and requirements.
- Documentation of required training must be readily available and in compliance with OSHA requirements.
- JAXPORT personnel may audit contractors and subcontractor's safety processes/programs at the jobsite at any time and empowered to take necessary corrective action up to and including work stoppage for serious safety hazards.

OWNER'S SAFETY GUIDELINES

EMPLOYEE SIGNATURE: _____

EMPLOYEE NAME: _____

NAME OF CONTRACTOR: _____

DATE: _____

PERFORMANCE BOND

BOND NO.: _____

As to the Contractor/Principal:

Name: _____

Principal Business Address: _____

Telephone: _____

As to the Surety:

Name: _____

Principal Business Address: _____

Telephone: _____

As to the Owner of the Property/Contracting Public Entity:

Name: _____

Principal Business Address: _____

Telephone: _____

Description of project including address and description of improvements:

Contractor and Surety are each held and firmly bound unto the Jacksonville Port Authority, a body politic and corporate in Duval County, Florida, as Obligee (hereinafter called "JPA"), in the amount of _____ DOLLARS (\$ _____), lawful money of the United States of America, for the payment whereof Contractor and Surety bind themselves, their respective heirs, executors, administrators, legal representatives, successors and assigns, jointly and severally, firmly by these presents.

WHEREAS, Contractor has by written agreement dated the _____ day of _____, 20____, entered into a contract with the JPA for **Design-Build Terminal Facilities Buildings, Talleyrand Marine Terminal** all of said work to be done in strict accordance with any advertisement for bids for said work and done in strict compliance with the drawings and specifications for said work and requirements of the JPA proposal and award therefore and of the contract and all documents included as a part of the contract (hereinafter referred to collectively as the "Contract"), all of which are by reference made a part hereof to the same extent as if fully set out herein.

NOW, THEREFORE, THE CONDITION OF THIS OBLIGATION is such that, if Contractor shall: (1) Promptly and faithfully perform said Contract; and (2) perform the guarantee of all work and materials furnished under the Contract for the time specified in the Contract; and (3) pay the JPA all losses (including delay and disruption damages), expenses and costs, that the JPA sustains because of a default by Contractor under the Contract; then this obligation shall be null and void; otherwise it shall remain in full force and effect.

PROVIDED that, the Surety hereby waives notice of any alteration or extension of time made by the JPA, and any changes in or under the Contract and compliance or noncompliance with any formalities connected with the Contract or the changes shall not affect Surety's obligation under this bond.

PROVIDED further that, whenever Contractor shall be, and declared by the JPA to be in default under the Contract, the JPA having performed the JPA's obligations hereunder, the Surety shall, at the JPA's sole option, either:

(1) Within fourteen (14) days of notice of elected option by the JPA, remedy the default and pay the JPA all losses, actual damages (including delay and disruption damages), expenses, costs, and statutory attorney's fees, including appellate proceedings, pursuant to Section 627.756, Florida Statutes, that the JPA sustains because of a default by Contractor under the Contract and will save the JPA harmless on account of all claims and damages to persons, property or premises arising from delay in meeting either milestone dates or the Contract completion date; or

(2) Award a bid contract with a completion contractor and issue notice to proceed within twenty-one (21) days of notice by the JPA to the Surety of the default of Contractor and demand by the JPA for Surety to complete the Contract. Surety shall obtain a bid or bids for completing the Contract in accordance with its terms and conditions, and upon determination by Surety of the lowest responsible qualified bidder, or, if the JPA elects, upon determination by the JPA and the Surety jointly of the lowest bidder and the JPA, and make available as Work progresses (even though there should be a default or a succession of defaults under the contract or contracts of completion arranged under this paragraph) sufficient funds to pay the cost of completion less the responsible qualified bidder, arrange for a contract between such balance of the contract price, including other

losses, actual damages (including delay and disruption damages), expenses, costs and statutory attorney's fees, including appellate proceedings, pursuant to Section 627.756, Florida Statutes, for which the Surety may be liable hereunder. The term "balance of the contract price" as used in this paragraph, shall mean the total amount payable by the JPA to Contractor under the Contract and any amendments thereto, less the amount properly paid by the JPA to Contractor; or

(3) Within fourteen (14) days of notice of elected option by the JPA, tender to the JPA the full amount necessary in order for the JPA to completely perform and carry out completion of the Contract in accordance with its terms and conditions and in order to save the JPA harmless on account of all claims and damages to persons or property, and pay the JPA for all losses, actual damages (including delay and disruption damages), including those arising from delay in meeting either milestone dates or the Contract completion date, expenses, costs and statutory attorney's fees, including appellate proceedings, pursuant to Section 627.756, Florida Statutes.

PROVIDED further that, the Surety shall save the JPA harmless from any and all damages, including expenses, costs, contractual damages, injury, negligence or default, patent infringement and actual damages (including delay and disruption damages) and assessments which may arise by virtue of any defects in work or materials within a period of one (1) year from the date on which the JPA makes final payment under the Contract.

PROVIDED further that, during any interim period after the JPA has declared Contractor to be in default but Surety has not yet remedied the default in the manner chosen by the JPA, Surety shall be responsible for securing and protecting the work site including, but not limited to, the physical premises, structures, fixtures, materials, and equipment, and shall be responsible for securing and protecting materials and equipment stored off-site.

PROVIDED further that, no right of action shall accrue on this bond to or for the use of any person or corporation other than the JPA named herein or the heirs, executors, administrators or successors of the JPA.

IN WITNESS WHEREOF, the said Principal and the said Surety have duly executed this bond the ____ day of _____, 20____.

ATTEST:

ATTEST:

By: _____ By: _____
Its Its
AS PRINCIPAL

**SIGNED, SEALED AND DELIVERED
IN THE PRESENCE OF:**

ATTEST:

ATTEST:

By: _____ By: _____
Its Its
AS SURETY

NAME OF AGENT: _____

ADDRESS: _____

TELEPHONE NO: (____)_____ **FACSIMILE NO:** (____)_____

Countersigned:

By: _____ **Bond I.D. No:** _____
State of Florida

Name of Firm: _____

Address: _____

NOTE: DATE OF BOND MUST NOT BE PRIOR TO DATE OF CONTRACT.

CONTRACT NUMBER _____
PAYMENT BOND
CONTRACT BOND REQUIRED
BY SECTION 255.05, FLORIDA STATUTES

Bond No. _____

As to the Contractor/Principal:

Name: _____

Principal Business Address: _____

Telephone: _____

As to the Surety:

Name: _____

Principal Business Address: _____

Telephone: _____

As to the Owner of the Property/Contracting Public Entity:

Name: _____

Principal Business Address: _____

Telephone: _____

Description of project including address and description of improvements:

Contractor and Surety are each held and firmly bound unto the Jacksonville Port Authority, as a group, and each member individually, as Obligee (hereinafter called Owner), in the amount of _____ DOLLARS (\$ _____), lawful money of the United States of America, for the payment whereof Contractor and surety bind themselves, their respective heirs, executors, administrators, legal representatives, successors and assigns, jointly and severally, firmly by these presents.

WHEREAS, Contractor and Owner have by written agreement dated the ____ day of _____, 20____, entered into a contract for **C-1752 Design-Build Terminal Facilities Buildings, Talleyrand Marine Terminal** all of said work required to be done in strict compliance with the drawings, plans and specifications prepared by the Jacksonville Port Authority Engineering and Construction Department for said work and in strict compliance with the requirements of the contract and all documents included as a part of the contract (hereinafter referred to collectively as the Contract), all of which are by reference made a part hereof to the same extent as if fully set out herein.

Promptly makes payments to all lienors or claimants supplying labor, materials and supplies used directly or indirectly by Contractor in the prosecution of the work provided for in the Contract, including any authorized extensions or modifications thereof, then this bond is void; otherwise, it remains in full force and effect.

PROVIDED, that the Surety hereby waives notice of any alteration or extension of time made by the Owner, and any changes in or under the Contract and compliance or noncompliance with any formalities connected with the Contract or with the changes do not affect Surety's obligation under this bond.

PROVIDED, further, that no action shall be instituted or prosecuted against the Contractor or the Surety on the bond after one (1) year from the performance of the labor or completion of delivery of the materials or supplies, or the date the rental equipment was last on the jobsite available for use.

IN WITNESS WHEREOF, the said Principal and the said Surety have duly executed this bond the ____ day of _____, 20____.

ATTEST:

ATTEST:

By: _____

By: _____

Its

Its PRINCIPAL

SIGNED, SEALED AND DELIVERED IN THE PRESENCE OF:

ATTEST:

ATTEST:

By: _____

By: _____

Its

Its SURETY

NAME OF AGENT: _____

ADDRESS: _____

TELEPHONE NO. (____)_____

FACSIMILE NO: (____)_____

Countersigned:

By: _____

Bond I.D. No: _____

State of Florida

Name of Firm: _____

Address: _____

NOTE: DATE OF BOND MUST NOT BE PRIOR TO DATE OF CONTRACT.



SCOPE OF WORK

FOR

**DESIGN-BUILD TERMINAL FACILITIES
BUILDINGS**

Project No.: T2021.07

Contract No.: C-1752

TALLEYRAND MARINE TERMINAL

PROJECT NO. T2021-07
JAXPORT CONTRACT NO. C-1752
TERMINAL FACILITIES BUILDINGS
SCOPE OF WORK

1.0 DESCRIPTION

The work includes, but is not limited to, providing all labor, materials, equipment, incidentals, subcontracts, and supervision necessary or manifestly required to design, permit, furnish, and construct pre-engineered metal buildings (PEMB) as specified in the attached Section 13 34 19 Metal Building Systems at JAXPORT's Talleyrand Marine Terminal, as shown in the project drawings. The work includes, but is not limited to: footings/foundations, steel framing/structure, metal roofing, metal siding (walls), power, lighting, grounding, roof vent system, lightning protection system (if required by Code), reinforced concrete floor, gutters, and downspouts.

2.0 CONTRACTOR RESPONSIBILITIES

Contractor's responsibilities include, but are not necessarily limited to:

- 2.1** Design of PEMB and all elements required to file and secure all necessary permits. The design shall: site preparation, building foundations, electrical (power and lighting), and any and all other elements necessarily required to render a complete and useable facility. The design and construction shall meet all applicable building codes utilizing documents signed and sealed by a Florida registered Professional Engineer. See attached specification SECTION 13 34 19 METAL BUILDING SYSTEMS for specifications directly related to PEMB design and construction.
- 2.2** Contractor shall secure all necessary permits.
- 2.3** Contractor shall provide or cause to be provided all surveying, layout, and stake out that may be required to complete the project in accordance with the drawings and specifications.
- 2.4** Contractor shall construct PEMBs in accordance with approved designs and permits.
- 2.5** Contractor shall perform earthwork (excavation, backfill, grade, compaction, etc.) as required to prepare the foundations and the base for the buildings.
- 2.6** Contractor shall "Proof roll" and compact soil as needed. All disturbed areas incidental to construction, including but not limited to asphalt areas, shall be returned to pre-construction conditions.

- 2.7** Contractor shall perform the following testing: (1) soil compaction to confirm at least 95% theoretical compaction of the site before starting construction work, (2) concrete compressive strength testing on cylinders taken from each 10 CY of concrete placed, (3) testing of electrical systems and lighting protection if required by Codes. All testing required by all applicable codes, standards and regulations, including but not limited to: FDOT, JPA, COJ, NEC, ASTM, ACI, NFPA (collectively the "Codes").
- 2.8** Contractor shall inspect the site prior to design and construction. Contractor shall locate and field verify all utility locations prior to execution of work. Contractor shall confirm, in the field, all utility appurtenances with the Owner prior to the commencement of construction.
- 2.9** Contractor shall protect existing utilities, survey markers, monuments during construction.
- 2.10** Contractor shall restore/replace any damage resulting from construction activities. Contractor shall be responsible for any damage caused to existing JAXPORT property or JAXPORT tenant property caused by Contractor's operations.
- 2.11** Contractor shall promptly remove all construction debris and trash from JAXPORT Property.
- 2.12** Contractor shall comply with all federal, state, local, and JAXPORT Safety requirements.
- 2.13** Contractor shall provide notification of any radioactive testing devices (such as X-ray weld inspections, ground penetrating radar, nuclear density testing, etc.) that it intends to utilize on or transport to the Talleyrand terminal not later than 48 hours prior to such usage/transport.
- 2.14** All Coordination and Scheduling shall be through the JAXPORT Project Manager.
- 2.15** JAXPORT shall have fourteen (14) calendar days after receipt of the design to provide review comments.

3.0 BASE BID AND OWNER'S OPTION

- 3.1 Base Bid.** The Base Bid is all the design and construction work necessary to construct a 50 ft. x 100 ft PEMB as indicated on Drawing No. _____. This PEMB shall have an electrically operated rollup door.
- 3.2 Owner's Option 1.** Owner's Option 1 is all the design and construction work necessary to construct a second PEMB as indicated as on Drawing No. _____. JAXPORT has the right to exercise Owner's Option 1 not later than 100 calendar days after JAXPORT issues the NTP for the design of the Base Bid PEMB. Contractor shall not be allowed additional mobilization and demobilization costs for Owner's Option 1.

4.0 WORK HOURS

Work may be conducted from 7:00 am to 7:00 pm, 7 days per week, unless otherwise directed by the JAXPORT Project Manager. Night work is not allowed. Contractor shall comply with all local noise ordinances

5.0 CONTRACT TIME

5.1 Base Bid – Storage Building

5.1.1 Design Phase. JAXPORT will issue a Notice to Proceed (NTP) for the design of the Base Bid work, after which Contractor shall have 114 calendar days to complete the design and secure all necessary permits.

5.1.2 Construction Phase. JAXPORT will issue the NTP for construction after design is complete and Contractor has obtained permits. Contractor shall have 150 calendar days after issuance of the construction NTP to complete all Base Bid work.

5.2 Owner’s Option 1 – Equipment Building

5.2.1 .Design Phase. The written exercise of Owner’s Option 1 by JAXPORT shall constitute the NTP for Contractor to commence design and permitting. Contractor shall have 114 calendar days to complete the design and secure all necessary permits

5.2.2 Construction Phase. JAXPORT will issue the NTP for construction after design is complete and Contractor has obtained permits. Contractor shall have 150 calendar days after issuance of the construction NTP to complete all Owner’s Option 1 work.

6.0 MAINTENANCE OF TRAFFIC (MOT)

In case any traffic pattern may be affected by the Contractor’s execution of this job, then prior to mobilization Contractor shall prepare and deliver to the Owner for approval a MOT plan that clearly depicts all items necessary for work sequencing. It is paramount that terminal operations be safely maintained throughout the entirety of the work. Contractor is responsible, at all times, for clearly identifying and isolating the area of construction and safely routing all vehicular, heavy equipment, and pedestrian traffic around the construction area. Contractor shall incorporate signage/cones and/or barricades in an effort to direct and maintain any and all on-going operations traffic.

7.0 SPECIFICATIONS

7.1 Metal Building Systems. The attached Technical Specification SECTION 13 34 19 METAL BUILDING SYSTEMS is incorporated into and made a part of the contract documents.

- 7.2 Gutters and Downspouts.** 24-gage, zinc-coated (galvanized) steel sheet or aluminum-zinc alloy-coated steel sheet pre-painted.
- 7.3 Electrical.** All materials and equipment shall comply with all applicable codes, standards, and regulations, including but not limited to: NEC, NFPA, and NEMA, and shall be commercial grade and rated for outdoor use. Contractor shall include conduits, conductors, lighting fixtures, switches, outlets, breaker panels, and all other material/equipment manifestly required to provide suitable power and lighting to the buildings. Submit for review and approval all material and equipment prior to installation.
- a. 2" aluminum rigid conduits (exposed interior/exterior).
 - b. 4" electrical PVC conduits (if buried conduits are needed).
 - c. Low Bay LED Light Fixtures. A submittal including a layout plan shall be submitted by the Contractor and accepted by JAXPORT prior to any work.
 - d. OFF / ON 2-way switches for the lights – industrial rated.
 - e. 120 V electrical outlets (duplex) equally spaced – industrial rated.
 - f. 240 V electrical outlet – industrial rated.
 - g. New meter – per NEC and Jacksonville Electrical Authority (JEA) requirements.
- 7.4 Lightning Protection System.** All materials and installation shall comply with NEC, NFPA, Contractor's design, and manufacturer's recommendations. Contractor shall submit all material information prior to procuring materials.
- 7.5 Concrete.**
- 7.5.1** Concrete shall have a minimum 28-day compressive strength of 4,000PSI. All concrete materials and work shall comply with approved mix designs, and all applicable codes, standards and regulations, including but not limited to ACI 318, ACI 301, and ASTM.
- 7.5.2** Concrete reinforcement for floor slabs shall be ASTM A185, GR. 65 W.W.F. (welded wire fabric), per the Contractor's design. Industrial Fiber Reinforcement may not be used as an alternate to W. W. F.
- 7.6 Backfill material for subsurface preparation.** All material needed for backfill, including material to substitute for any removed soil, shall comply with the latest FDOT and ASTM standards.
- 7.7 Asphalt.** All asphalt materials and work shall comply with FDOT Standard Specifications for Road and Bridge Construction (July 2021), Sections 911 and 916.



DRAWINGS

FOR

**DESIGN-BUILD TERMINAL FACILITIES
BUILDINGS**

Project No.: T2021.07

Contract No.: C-1752

TALLEYRAND MARINE TERMINAL

TALLEYRAND MARINE TERMINAL TERMINAL FACILITIES BUILDINGS

LEGEND	
SHEET NUMBER	SHEET DESCRIPTION
1	VICINITY MAP & LOCATION MAP
2	SITE MAP
3	BASE BID - STORAGE BUILDING CONCEPT
4	OWNER'S OPTION 1 - EQUIPMENT BUILDING CONCEPT
5	EXISTING UTILITIES



VICINITY MAP & PROJECT LOCATION
NTS

H:\Mar_eng\Projects in Development\03_TMT_CB - TMT Terminal Facilities Buildings\02_CAD_Files & Graphics\CAD_Files\TMT Terminal Facilities Building_07-27-2021.dwg, Jul 27, 2021, 2:31:06PM, Inru

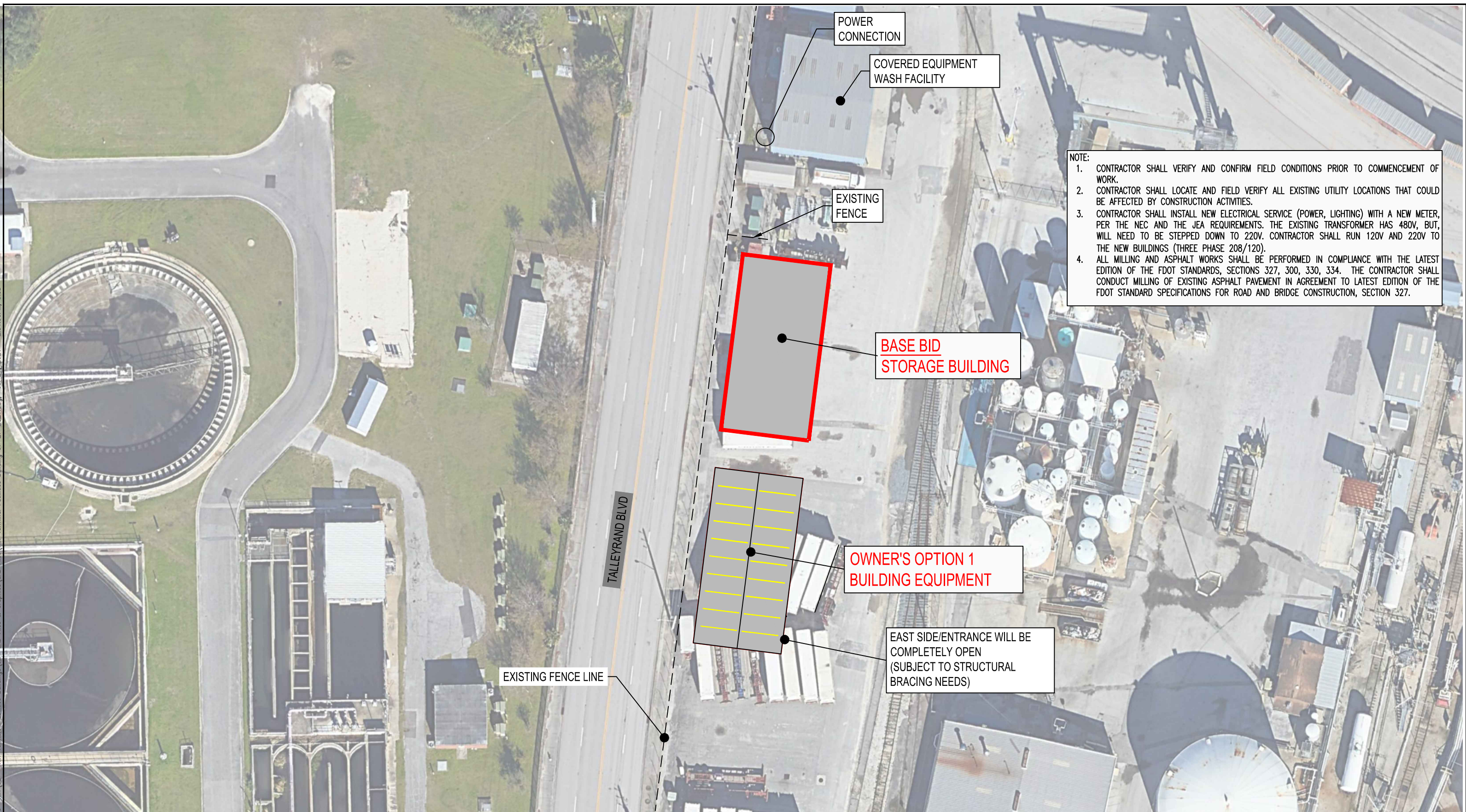

NOTE:

1. CONTRACTOR SHALL VERIFY AND CONFIRM FIELD CONDITIONS PRIOR TO COMMENCEMENT OF WORK.
2. CONTRACTOR SHALL LOCATE AND FIELD VERIFY ALL EXISTING UTILITY LOCATIONS THAT COULD BE AFFECTED BY CONSTRUCTION ACTIVITIES.
3. CONTRACTOR SHALL INSTALL NEW ELECTRICAL SERVICE (POWER, LIGHTING) WITH A NEW METER, PER THE NEC AND THE JEA REQUIREMENTS. THE EXISTING TRANSFORMER HAS 480V, BUT, WILL NEED TO BE STEPPED DOWN TO 220V. CONTRACTOR SHALL RUN 120V AND 220V TO THE NEW BUILDINGS (THREE PHASE 208/120).
4. ALL MILLING AND ASPHALT WORKS SHALL BE PERFORMED IN COMPLIANCE WITH THE LATEST EDITION OF THE FDOT STANDARDS, SECTIONS 327, 300, 330, 334. THE CONTRACTOR SHALL CONDUCT MILLING OF EXISTING ASPHALT PAVEMENT IN AGREEMENT TO LATEST EDITION OF THE FDOT STANDARD SPECIFICATIONS FOR ROAD AND BRIDGE CONSTRUCTION, SECTION 327.

PROJECT SITE
1"=50'

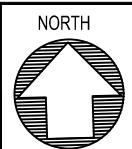

TALLEYRAND MARINE TERMINAL
TERMINAL FACILITIES BUILDINGS
SITE MAP

SHEET	2 OF 5
DATE	7/27/2021
PROJECT NO.	T2021-07
CONTRACT NO.	C-1752

H:\Mar_eng\Projects in Development\03 TMT\CB - TMT Terminal Facilities Buildings\02 CAD Files & Graphics\CAD Files\TMT Terminal Facilities Building 07-27-2021.dwg, Jul 27, 2021 - 2:54:45PM, theu

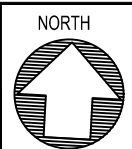
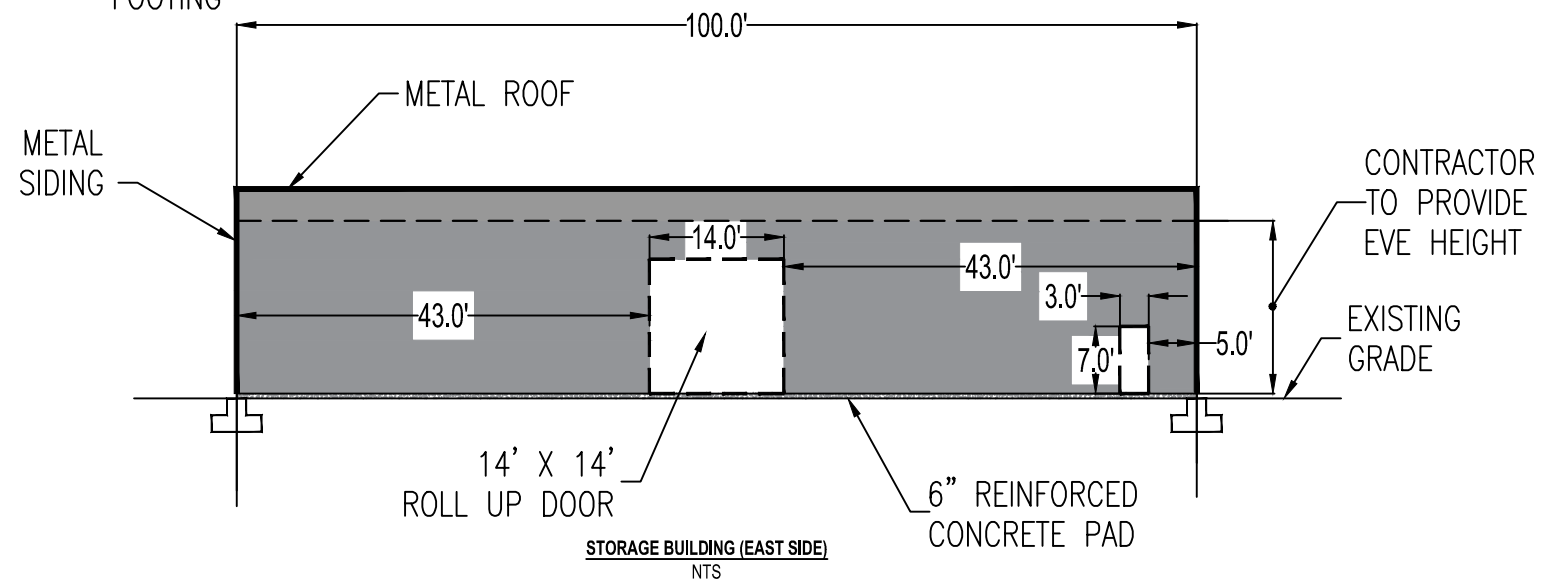
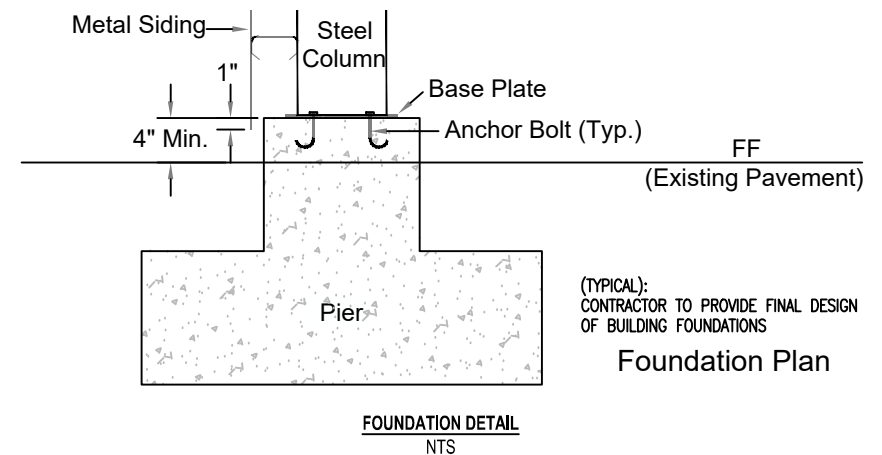
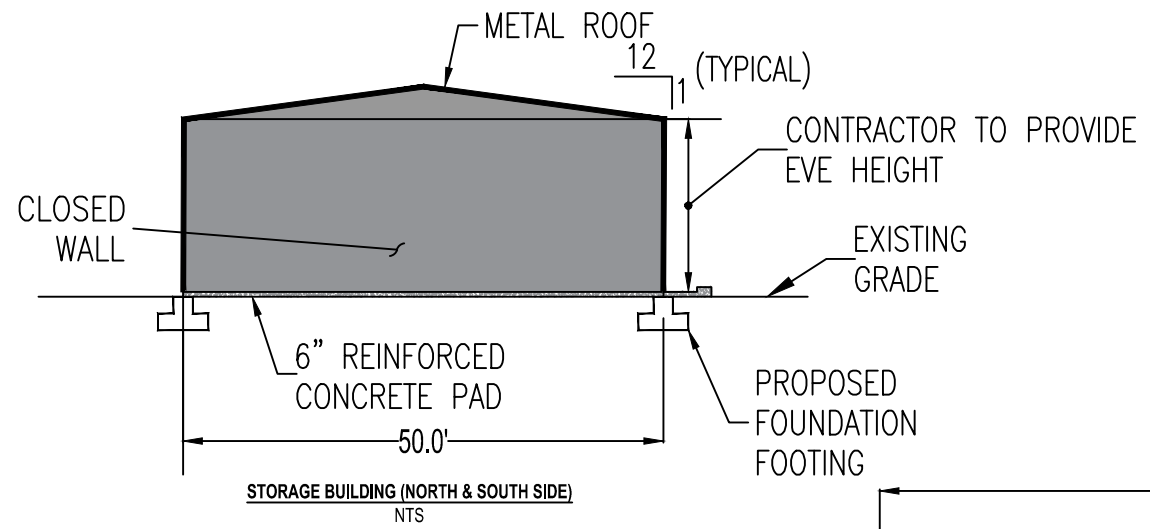
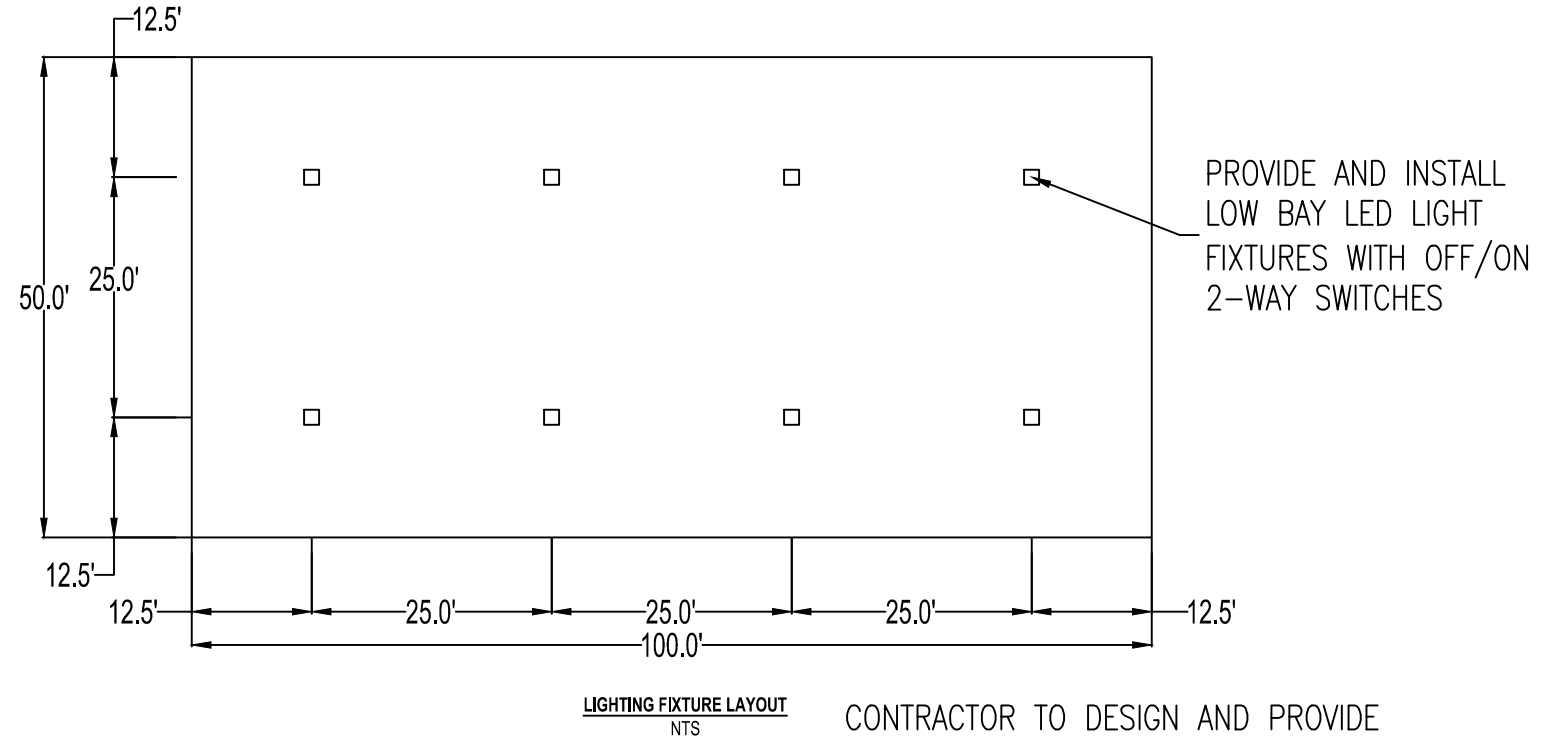
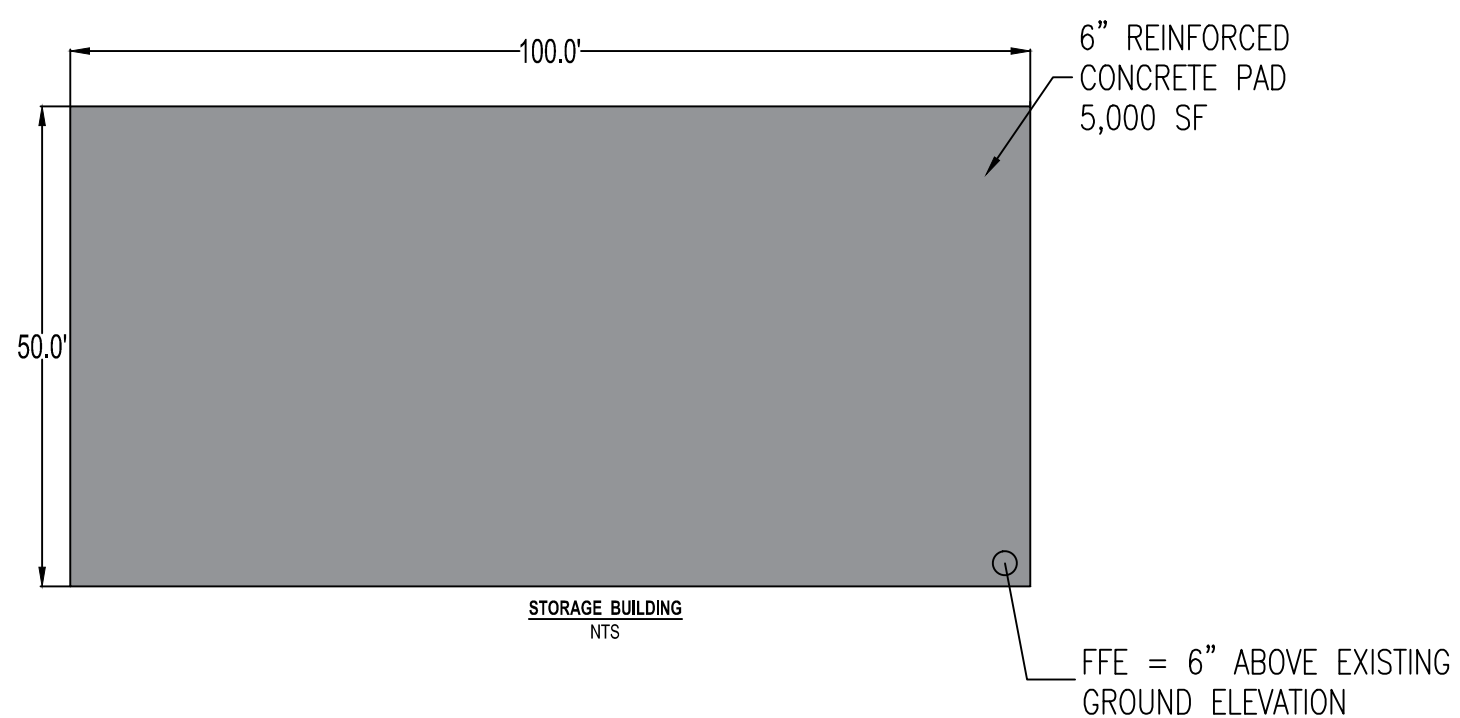

TALLEYRAND MARINE TERMINAL
TERMINAL FACILITIES BUILDINGS
BASE BID - STORAGE BUILDING
CONCEPT

SHEET	3 OF 5
DATE	7/27/2021
SCALE	NTS
PROJECT NO.	T2021-07
CONTRACT NO.	C-1752

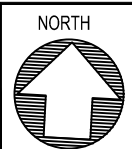
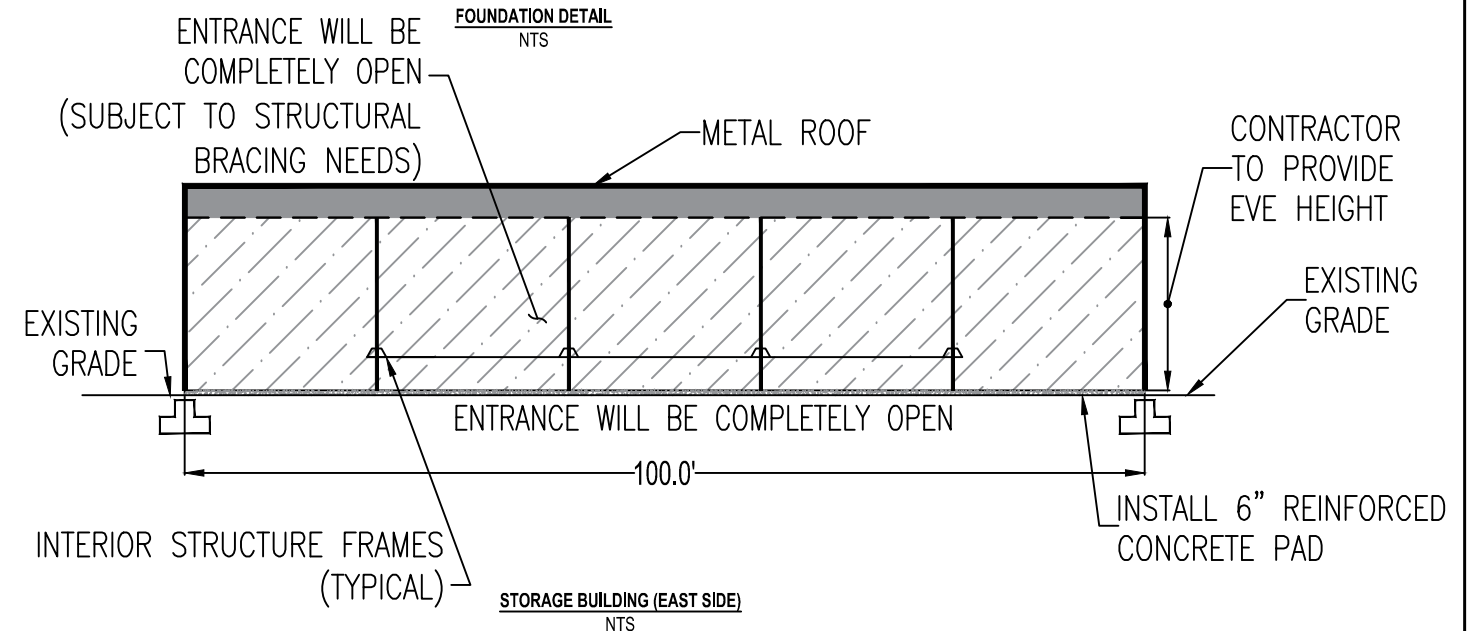
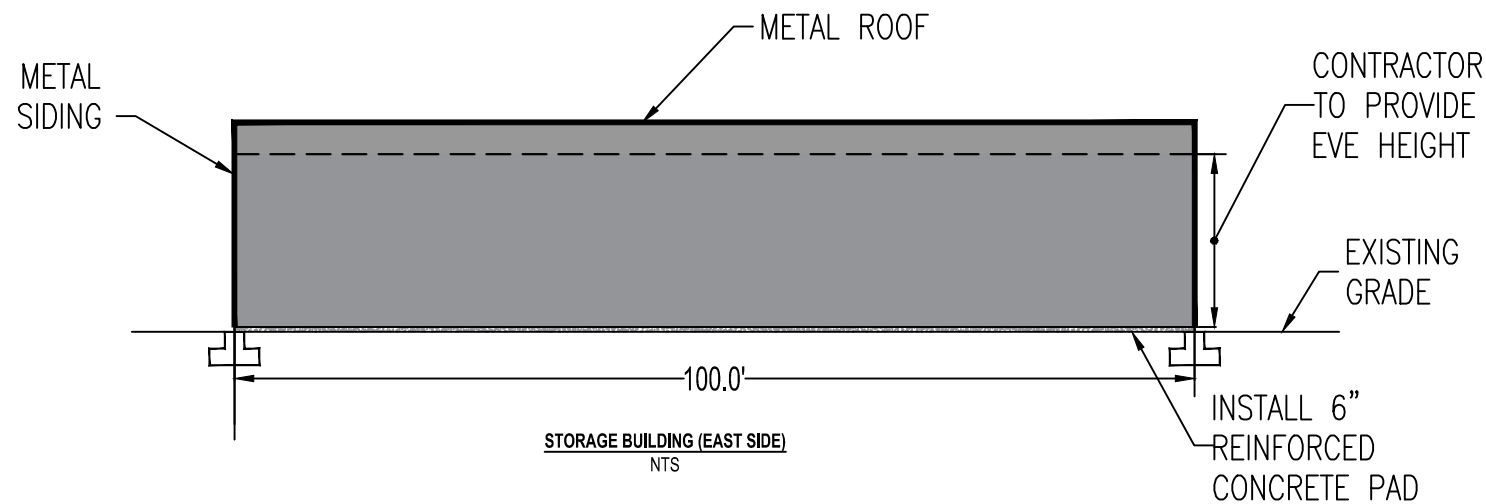
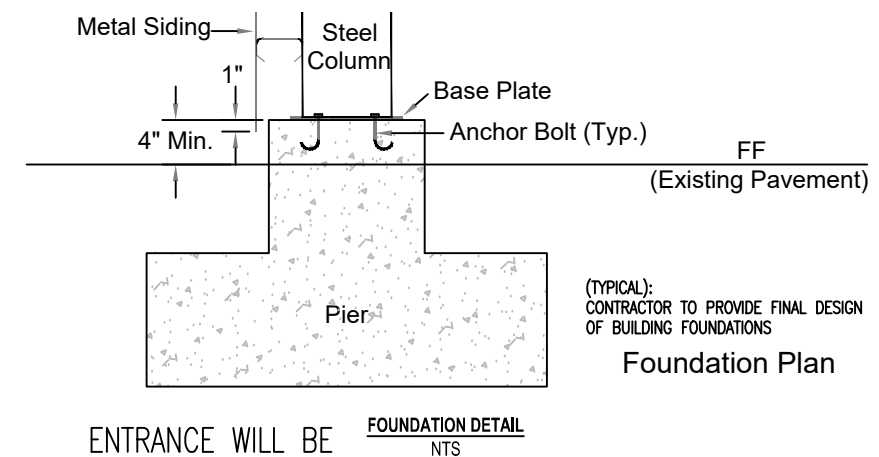
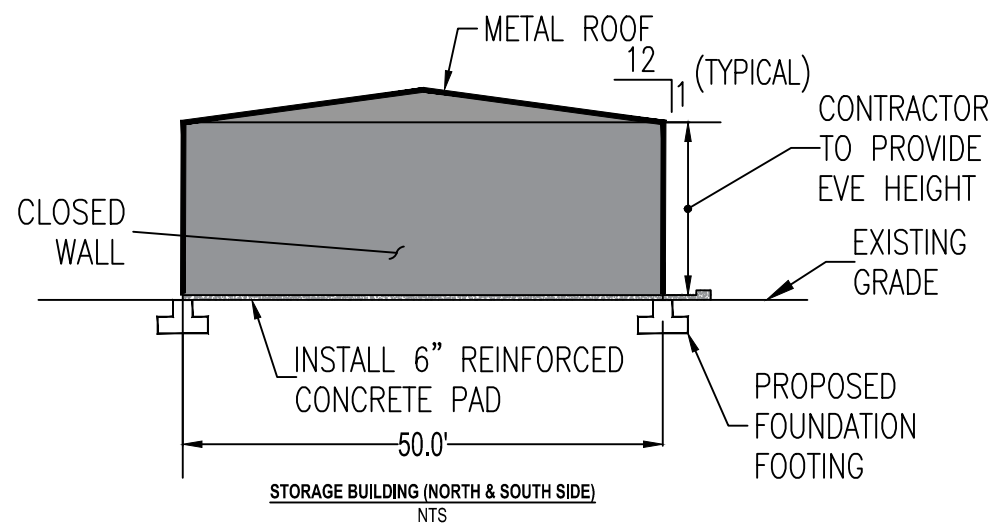
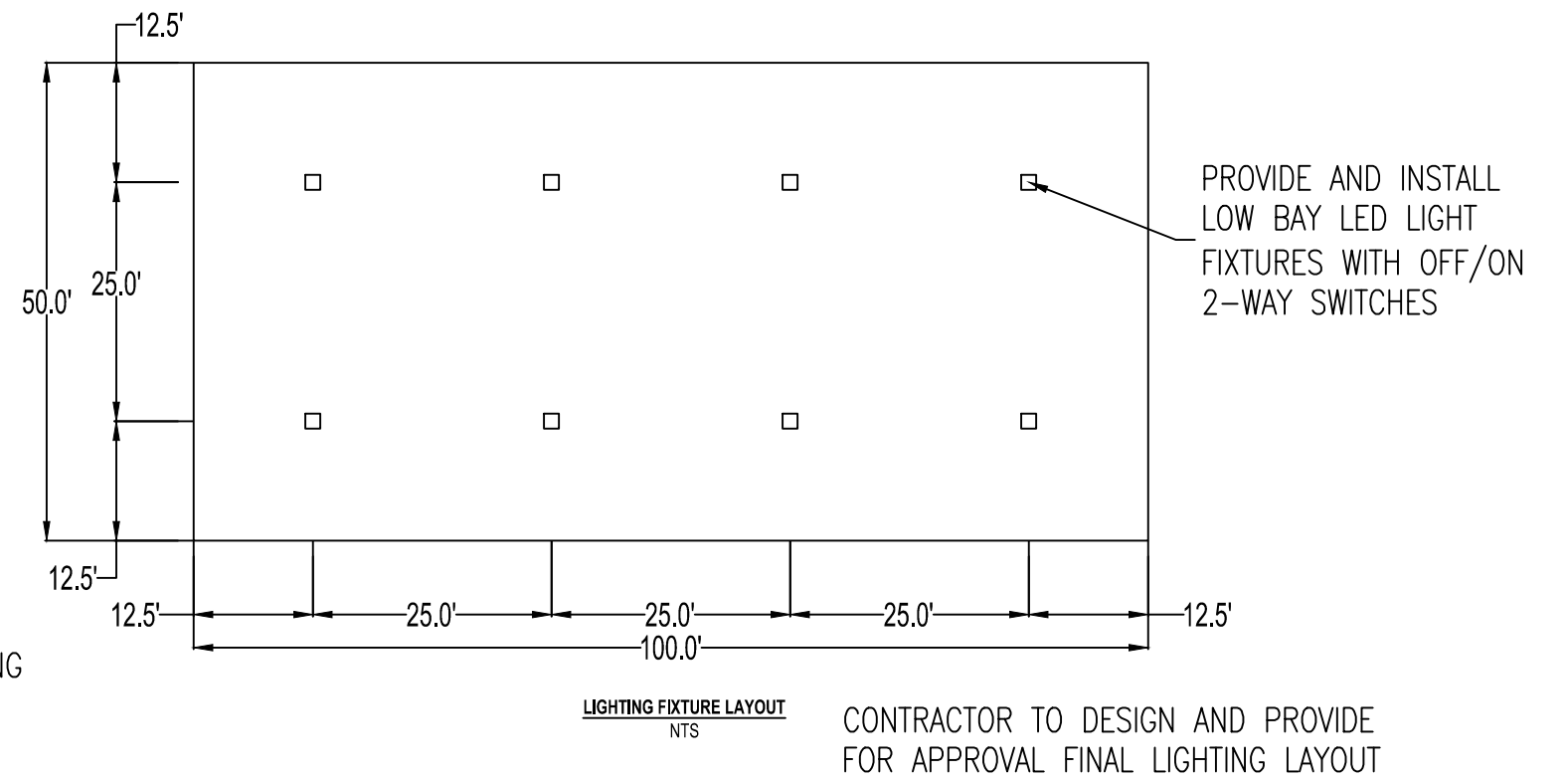
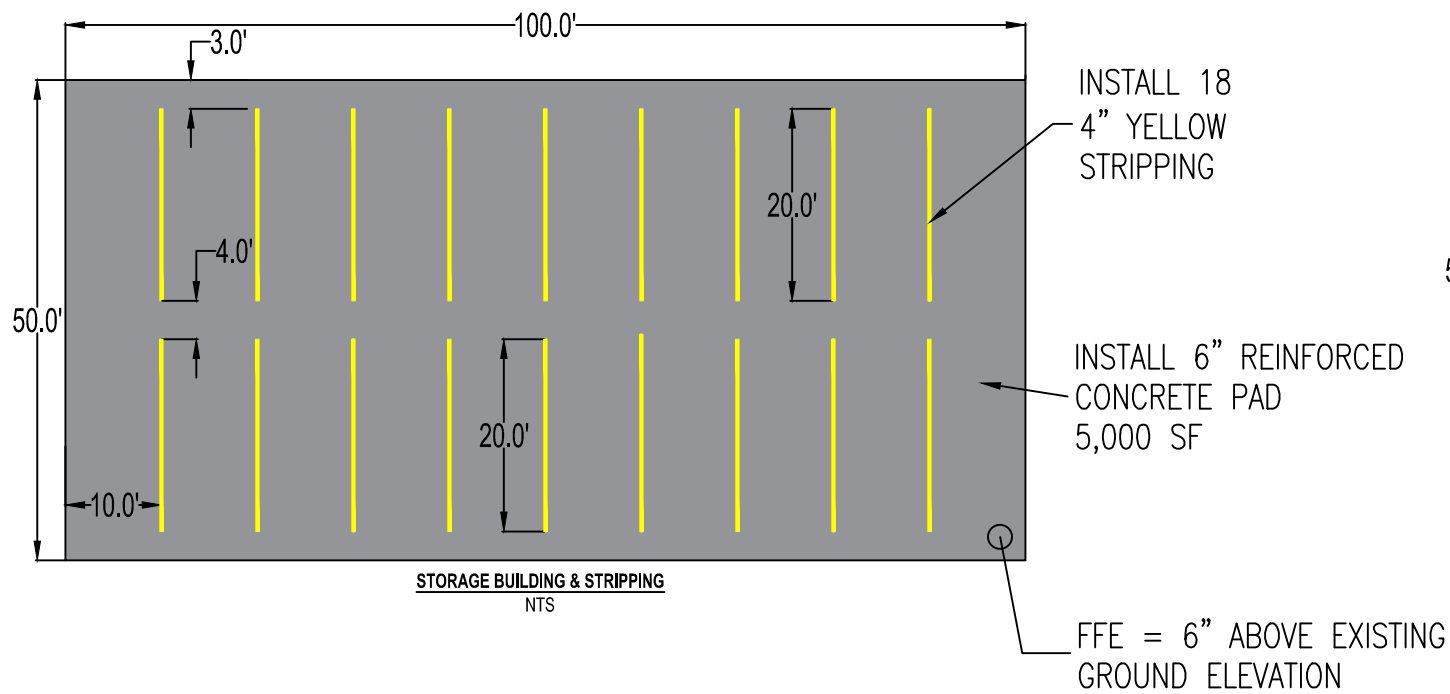

TALLEYRAND MARINE TERMINAL
TERMINAL FACILITIES BUILDINGS
OWNER'S OPTION 1 - EQUIPMENT BUILDING
CONCEPT

SHEET	4 OF 5
DATE	7/27/2021
SCALE	NTS
PROJECT NO.	T2021-07
CONTRACT NO.	C-1752



BASE BID STORAGE BUILDING
OWNER'S OPTION 1 BUILDING EQUIPMENT



TMT UTILITIES	
■	STORMWATER_INLET
▲	STORMWATER_ENDWALL
●	STORMWATER_MANHOLE
—	STORMWATER_PIPE
▲	SEWER_PUMP_STATION
○	SEWER_MANHOLE
—	SEWER_FORCEMAIN
—	SEWER_MAIN
+	POTABLE_WATER_VALVE
▲	POTABLE_WATER_HYDRANT
■	POTABLE_WATER_BACKFLOW
—	POTABLE_WATER_MAIN
+	ELECTRIC_TRANSFORMER
■	ELEC. or LIGHT POLE
▲	ELECTRIC_METER
●	ELECTRIC_MANHOLE
—	ELECTRIC_CABLE
—	UTILITY_CORRIDOR
Map Base	
■	JAXr3c4

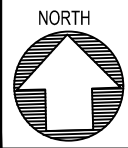

TALLEYRAND MARINE TERMINAL
EQUIPMENT BUILDING & PARKING
EXISTING UTILITIES

SHEET	5 OF 5
DATE	7/27/21
SCALE	NTS
PROJECT NO.	T2021-07
CONTRACT NO.	C-1752

SECTION 13 34 19
METAL BUILDING SYSTEMS

PART 1 GENERAL

1.1 REFERENCES

1.1.1 Publications

ALUMINUM ASSOCIATION (AA)

- | | |
|--------|---|
| AA ADM | (2020) Aluminum Design Manual |
| AA ASD | (2017; Errata 2017) Aluminum Standards and Data |

AMERICAN INSTITUTE OF STEEL CONSTRUCTION (AISC)

- Steel Construction Manual, 15th Edition
- | | |
|-------------|--|
| AISC 341-16 | (2021) Seismic Provisions for Structural Steel Buildings |
| AISC 360-16 | (2021 errata) Specification for Structural Steel Buildings |

AMERICAN IRON AND STEEL INSTITUTE (AISI)

- | | |
|-----------|---|
| AISI D100 | (2017) Cold-Formed Steel Design Manual |
| AISI D110 | (2016) Cold-Formed Steel Framing Design Guide, 2016 Edition |

AMERICAN SOCIETY OF CIVIL ENGINEERS (ASCE)

- | | |
|---------------|--|
| ASCE/SEI 7-16 | (2017; Errata 2018; Supp 1 2018) Minimum Design Loads and Associated Criteria for Buildings and Other Structures |
|---------------|--|

AMERICAN ARCHITECTURAL MANUFACTURER'S ASSOCIATION (AAMA)

- | | |
|------------|---|
| AAMA 605.2 | Voluntary Specification for High Performance Organic Coatings on Architectural Extrusions and Panels |
| AAMA 606.1 | Voluntary Guide Specifications and Inspection Methods for Integral Color Anodic Finishes for Architectural Aluminum |

AMERICAN SOCIETY FOR TESTING AND MATERIALS (ASTM)

ASTM A36	(2019) Standard Specification for Structural Steel
ASTM A123	(2017) Standard Specification for Zinc (Hot-Dip Galvanized) Coatings on Iron and Steel Products
ASTM A153	(2016a) Standard Specification for Zinc Coating (Hot-Dip) on Iron and Steel Hardware
ASTM A242	(2018) Standard Specification for High-Strength Low-Alloy Structural Steel
ASTM A307	(2021) Standard Specification for Carbon Steel Bolts, Studs, and Threaded Rod 60 000 PSI Tensile Strength
ASTM A463	(2020)e1 Standard Specification for Steel Sheet, Aluminum-Coated, by the Hot-Dip Process
ASTM A529	(2019) Standard Specification for High-Strength Carbon-Manganese Steel of Structural Quality
ASTM A563	(2015) Standard Specification for Carbon and Alloy Steel Nuts
ASTM A653	(2020) Standard Specification for Steel Sheet, Zinc-Coated (Galvanized) or Zinc-Iron Alloy-Coated (Galvannealed) by the Hot-Dip Process
ASTM A755	(2018) Standard Specification for Steel Sheet, Metallic Coated by the Hot-Dip Process and Prepainted by the Coil-Coating Process for Exterior Exposed Building Products
ASTM A780	(2020) Standard Practice for Repair of Damaged and Uncoated Areas of Hot-Dip Galvanized Coatings
ASTM A792	(2021) Standard Specification for Steel Sheet, 55% Aluminum-Zinc Alloy-Coated by the Hot-Dip Process
ASTM A992	(2020) Standard Specification for Structural Steel Shapes
ASTM A1008	(2020) Standard Specification for Steel, Sheet, Cold-Rolled, Carbon, Structural, High-Strength Low-Alloy, High-Strength Low-Alloy with Improved Formability, Required Hardness, Solution Hardened, and Bake Hardenable
ASTM A1011	(2018a) Standard Specification for Steel, Sheet and Strip, Hot-Rolled, Carbon, Structural, High-Strength Low-Alloy, High-Strength Low-Alloy with Improved Formability, and Ultra-High Strength
ASTM B209	(2014) Standard Specification for Aluminum and Aluminum-Alloy Sheet and Plate

ASTM E84 (2021a) Standard Test Method for Surface Burning Characteristics of Building Materials

BUILDING CODES

FBC-B (2020) Florida Building Code 7th Edition – Building
FBC-P (2020) Florida Building Code 7th Edition - Plumbing
FBC-M (2020) Florida Building Code 7th Edition - Mechanical
NFPA 70 (2017) National Electric Code

METAL BUILDING MANUFACTURER'S ASSOCIATION (MBMA)

MBMA MBSM (2018) Metal Building Systems Manual
MBMA MBS-SDG (2019) Seismic Design Guide For Metal Building Systems

1.1.2 Reference Drawings

- a. .
- b. .
- c. .

1.2 GENERAL REQUIREMENTS

1.2.1 Summary

Design and construct pre-engineered metal buildings of the size, shape, height, siting and configuration, including gutters and downspouts, as indicated in the reference drawings identified in paragraph 1.1.2 including gutters and downspouts, all in accordance with the building manufacturer's specifications and recommendations, the applicable reference publications, this specification, and the reference drawings.

1.2.2 Design Requirements

- A. System: Complete pre-engineered metal building (PEMB) package using manufacturer's standard components.
- B. Structure: Rigid modular: solid-member, structural framing system with interior columns.
- C. Primary Framing: Rigid frame of rafter beams or joists, columns, and wind bracing.
- D. Secondary Framing: Purlins, girts, eave struts, flange bracing, clips, and other items detailed.
- E. Roof System: Preformed metal panels of up slope profile with sub-girt framing/anchorage assembly, and accessory components.
- F. Roof Slope: Roof slope must be manufacturer's standard for frame type required.

- G. Exterior Wall System: Provide factory assembled, un-insulated metal wall panels.
- H. Wall & Roof Panels Finish All panels are to receive a factory-applied polyvinylidene fluoride of Kynar 500/Hylar 5000 finish consisting of a baked-on top-coat with a manufacturer's recommended prime coat. Color of wall panel shall be chosen by JAXPORT from the manufacturer's color charts.
- I. Paint System: Other than wall panels, all other components shall receive manufacturer's standard preparation, primer, and paint all compatible with the conditions existing at the construction sites. All paint (except for field touch-up) shall be factory-applied.
- J. Bay Spacing: As shown on reference drawings.
- K. Structural Loading Requirements

<u>Description</u>	<u>Load</u>
Metal Building	Building's own dead load
Design Wind Load	Per ASCE 7 map and methods (Wind Speed: 130 mph; Exposure Category "B"; I=1.0)

- L. Building Code Requirements: Design building, roof system, roof overhang (if any) including support framing, roof and wall panels, and fasteners for horizontal and uplift wind loads to meet requirements of ANSI/ASCE 7-95, Minimum Design Loads for Buildings and Other Structures; other requirements to conform to the Florida Building Code 7th Edition (2020) – Building (in particular, Section 2214 - Section 2224).
- M. Design members to withstand dead load and design loads due to pressure and suction of wind calculated in accordance with applicable Codes
- N. Maximum allowable deflection: Per Florida Building Code 7th Edition (2020) – Building, with imposed loads for exterior wall and roof system.
- O. Size and fabricate wall and roof systems free of distortion or defects detrimental to appearance or performance.
- P. Provide drainage to exterior for water entering or condensation occurring within wall or roof system.
- Q. Permit movement of components without buckling, failure of joint seals, undue stress on fasteners or other detrimental effects, when subject to temperature range as recommended by manufacturer for the proposed location.
- R. Building Foundation: Include reinforced concrete foundation designs compatible with the sites, the reference drawings, and manufacturer's recommendations, if any.
- S. Lightning Protection/Grounding: If required by Code, include design and testing.
- T. Electrical and Lighting: Include electrical service and lighting designs per applicable Codes.

1.3 MATERIAL SUBMITTALS

- A. Manufacturer's Literature and Technical Data: Drawings and specifications for proposed metal building system.
- B. Product Data: Submit data on profiles, component dimensions, fasteners, and performance characteristics.
- C. Samples: Submit one samples of precoated metal panels for each color selected, 12 X 12 in. in size illustrating color and texture of finish.
- D. Manufacturer's Instructions: Submit preparation requirements and anchor bolt placement.
- E. Paint Systems: Specifications including paint manufacturer's name, product trade-name, and preparation procedure for shop and field applied paint systems.
- F. Shop Drawings
 - 1) All drawings must be signed and sealed by a professional engineer registered in the State of Florida and prepared specifically for this Project.
 - 2) Calculations signed and sealed by a professional engineer registered in the State of Florida.
 - 3) Indicate assembly dimensions, locations of structural members, connections, attachments, cambers, loads; wall and roof system dimensions, panel layout, general construction details, anchorages and method of anchorage, framing anchor bolt settings, sizes, and foundation loads; indicate welded connections with AWS A2.4 welding symbols.

1.4 QUALITY CONTROL SUBMITTALS

- A. Erector Statements of Qualification

Building erection firm shall be approved by the building manufacturer and must specialize in performing work as described in this Section with a minimum of five (5) years documented experience. Documentation shall include project name, location, type and date completed, building manufacturer, and owner's contact person. Submit this information not later than 30 calendar days after issuance of NTP.
- B. Manufacturer's written instructions for shipping, handling, storage, protection and erection or installation of building and components.
- C. Manufacturer's certification or proof of current membership in Metal Building Manufacturer's Association (MBMA).
- D. Contract Closeout Submittals
 - 1) Manufacturer's Certificate of proper installation.
 - 2) Operations and Maintenance Manual.
 - 3) As-built record drawings in CAD & pdf format.

1.5 SHIPPING, HANDLING AND STORAGE

A. Delivery

Package and deliver components, sheets, metal panels, and other manufactured items so as not to be damaged or deformed and protected during transportation and handling. Individual parts are to be tagged.

B. Storage

Stack and store metal panels horizontally on platforms or pallets, covered with suitable weather-tight and ventilated covering to ensure dryness, with positive slope for drainage of water. Store in a manner to prevent bending, warping, twisting, and surface damage. Do not store metal wall panels in contact with other materials that might cause staining, denting, or other surface damage. Retain strippable protective covering on metal panel for entire period up to metal panel installation.

1.6 WARRANTY

Furnish manufacturer's written 5-year warranty for pre-engineered building systems and components, with JAXPORT named as beneficiary. The warranty shall provide for correction or at JAXPPORT's option, removal and replacement of roof and wall panels, flashing, trim and accessories if found to be defective during a period of 5 years after the date of Substantial Completion. The 5-year warranty shall include coverage for exterior pre-finished surfaces color coat against chipping, cracking, checking, crazing, blistering, peeling, flaking, chalking, fading or lose adhesion. Include coverage for weather tightness of building enclosure elements after installation.

PART 2 PRODUCTS

2.1 PRE-ENGINEERING BUILDING MANUFACTURERS

Products manufactured or supplied by the following firms and meeting these Specifications may be used on this Project:

- A. American Buildings Company
- B. Butler Manufacturing Company
- C. Metallic Building Company
- D. Star Building Systems
- E. Varco-Pruden

2.2 COMPONENTS

A. Framing and Bracing

- 1) Structural Steel: ASTM A36 or A529 with factory primer compatible with finish coating.
- 2) Secondary Framing: Cold-Rolled Galvanized ASTM A607, Class 1, Grade 55.
- 3) Minimum thickness of structural steel for main beams and columns shall be 3/16 inch.

- 4) Bracing in the plane of the roof and vertical wall bracing shall be round rods; cables will not be allowed.

B. Roof and Wall Panels

- 1) Roof Panels: ASTM A446 ribbed steel panels; minimum 24-gauge galvanized steel with roll-formed corrugations for structural stiffness and appearance. Basis of Design: SSR stamping seam roof with panel rib at 24 inches OC. Finish: Per paragraphs 1.2.2.h and 1.2.2.i in a color selected by JAXPORT from manufacturer's standard colors.
- 2) Wall Panels: Minimum 26-gauge galvanized steel with finish Per paragraphs 1.2.2.h and 1.2.2.i in a color selected by JAXPORT from manufacturer's standard colors. Match panel cross section with existing panels on adjacent buildings.

2.3 ACCESSORIES

- A. Trim: Factory-formed and factory-painted ridge cap, rake trim, simple eave trim, panel side trim, corner trim, door trim, and other trim as necessary.
- B. Miscellaneous: Furnish panel fasteners, weather sealing compounds, roof jacks, bolts, nuts, gaskets, and other necessary components.

2.4 FABRICATION

A. Factory Fabrication

To manufacturer's written standards, MBMA Metal Building Systems Manual and AISC Specification for the Design, Fabrication and Erection of Structural Steel Buildings.

B. Building Parts

Accurate and true to dimension to facilitate building erection without cutting, fitting or other alterations.

C. Wall Panels:

- 1) One-piece top to bottom.
- 2) Side laps: Minimum one full corrugation sealed and fastened as follows:
 - a. Wall Panels: Self-tapping screws.
 - b. Roof Panels: Moveable slip folded into lock seam.
- 3) Panel Joints: Self-sealing.

D. Roof Panels:

- 1) Type: Standing lock seam.
- 2) Length: One-piece from eave to ridge except factory-punched penetrations at eave structural.
- 3) Thermal Spacer Blocks: Furnish over purlins.
- 4) Roof Ridge Panels: Same configuration as roof panels; one-piece factory-formed to fit roof slope and match roof; extend beyond first purlin from centerline of building.

- 5) End laps: 6 inches minimum.
- 6) Panel Design: Expansion and contraction capability for ambient temperature range of 120 degrees F without buckling, opening of joints or other detrimental effects.
- 7) Translucent Panels: Manufacturer's standard.
- 8) Ventilation Devices: Per manufacturers' recommendation for installation.

E. Frame Connections

Furnish panel-to-panel and panel-to-structural connections with self-tapping screws; maintain weather tight seal.

PART 3 EXECUTION

3.1 PREPARATION

Obtain manufacturer's written instructions before commencing erection or installation.

3.2 BUILDING ERECTION

- A. In accordance with manufacturer's standards and instructions.
- B. Structural Parts: No field cutting permitted.
- C. Roof and Wall Covering and Accessories:
 - 1) Field Cutting or Patching: Not permitted unless otherwise approved by JAXPORT Project Manager.
 - 2) Approved Field Modification: Perform in manner not to impair appearance, weather tightness or structural quality of material or structure.

3.3 ADJUSTING

- A. Replace or restore to original condition with project manager's approval:
 - 1) Surface finishes damaged prior to or during erection.
 - 2) Components where material and workmanship does not meet specified requirements.
- B. Minor Scratches, Dents and Holes

With Project Manager's approval, repair, and paint with similar finish coating of thickness and color to match original.

3.4 FIELD QUALITY CONTROL

A. Manufacturer's Services

Provide manufacturer's representative at site for installation assistance, inspection, and certification of installation.

ATTACHMENT “A”

How to Submit Your Bid Response in E-Builder



After reviewing the bid package invitation, use the Response Form tab to submit your bid response.

To submit your proposal:

1. [Access](#) the bid package.
2. Click the **Response Form** tab.
3. On the **Step 1: Bid Form** tab, enter your pricing on the bid form line items.

Ensure that you provide pricing at the level of detail required by the bid manager (if applicable). Some line items may be lump sum, and others may require quantities and unit prices.

- If there are areas that do not pertain to your trade, enter a zero (0) value in that line.
- The Summary box at the top of the page maintains a running total of your entries for reference.

4. Click  (Save). Ensure that your work is saved periodically.
5. *Optional:* To export the bid items to a spreadsheet that you can customize or that you can share with your team, click  (Download). After updating the spreadsheet, click  (Upload) to re-import it.
6. On the **STEP 2: Response Documents** tab, click **Attach Documents**, and upload any supporting document needed to support your bid.
7. On the **STEP 3: Additional Required Info** tab, complete any additional questions or qualification statements that have been established by the bid manager. If any addenda have been issued, you are required to acknowledge receipt of the addenda on this page before submitting your bid.
8. Review the entire Response Form and click **Submit**.
9. When prompted, enter your e-Builder portal password and click **Submit Bid**.

The date and time that you submitted your bid is stamped on your Response Form. You will also receive an email confirmation.

Additional Notes

- ***After the bid due date/time has passed, the Submit button will be disabled. It is critical that you complete the entire process prior to the cut-off time. The system will not permit you to submit your proposal or bid after the deadline regardless of where you are in the process. As stated, the Submit button is systematically disabled promptly at the deadline and JAXPORT is unable to see anything you have uploaded prior to the bid due date/time. No late submissions will be permitted or accepted. Please plan accordingly.***
- If the bid manager adds or changes a bid item, or publishes an addendum, your bid will be set back to a Draft status. You will receive an email notification and will be required to reconfirm your bid and resubmit.
- When you need to step away from entering the quote, click  (Save). It is recommended that you save every 15 minutes. This will ensure that your changes are saved.
- If there are areas that do not pertain to your trade, enter a zero (0) value in that line item.
- If you have your qualifications in Word® or another program, copy and paste them into the qualifications.
- It is required that you acknowledge all the addenda, even if they do not pertain to your trade.

ATTACHMENT “A”

- It is recommended that you submit your quote at least 60 minutes before the due time so that you can rectify any errors. To submit the proposal, you must complete all the fields and acknowledge the addenda items.