



INVITATION TO BID EQ-1751

**PURCHASE OF THIRTY-TWO (32) LOW DOUBLE BITT BOLLARDS
FOR THE
JACKSONVILLE PORT AUTHORITY**

**Deadline for questions no later than,
WEDNESDAY, DECEMBER 16, 2020 by 12:00 PM (EST)**

**Submit responses no later than,
MONDAY, DECEMBER 28, 2020 by 2:00 PM (EST)**

to the attention:

**Jacksonville Port Authority
Procurement Services
via
E-Builder Electronic Bid Submission**

ITB EQ-1751

**PURCHASE OF THIRTY-TWO (32) LOW DOUBLE BIT BOLLARDS
FOR THE
JACKSONVILLE PORT AUTHORITY**

TABLE OF CONTENTS

ITEM	PAGE NO(S)
GENERAL INFORMATION.....	GI-1
LEGAL NOTICE.....	LN-1
ARTICLE I - Instructions to Bidders.....	A1-1 TO A1-8
ARTICLE II - General Conditions.....	A2-1 TO A2-7
ARTICLE III - Bid Form.....	A3-1 TO A3-7
ARTICLE IV - Scope of Services.....	A4-1 TO A4-10
ATTACHMENT NO. 1 - E-Builder - How to Submit Your Bid Response.....	EBSG-1 TO EBSG-2
EXHIBIT A - Conflict of Interest Certificate.....	COI-1
EXHIBIT B - Sworn Statement of Public Entity Crimes.....	PEC-1 TO PEC-2
EXHIBIT C - E-Verify Acknowledgement.....	E-VERIFY

**REQUESTS FOR DISTRIBUTION SHEETS OR
ATTENDANCE SHEETS**

Copies of the Invitation to Bid (ITB) distribution records may be requested by contacting Procurement Services.

SUBMISSION OF BIDS

Bids submitted electronically in advance of the time set for opening will be held in the E-Builder Bidding Portal until **2:00 PM (EST)**. Bidders are fully responsible for submittal of Bid. Reliance upon the computer system's reaction time is at Bidder's risk. After the bid due date/time has passed, the submit button will be disabled. **Late Bids will not be received or considered.**

BID OPENING PROCEDURES

Depending on the type of project for which Bids are requested, the items read at the opening will vary. Sealed Bids are not public records subject to disclosure under the Florida Public Records Law until such time as the Jacksonville Port Authority provides notice of a decision or intended decision to award the contract or within thirty (30) days after opening, whichever is earlier (§119.07 (3) (m), Florida Statutes). All parts of Bid, including exhibits, are subject to the Public Records Law, and a Bidder may not exclude any portion of the Bid unless specifically exempted from disclosure by Florida Law. Exemption of financial statements applies only to required submittal for prequalification of bidders on public works projects.

INVITATION TO BID RESULTS OR AWARD OF CONTRACT

Bidders desiring a copy of the unofficial tabulation sheet, which will contain only the items considered necessary by JAXPORT, can obtain a copy 30-days after the Bid opening by submitting a written request to Procurement Services. Requested copies will be sent to the Bidder by email. Bidders wishing to view Bids submitted, subject to the above Public Records requirements, must arrange an appointment by contacting Public Records at (904) 357-3091 or public.records@jaxport.com. If copies are requested, an appropriate charge will be assessed, and all copies will be made solely at the convenience of JAXPORT. All Bidders will be notified of the intent to award the contract after action by the Jacksonville Port Authority Awards Committee.

INVITATION TO BID EQ-1751

PURCHASE OF THIRTY-TWO (32) LOW DOUBLE BITT BOLLARDS FOR THE JACKSONVILLE PORT AUTHORITY

Bids will be received by the Jacksonville Port Authority (JAXPORT) via E-Builder Electronic Bid Submission up to **2:00 PM (EST)**, on **MONDAY, DECEMBER 28, 2020**, at which time they will be opened publicly via “Go to Meeting” at <https://global.gotomeeting.com/join/884114677>, Access Code: **884-114-677**.

All Bids must be submitted in accordance with the Invitation to Bid Number **EQ-1751**, which may be obtained from our website:

<https://www.jaxport.com/procurement/>

Procurement Services
P.O. Box 3005
Jacksonville, Florida 32206
(904) 357-3017

ARTICLE I INSTRUCTIONS TO BIDDERS

1.01 GENERAL INFORMATION

The Jacksonville Port Authority (JAXPORT) is soliciting bids from “Qualified and Experienced Firms” to provide **PURCHASE OF THIRTY -TWO (32) LOW DOUBLE BITT BOLLARDS** for Talleyrand , Blount Island and Dames Point Cruise Terminals.

1.02 RECEIPT AND OPENING OF BIDS

JAXPORT will receive bids until **MONDAY, DECEMBER 28, 2020 at 2:00 PM (EST)** from companies licensed, qualified and interested in providing **PURCHASE OF THIRTY-TWO (32) LOW DOUBLE BITT BOLLARDS**, as per specifications listed on this Invitation to Bid (ITB). These bids will be publicly opened via “Go to Meeting” and can be accessed from your computer, tablet or smartphone at the stated time and date listed above.

Please join my meeting from your computer, tablet or smartphone.

<https://global.gotomeeting.com/join/884114677>

You can also dial in using your phone.
(For supported devices, tap a one-touch number below to join instantly.)

United States (Toll Free): 1 866 899 4679
- One-touch: <tel:+18668994679,,884114677#>

United States: +1 (571) 317-3116
- One-touch: <tel:+15713173116,,884114677#>

Access Code: **884-114-677**

New to GoToMeeting? Get the app now and be ready when your first meeting starts:

<https://global.gotomeeting.com/install/884114677>

1.03 DELIVERY OF BIDS

Bids and all required supplemental material listed in Article III (*items to be submitted with Bid Form*) must be electronically submitted in **PDF format only** through E-Builder. Bid documents submitted through Email or Fax will not be accepted or considered. **Until further notice, JAXPORT is *not* accepting any bid packages submitted by Mail or Hand-Deliveries due to the current COVID-19 situation.** Please visit the JAXPORT’s website at www.jaxport.com for more information and updates.

The PDF file name should read **“ITB EQ-1751 PURCHASE OF THIRTY-TWO (32) LOW DOUBLE BITT BOLLARDS.”** “How to Submit Your Bid Response in E-Builder” is provided as **“Attachment No. 1”**. Additional instructions on how to navigate in E-Builder , click the below link to access the **“Bidders Portal Instructional Training Video”**:

<https://resources.e-builder.net/bidding/e-builder-bidders-portal-instructional-training-video>

Bids must be submitted prior to 2:00 PM (EST), MONDAY, DECEMBER 28, 2020. The submit button in E-Builder will deactivate exactly at **2:00 PM EDT** and you will not be permitted to submit your bid regardless of where you are in the process. Please plan accordingly.

Bids received after the above stated time and date will not be considered. It is the sole responsibility of the Bidder to have its Bid submitted to JAXPORT as specified herein on or before the aforementioned date and time. For the purpose of the ITB, a bid is considered delivered when confirmation of delivery is provided by E-Builder. Bidders must ensure that its electronic submission in E-Builder can be assessed and viewed at the time of the bid opening. JAXPORT will consider any file that cannot be immediately accessed and viewed at the time of the bid opening (such as, encrypted files, password protected files, or incompatible files) to be blank or incomplete as context requires, and are therefore unacceptable. Bidders will not be permitted to unencrypt files, remove password protections, or resubmit documents after bid opening to make a file viewable if those documents are required with bid. All expenses for submitting bids to JAXPORT are to be borne by the Bidder and will not be borne, charged to or reimbursed by JAXPORT in any manner or under any circumstance.

1.04 CONTRACT DOCUMENTS

The Contract Documents give the description of the work to be done under this Contract. The required qualifications of bidders, other technical information, applicable special conditions, term of the Contract and payment terms are also contained in these documents. The date, time, and place of the receipt and opening of bids are listed in Article 1.02 above.

1.05 EXAMINATION OF CONTRACT DOCUMENTS

The Bidder is required to carefully examine the sites of the work and the Contract documents. It will be assumed that the Bidder has investigated and is fully informed of the conditions, the character, and quality of work to be performed, any materials and equipment to be furnished, and of the requirements of the Contract documents.

1.06 OBLIGATION OF BIDDERS

The Bidder must become fully aware of JAXPORT's requirements for the Contract. Failure to do so will not relieve a successful Bidder of its obligation to furnish the material, equipment and labor necessary to carry out the provisions of the Contract Documents and to complete the work at the prices proposed. In addition, the Bidder will be held responsible for having examined the details of the proposed scope of work. The Bidder will use its personal knowledge and experience or professional advice as to the character of the proposed work and any other conditions surrounding and affecting the proposed work. The submittal of a bid will be construed as evidence that all Bidder obligations have been satisfied and no subsequent allowance will be made in this regard.

1.07 QUESTIONS & ADDENDUM

Any questions regarding this Invitation to Bid (ITB) should be directed to **Sandra Platt, Sr. Contract Specialist** and submitted either by email to sandra.platt@jaxport.com or submittal through E-Builder. Answers to questions will be released in an Addendum directed to all known prospective bidders registered in the E-Builder's website and advertised on JAXPORT's website under Active Solicitations at <https://www.jaxport.com/procurement/active-solicitations>.

The deadline for questions will be WEDNESDAY, DECEMBER 16, 2020 at 12:00 PM (EST).

No interpretation of the meaning of the specifications or other Contract Documents, or corrections of any apparent ambiguity, inconsistency or error therein, will be made to any Bidder orally. Any request for such interpretations or corrections must be made in writing.

Any such request which is not received prior to the above deadline date for questions will not be considered. All such interpretations and supplemental instructions will be in the form of written Addendum to the Contract Documents, which if issued, will be e-mailed to all known prospective bidders. However, it is the responsibility of each Bidder, before submitting its bid, to contact Procurement Services at (904) 357-3017 to determine if any Addendum have been issued and to make such Addendum a part of its bid. Only the interpretation or correction so given by JAXPORT in writing will be binding, and prospective bidders are advised that only JAXPORT will give information concerning, or will explain or interpret the ITB Documents.

1.08 PREPARATION OF BID

- A. Bid will be submitted via E-Builder Electronic Bid Submission with the attached Bid Form (Article III). All blank spaces must be complete and all item fields acknowledged prior to submittal. Only the Bid Form and applicable additional information should be submitted. **DO NOT SUBMIT ANY OTHER PORTIONS OF THE ORIGINAL JAXPORT BID PACKAGE.**
- B. Bid should be prepared in **PDF format only** and uploaded simply and economically avoiding the use of elaborate promotional materials beyond those sufficient to provide a straightforward, concise description of the Bidder's capabilities to satisfy the requirements of this Invitation to Bid (ITB). Emphasis should be on completeness and clarity of content and ease of locating responses to requested information.
- C. Any information thought to be relevant, but not applicable to the enumerated scope of services, should be uploaded and "labeled" in PDF format as an Appendix to the bid. If publications are supplied by a Bidder, it must be uploaded as a PDF document and the bid should include reference to a document number and/or page number of that Appendix material. Bids not providing this reference will be considered to have no additional material to be considered during the evaluation process.
- D. An authorized representative shall sign the bid. If an individual makes the bid, he or she must sign his or her name therein and state his or her address and the name and address of every other person interested in the bid as principal. If a firm or partnership makes the bid, the name and address of each member of the firm or partnership must be stated. If a corporation makes the bid, an authorized officer must sign the bid or agent, subscribing the name of the corporation with his or her own names. Such officer or agent must also state the name of the State, under which the corporation is chartered, and the names and business address of the President, Secretary and Treasurer. If applicable, also provide evidence of registration with the Secretary of State of the State of Florida for doing business in the State of Florida.
- E. Bids will be uploaded in accordance with requirements specified on this Invitation to Bid.
- F. Failure to upload all information requested may result in a bid being considered "non-responsive," and therefore, may be rejected.

1.09 RESPONSIBLE BIDDER CRITERIA

In considering the responsibility of Bidders JAXPORT will examine all requirements listed and submitted with the ITB.

1.10 WITHDRAWAL OF BID

Any bid may be withdrawn by written request of the Bidder until the date and time set above for opening of the bids. Any bid not so withdrawn will, upon opening, constitute an irrevocable offer for one hundred eighty (180) days (or until one or more of the bids have been duly accepted by JAXPORT, whichever is earlier) to provide JAXPORT the services set forth in the attached specifications. JAXPORT's action on bids normally will be taken within sixty (60) days of opening; however, no guarantee or representation is made as to the time between the bid opening and the subsequent JAXPORT action.

1.11 DISQUALIFICATIONS OF BIDDERS

Any of the following causes may be considered sufficient for the disqualification of a Bidder and rejection of the bid:

- A. Submission of more than one bid for the same work by an individual, firm, partnership or corporation under the same or different names. If a company has more than one division, only one bid may be submitted for the company.
- B. Evidence of collusion among Bidders.

- C. Incomplete work for which the Bidder is committed by contract which, in the judgment of JAXPORT, might hinder or prevent the Bidder with complying with the requested scope of services under this Contract if awarded to such Bidder.
- D. Being in arrears on any existing agreement with JAXPORT or having defaulted on a previous contract with JAXPORT. For purposes of this section, corporations, partnerships or companies, or firms or other business entities created for the purpose of shielding any individual, firm, Partnership Corporation, or other business entity from the application of this provision may be considered for disqualification.
- E. Items 'C' and 'D' above will be considered by JAXPORT after the opening of bids, and, if found to apply to any Bidder, JAXPORT will notify the Bidder that its bid will not be considered for an award of the Contract. The Bidder has five (5) business days to appeal in writing this decision to JAXPORT Chief Executive Officer, via Procurement Services, and the decision of the Chief Executive Officer will be final.
- F. Failure to provide the notarized forms, if any, required in the bid documents, and any other requirements listed in Article III.
- G. Failure to disclose any disciplinary actions taken or pending against the firm within the past three (3) years.

Failure to provide requested information listed above may result in the Bidder being ruled non-responsive.

1.12 NON-WARRANTY OF ITB INFORMATION

Due care and diligence has been exercised in the preparation of this ITB and all information contained herein is believed to be substantially correct. However, the responsibility for determining the full extent of the exposures to risk and verification of all information herein shall rest solely with those making bids. JAXPORT and its representatives shall not be responsible for any error or omission in the ITB.

1.13 CONTINGENCY FEES PROHIBITED

By submitting a bid in response to this ITB, the Bidder warrants that it has not employed or retained a company or person, other than a bona fide employee or sub bidder, working in its employ, any fee, commission, percentage, gift or other consideration contingent upon or resulting from the award of making a contract with JAXPORT.

1.14 REJECTIONS OF IRREGULAR BIDS

Bids will be considered irregular and may be rejected if they show omissions, alterations of form, additions not called for, conditions, limitations, unauthorized alternate bids or other irregularities of any kind. JAXPORT reserves the right to waive any non-conformance or irregularities of bids, or to reject any or all bids, in whole or in part, whenever such non-conformance or irregularities are minor and such action is deemed to be in the best interest of JAXPORT.

In this regard, JAXPORT reserves the right to reject any and all bids, in whole or in part, and to waive any non-conformance or any other irregularities received in said bid, to reject any and all bids and to accept the bid which in its judgment will be in the best interest of JAXPORT.

1.15 PUBLIC ENTITY CRIME

Pursuant to Chapter 287 of the Florida Statutes, Bidders are required to complete and submit with their bids a Sworn Statement Pursuant to Section 287.133 (3) (a), Florida Statutes, on Public Entity Crimes. **Form PEC is provided as "Exhibit B"** for that purpose and must be included with the bid form at the time bids are submitted.

A person or affiliate placed on the convicted vendor list following a conviction for a public entity crime is prohibited from doing any of the following for a period of 36 months from the date of being placed on the convicted vendor list:

- Submitting a bid on a contract to provide any goods or services to a public entity;
- Submitting a bid on a contract with a public entity for the construction or repair of a public building or public work;
- Submitting bids on leases of real property to a public entity;

- Being awarded or performing work as a Bidder, supplier, sub Bidder, or Bidder under a contract with any public entity; and
- Transacting business with any public entity in excess of Category Two threshold amount (\$35,000) provided in section 287.017 of the Florida Statutes.

1.16 DISCRIMINATORY VENDOR LIST

An entity or affiliate placed on the discriminatory vendor list pursuant to section 287.134 of the Florida Statutes may not:

- Submit a bid on a contract to provide any goods or services to a public entity;
- Submit a bid on a contract with a public entity for the construction or repair of a public building or public work;
- Submit bids on leases of real property to a public entity;
- Be awarded or perform work as a contractor, supplier, subcontractor, or Contractor under a contract with any public entity; or
- Transact business with any public entity.
- To view a current list, visit:

http://www.dms.myflorida.com/business_operations/state_purchasing/vendor_information/convicted_suspended_discriminatory_complaints_vendor_lists

1.17 BIDDERS REPRESENTATION AND AUTHORIZATION

In submitting a bid, each Bidder understands, represents, and acknowledges the following (if the Bidder cannot certify to any of the following, the Bidder shall submit with its response a written explanation of why it cannot do so).

- The Bidder is not currently under suspension or debarment by the State or any other governmental authority.
- To the best of the knowledge of the person signing the bid documents, the Bidder, its affiliates, subsidiaries, directors, officers, and employees are not currently under investigation by any governmental authority and have not in the last ten (10) years been convicted or found liable for any act prohibited by law in any jurisdiction, involving conspiracy or collusion with respect to bidding on any public contract.
- Bidder currently has no delinquent obligations to the State, including a claim by the State for liquidated damages under any other contract.
- The bid submission is made in good faith and not pursuant to any agreement or discussion with, or inducement from, any firm or person to submit a complementary or other noncompetitive response.
- The prices and amounts have been arrived at independently and without consultation, communication, or agreement with any other respondent or potential respondent; neither the prices nor amounts, actual or approximate, have been disclosed to any Bidder or potential Bidder, nor they will not be disclosed before the solicitation bid opening.
- The Bidder has fully informed JAXPORT in writing of all convictions of the firm, its affiliates (as defined in section 287.133(1)(a) of the Florida Statutes), and all directors, officers, and employees of the firm and its affiliates for violation of state or federal antitrust laws with respect to a public contract for violation of any misrepresentation with respect to a public contract. This includes disclosure of the names of current employees who were convicted of contract crimes while in the employ of another company.
- The product(s) offered by the Bidder will conform to the specifications without exception.
- The Bidder has read and understands the Contract terms and conditions, and the submission is made in conformance with those terms and conditions.
- If an award is made to the Bidder, the Bidder agrees that it intends to be legally bound to the Contract that is

formed with the JAXPORT.

- The Bidder has made a diligent inquiry of its employees and agents responsible for preparing, approving, or submitting the response, and has been advised by each of them that he or she has not participated in any communication, consultation, discussion, agreement, collusion, act or other conduct inconsistent with any of the statements and representations made in the response.
- The Bidder shall indemnify, defend, and hold harmless JAXPORT and its employees against any cost, damage, or expense which may be incurred or be caused by any error in the respondent's preparation of its bid.
- All information provided by, and representations made by, the Bidder are material and important and will be relied upon by JAXPORT in awarding the Contract. Any misstatement shall be treated as fraudulent concealment from JAXPORT of the true facts relating to submission of the bid. A misrepresentation shall be punishable under law, including, but not limited to, Chapter 817 of the Florida Statutes.
- That the Bidder has carefully examined the Scope of Services and that from his/her investigations has been satisfied as to the nature and location of the work, the kind and extent of the services needed for the performance of the work, the general and local conditions, all difficulties to be encountered, and all other items which in any way affect the work or its performance.
- That the Bidder is in full compliance with all Federal, State, and local laws and regulations and intends to fully comply with same during the entire term of the contract.

1.18 E-VERIFY PROGRAM FOR EMPLOYMENT VERIFICATION

Bidders are required to complete and submit with their bids an E-Verify Acknowledgement and Acceptance Form. **Form is provided as "Exhibit C"**. The successful bidder agrees to utilize the U.S. Department of Homeland Security's E-Verify system to verify the employment eligibility of all new employees hired by the contractor during the term of this contract. Successful bidders must include in all subcontracts the requirement that subcontractors performing work or providing goods and services utilize the E-Verify system to verify the employment eligibility of all new employees hired by the subcontractor during the contract term. The successful bidder further agrees to maintain records of its participation and compliance and its subcontractor's participation and compliance with the provisions of the E-Verify program, and to make such records available to JAXPORT upon request. Failure to comply with this requirement will be considered a material breach of the contract.

1.19 NON-DISCRIMINATION PROVISIONS

The Bidder will have all state, county and local licenses and permits as may be required by law to perform the described services. The Bidder agrees to comply with all applicable Federal, State and local laws, including the Civil Rights Act 1964, as amended. The Equal Employment Opportunity Clause in Section 202 paragraph 1 through 7 of Executive Order 11246, as amended, relative to Equal Employment and the implementing Rules and Regulations of the Office of Federal Contract Compliance Programs are incorporated herein by specific reference. The Affirmative Action Clause in Section 503 of the Rehabilitation Act of 1973, as amended, relative to Equal Opportunity for the disabled is incorporated herein by specific reference.

The Affirmative Action Clause in 38 USC Section 2-12 of the Vietnam Veterans' Readjustment Assistance Act of 1974, relative to Equal Employment Opportunity for the special disabled veteran and veterans of the Vietnam Era, is incorporated herein by specific reference.

1.20 PUBLIC MEETING REQUIREMENTS

JAXPORT is required to comply with Section 286.011 of the Florida Statutes. Therefore, Evaluation Committee meetings and meetings of the Awards Committee are required to be held in public with sufficient notice made of the time and date of the meeting. All notices of public meetings are posted in the lobby of the Jacksonville Port Authority, 2831 Talleyrand Avenue, Jacksonville, FL 32206.

1.21 PUBLIC RECORDS

In accordance with Section 119.0701, Florida Statutes, the Contractor shall:

- (a) Keep and maintain public records required by the JPA to perform the services; and
- (b) Upon request from the JPA's custodian of public records, provide the JPA with a copy of the requested records or allow records to be inspected or copied within a reasonable time at a cost that does not exceed the cost provided for in Chapter 119, Florida Statutes, or as otherwise provided by law; and
- (c) Ensure that public records that are exempt or confidential and exempt from public records disclosure requirements are not disclosed except as authorized by law for the duration of the Contract term and following completion of this Contract if Contractor does not transfer the records to the JPA; and
- (d) Upon completion of this Contract, transfer to the JPA at no cost all public records in possession of Contractor or keep and maintain public records required by the JPA to perform the service. If Contractor transfers all public records to the JPA upon completion of this Contract, Contractor shall destroy any duplicate public records that are exempt or confidential and exempt from public records disclosure requirements. If Contractor keeps and maintains public records upon completion of this Contract, Contractor shall meet all applicable requirements for retaining public records. All records stored electronically must be provided to the JPA upon request from either JPA's custodian of public records in a format that is compatible with the JPA's information technology systems.

The above requirements apply to a "Contractor" as defined in Section, 119.0701, Florida Statutes.

IF CONTRACTOR HAS QUESTIONS REGARDING THE APPLICATION OF CHAPTER 119, FLORIDA STATUTES, TO THE CONTRACTOR'S DUTY TO PROVIDE PUBLIC RECORDS RELATING TO THIS CONTRACT, CONTACT THE JPA'S CUSTODIAN OF PUBLIC RECORDS AT (904) 357-3091 public.records@jaxport.com; JACKSONVILLE PORT AUTHORITY, PUBLIC RECORDS REQUEST, 2831 TALLEYRAND AVENUE, JACKSONVILLE, FLORIDA 32206.

1.22 PROTEST PROCEDURES

Respondents shall file any protest regarding this ITB in writing, in accordance with JAXPORT's Protest Procedures promulgated on SOP-1215 Procurement Code for the Jacksonville Port Authority, available at <https://www.jaxport.com/procurement>

1.23 EX-PARTE COMMUNICATION PROHIBITED

JAXPORT believes that any ex-parte communication concerning the solicitation, evaluation, and selection process denies all firms submitting bids fair, open, and impartial consideration. Adherence to procedures which ensure fairness is essential to the maintenance of public confidence in the value and soundness of the important process of public procurement of professional services. Therefore, during the solicitation, evaluation, and selection process, any ex-parte communication between a firm, its employees, agents, or representatives; and JAXPORT, its members, employees, agents, legal counsel, or representatives; other than JAXPORT's designated representative identified herein, is strictly prohibited. Failure to observe this requirement shall result in rejection of a firm's bid. For purposes of this section, the term "ex-parte communication" shall mean any oral or written communication relative to this solicitation, evaluation, and selection process, which occurs outside of an advertised public meeting, pursuant to Section 285.011, Florida Statutes.

This requirement shall not prohibit:

- A. Meetings called or requested by JAXPORT and attended by Bidders/Firms for the purpose of discussing this solicitation, evaluation, and selection process, including, but not limited to, substantive aspects of this ITB;
- B. The addressing of any elected or appointed governing authority of JAXPORT at public meetings advertised and conducted pursuant to, and in compliance with, Section 285.011, Florida Statutes;
- C. The filing and prosecution of a written protest to any proposed award to be made pursuant to this solicitation, evaluation, and selection process, which filing and prosecution shall give notice to all firms. Protest proceedings shall be limited to open public meetings with no ex-parte communication outside those meetings.

1.24 EXECUTION OF THE CONTRACT

Within twenty (20) days after Notice of Award, the successful Bidder will furnish the required certificates of insurance and any other requirements and enter into a formal agreement with JAXPORT. Failure to execute the Agreement as provided in these documents within twenty (20) days from the date of Notice of Award may be just cause, unless such failure has been caused by JAXPORT, for JAXPORT to annul and void the award. Award may then be made to another Bidder, or the contract may be re-advertised, as in the best interest of both entities. No award will be binding upon JAXPORT until the agreement has been executed by all appropriate parties.

1.25 ARTICLE/SECTION HEADINGS

Article or Section headings offering herein are inserted for convenience only, or reference only, and will in no way be construed to be interpretation of the text of this ITB.

1.26 ORDER OF PRECEDENCE

In the event of any conflict between the provisions of the Contract, the provisions of JAXPORT'S Invitation to Bid, referred and incorporated in the Contract, said provisions will be given preference in the following order: 1) Amendments to Contract; 2) Contract No. **EQ-1751**; 3) Addenda to Bid; 4) JAXPORT'S Invitation to Bid No. **EQ-1751**; and 5) Bidder's Bid.

1.27 VENUE

The venue of any legal action brought by or filed against JAXPORT relating to any matter arising under this ITB will be exclusively in the appropriate court, sitting in Duval County, Florida that has jurisdiction over such legal action. This ITB will be governed by and interpreted under the laws of the State of Florida.

1.28 ENTIRE AGREEMENT

This ITB is the entire agreement of the Parties and the Parties are not bound by any stipulations, representations, agreements, or promises, oral or otherwise, not printed or inserted in this ITB. Bidder agrees that no representations have been made by JAXPORT to induce the Bidder to enter into this ITB other than as expressly stated in this ITB. This ITB can neither be changed orally, nor by any means other than by written amendments expressly referencing this ITB and signed by all Parties hereto.

1.29 TAX EXEMPT

JAXPORT is exempt from State of Florida sales tax. The tax-exempt number is 85-8012544323C-8.

ARTICLE II GENERAL CONDITIONS

2.01 DEFINITIONS

JAXPORT - The Jacksonville Port Authority.

BIDDER - Any individual, firm or corporation submitting a bid for the work contemplated.

BID - The approved forms on which the Bidder is to submit, or has submitted, its charges for the work contemplated.

CONTRACT - The Contract consists of the document labeled "Specifications for **PURCHASE OF THIRTY-TWO (32) LOW DOUBLE BITT BOLLARDS** for the Jacksonville Port Authority", **ITB EQ-1751** and any Addendum issued before the execution of the Contract; Bidder's bid; and any Modification issued after execution of the Contract. A Modification is a written amendment to the Contract signed by both Parties. The order of precedence of contract documents will be as specified in Article 1.26.

CONTRACTING OFFICER - Designated JAXPORT individual who provides JAXPORT Inspector(s) with Contract information and monitors the administration of the Contract to ensure compliance with terms by both JAXPORT and the Bidder. The Contracting Officer is the only individual authorized to make Contract modifications. The Contracting Officer will be the Director of Procurement Services.

BIDDER - Any individual, firm or corporation entering into a Contract to perform the Scope of Work for JAXPORT.

BIDDER'S REPRESENTATIVE(S) - Individual(s) designated in writing by the Contractor at the time of Contract award as the only individual(s) authorized to act for the Contractor in all matters, including changes to Contract terms and to make estimates for repairs.

2.02 TECHNICAL SPECIFICATIONS

The work to be provided under this Contract is specified in Article IV, Scope of Work, with work to be provided as specified. JAXPORT, without invalidating the Contract, may order extra work or make changes by altering, adding to, or deducting from the work, and the Contract will be adjusted accordingly, based on a mutually agreed upon negotiated commission. Changes in the work and the contract fees may only be changed by prior written agreement executed by the parties with proper authorization to do so.

2.03 TERM OF CONTRACT

The term of the agreement for these services is intended to be for a **one-time purchase**. JAXPORT will award this contract to one Bidder who will be fully responsible for providing **THIRTY-TWO (32) LOW DOUBLE BITT BOLLARDS** to JAXPORT.

2.04 AWARD OF CONTRACT

JAXPORT intends to award a Contract to the Bidder offering the lowest price consistent with meeting all specifications, terms and conditions set forth on the ITB. No award will be made until all necessary inquiries have been made into the responsibility of the low bidder, and JAXPORT is satisfied that the low bidder is qualified to do the work and has the necessary organization, capital and equipment to provide these services under the terms of the contract.

JAXPORT reserves the right to accept or reject any or all bids, in whole or in part. There is no obligation by JAXPORT to award the ITB to the lowest bid offer, JAXPORT reserves the right to award the ITB to the Bidder submitting the bid that JAXPORT, in its sole discretion, determines will be most advantageous and beneficial. JAXPORT will be the sole judge of which bid will be in its best interest and its decision will be final.

Bids will be evaluated based on prices submitted on the Bid Form and on evaluation of the responsible mandatory and other requirements listed in Article IV. The Bidder must clearly and directly address each of these requirements. JAXPORT is not required to contact a Bidder to obtain additional information to evaluate the Bid.

2.05 ESCALATION / DE-ESCALATION – Not Applicable

2.06 CERTIFICATION/BIDDER QUALIFICATIONS

Bidder must be a qualified and licensed Firm and have current experience in providing the types of professional services required under this Invitation to Bid (ITB). The Bidder must become fully aware of the technical specifications, failure to do so will not relieve a successful Bidder of its obligation to provide JAXPORT'S requirements for the contract at the price submitted and in accordance with all specifications, terms, conditions and the delivery stated on this ITB.

2.07 PAYMENT

A. All invoices will reference the Contract No. **EQ-1751**. An original and one copy will be emailed to:

Accounts.payable@jaxport.com

or mailed to:

Jacksonville Port Authority
Attn: Accounts Payable
P.O. Box 3005
Jacksonville, FL 32206-3496

B. Invoices will be processed following normal JAXPORT payment procedures, which are **thirty (30) days net after receipt of an approved invoice**. Special or early payments will not be authorized.

2.08 RESPONSIBILITIES OF THE BIDDER

A. A post award conference will be scheduled after the Contract is awarded when the Bidder will furnish the certificates of insurance, copies of licenses and other items required by JAXPORT.

B. The Bidder will provide services as described in the Contract upon receipt of Notification of Award issued by JAXPORT.

C. The Bidder is responsible for product quality, timely delivery and responsiveness as listed in Article IV – Scope of Work.

D. The Bidder will remain liable for all damages to, or incurred by, JAXPORT caused by the Bidder's negligent performance of any of the services furnished under this Contract.

E. The Bidder represents that it is an independent Bidder and not an employee of JAXPORT, nor are any of Bidder's employees performing services in furtherance of this Contract to be considered employees of JAXPORT. The Bidder is responsible for any federal or state taxes applicable to this Contract and for complying with the requirements of all federal and state laws about income tax withholding, unemployment insurance and other insurance applicable and necessary for its employees. Employees of the Bidder will not be eligible for any Federal Social Security, State Worker's Compensation or unemployment insurance under this Contract except as employees of the Bidder.

F. The Bidder will designate in writing a qualified person(s) to act as its designated representative. The Bidder's Representatives(s) will have authority to act for the Bidder in all matters covered by this Contract.

- G The Bidder will notify JAXPORT Contact in writing, prior to affecting a personnel change concerning the professional personnel assigned to the Contract. JAXPORT will have the right to reject any personnel assigned to perform work under this Contract.
- H All personnel employed by the Bidder will be competent, trustworthy and properly trained. The Bidder and its employees will be required to comply with all the applicable regulations of JAXPORT.

2.09 RESPONSIBILITIES OF JAXPORT

- A. At the post award conference, JAXPORT will provide a list of personnel, with phone numbers, who are designated as JAXPORT representatives.
- B. JAXPORT will promptly notify the Bidder, or its designated representative(s), of any problem encountered during the Contract term and will arrange for a meeting to resolve issues.
- C. JAXPORT will provide timely processing of Bidder's invoices, if all the terms of the Contract have been met. In cases where Contract procedures were not followed, every attempt will be made to reach an agreement acceptable to both parties, but JAXPORT will not be liable for costs billed by the Bidder in violation of Contract terms.

2.10 INDEMNIFICATION

Any Contract resulting from this Invitation to Bid will include the following provisions:

To the fullest extent permitted by law, the Bidder agrees to indemnify, defend and hold harmless JAXPORT, its officers, agents, volunteers, and employees from and against all claims, damages, losses, and expenses, including but not limited to all fees and charges of engineer(s), architect(s), attorney(s) and other professional(s), court costs, or other alternative dispute resolution costs arising out of, resulting from, or otherwise but for the performance or furnishing of Bidder's work or services under this Invitation to Bid; provided that any such claim, damage, loss or expense is attributable to bodily injury, sickness, disease, death or personal injury, or property damage, including the loss of use or diminution in value resulting there from; but only to the extent caused in whole or in part by the actual or alleged negligent acts, errors, or omissions of Bidder, Bidder's Subcontractor(s) or anyone directly or indirectly employed or hired by Bidder, or anyone for whose acts Bidder may be liable. JAXPORT reserves the right, but not the obligation, to participate in defense without relieving Bidder of any obligation hereunder.

2.11 INSURANCE

Before starting and until acceptance of the work by JAXPORT, any contract resulting from this Invitation to Bid will include the following provisions:

- A. Without limiting its liability under the contract, the Bidder will obtain and maintain at its sole expense during the life of the contract, insurance of the types and in the minimum amount stated below:
- (1) Comprehensive General Liability- Premises-Operations, Products-Completed Operations, Contractual Liability, Independent Bidders, Insurance Limits: \$1,000,000 each occurrence, \$2,000,000 annual aggregate for bodily injury and property damage. JAXPORT will be included as an additional insured under the policy for both ongoing and completed operations using ISO form CG 20 10 10/1 addition date (for ongoing operations) and CG 20 37 10/1 addition date (for completed operations), or substitute endorsements providing equivalent coverage.
 - (2) All autos-owned, hired, or non-owned; Insurance Limits: \$300,000 each occurrence, combined single limit.
 - (3) Workers Compensation/Employers Liability at the minimum of the Florida Statutory coverage and Employer's Liability (including appropriate Federal Acts); Insurance Limits: Statutory Limits (Workers' Compensation) \$500,000 each accident (Employer's Liability).

- (4) Umbrella - (This is additional coverage and limits with the following “form coverage” for the following primary insurance: Employer's Liability, Commercial General Liability, and Automobile Liability); Insurance Limits: \$1,000,000 each occurrence and annual aggregate.
 - (5) DEDUCTIBLES AND SELF-INSURED RETENTIONS: Any deductibles or self-insured retentions must be declared to and approved by JAXPORT.
 - (6) ACCEPTABILITY OF INSURERS: Insurance is to be placed with insurers with a Best’s rating of no less than A: VI, and approved to do business in the State of Florida.
- B. The insurance specified above will, either by separate policy, provisions in the policies or by special endorsements attached thereto, insure JAXPORT against the risks to which it is exposed as the owner of the premises. The inclusion of JAXPORT as an additional insured is not intended to, and will not make JAXPORT a partner or joint venture with Bidder in Bidder's services at JAXPORT. Such policies will also insure Bidder against the risks to which it is exposed as the Bidder authorized under this ITB and will be for full coverage without any deductibles and/or retentions subject to approval by JAXPORT and will contain provisions by the respective insurers waiving the right of such insurers to subrogation.
- C. The proof of insurance supplied before execution of this contract will have the words "endeavor to” stricken.
- D. All insurance will be maintained in force until completion of the work, and will include an endorsement requiring thirty (30) days prior written notice to JAXPORT’s Risk Manager before any change or cancellation is made effective.
- E. Such insurance will be written by a company or companies licensed to do business in the State of Florida and satisfactory to JAXPORT. Before commencing any work under this contract, certificates evidencing the maintenance of said insurance will be furnished to JAXPORT and will be subject to the approval of JAXPORT’s Risk Manager, P.O. Box 3005, Jacksonville, FL 32206.
- F. Any sub Bidders of Company shall procure and maintain the insurance required of Company hereunder during the life of the subcontracts. Sub Bidders' insurance may be either by separate coverage or by endorsement under insurance provided by Company. Company shall submit sub Bidders' Certificates of Insurance to JAXPORT prior to allowing sub Bidders to perform Work on JAXPORT's job sites.

2.12 SECURITY IMPLEMENTATION PROCEDURE – Not Applicable

2.13 PERMITS AND LICENSES

All licenses necessary to carry out the delivery will be secured and paid for by the Bidder and remain in effect throughout the duration of the Contract.

2.14 PERFORMANCE BOND REQUIREMENT – Not Required

2.15 TERMINATION FOR DEFAULT

If through any cause within the reasonable control of the successful Bidder/Firm, it shall fail to fulfill in a timely manner, or otherwise violate any of the covenants, agreements, or stipulations material to the Agreement, JAXPORT shall thereupon have the right to terminate the services then remaining to be performed by giving written notice to the successful Bidder of such termination which shall become effective upon receipt by the successful Bidder of the written termination notice.

In that event, JAXPORT shall compensate the successful Bidder in accordance with the Agreement for all services performed by the Bidder prior to termination, net of any costs incurred by JAXPORT as a consequence of the default.

Notwithstanding the above, the successful Bidder shall not be relieved of liability to JAXPORT for damages sustained by JAXPORT by virtue of any breach of the Agreement by the Bidder, and JAXPORT may reasonably withhold payments to

the successful Bidder for the purposes of set off until such time as the exact amount of damages due to JAXPORT from the successful Bidder is determined.

2.16 TERMINATION FOR CONVENIENCE

JAXPORT may, for its convenience, terminate the services then remaining to be performed at any time without cause by giving written notice to successful Bidder of such termination, which shall become effective one hundred twenty (120) days following receipt by Bidder of such notice. In that event, all finished or unfinished documents and other materials shall be properly delivered to JAXPORT. If the Agreement is terminated by JAXPORT as provided in this section, JAXPORT shall compensate the successful Bidder in accordance with the Agreement for all services actually performed by the successful Bidder and reasonable direct costs of successful Bidder for assembling and delivering to JAXPORT all documents. No compensation shall be due to the successful Bidder for any profits that the successful Bidder expected to earn on the balance of the Agreement. Such payments shall be the total extent of JAXPORT's liability to the successful Bidder upon a termination as provided for in this section.

2.17 ASSIGNMENT

Due to the additional administrative burden placed on JAXPORT, the Bidder will not assign or otherwise transfer its rights under the Contract, without the express written consent of JAXPORT.

2.18 FORCE MAJEURE

- A. Performance of this ITB by both JAXPORT and the Bidder will be pursued with due diligence in all requirements hereof; however, neither JAXPORT nor the Bidder will be considered in default in the performance of its obligations under this ITB to the extent that such performance is prevented or delayed by causes not within the control of either Party and not foreseeable or, if foreseeable cannot be avoided by the exercise of reasonable care, including, but not limited to, acts of civil or military authority (including but not limited to courts or administrative agencies); acts of God; war; riot; insurrection; inability to secure approval, validation or sale of bonds; inability to obtain any required permits, licenses or zoning; blockades; embargoes; sabotage; epidemics; pandemics; endemics; fires; floods; strikes; lockouts; or collective bargaining. Upon any delay resulting from such cause the time for performance of each Party hereunder (including the payment of monies if such event prevents payment) will be extended for a period necessary to overcome the effect of such delays.
- B. In case of any delay or nonperformance caused by the above causes, the Party effected will promptly notify the other in writing of the nature, cause, date of commencement and the anticipated extent of such delay, and will indicate the extent, if any, to which it is anticipated that any delivery or completion dates will be affected by that.

2.19 NON-WAIVER

Failure by either Party to insist upon strict performance of any of the provisions of this ITB will not release either Party of any of its obligations under the ITB.

**ARTICLE III
BID FORM**

BIDDER'S NAME: _____

BEFORE COMPLETING THIS FORM, ALL PROPOSERS SHOULD READ THE FOLLOWING INSTRUCTIONS CAREFULLY AND BE SURE THEY PREPARE THEIR PROPOSALS ACCORDINGLY. FAILURE TO COMPLY WITH THESE INSTRUCTIONS MAY RESULT IN REJECTION OF THE PROPOSAL OR MAY RESULT IN ANOTHER COMPANY BEING AWARDED THE CONTRACT.

Submit prices for the purchase of low double bitt bollards including all cost associated with delivery, freight, surcharge and any other related charges. All prices to be FOB Talleyrand Marine Terminal, 2064 East 11th Street, Jacksonville, FL 32206. JAXPORT will not pay any transportation insurance and or import charges.

Specifications: Low double bitt with lip, cast steel, primer coated, Schoellhorn-Albrecht Part ID S1428 or equal. Bidder is responsible for demonstrating that product is equal to the SA bollard.

PURCHASE OF THIRTY-TWO (32) LOW DOUBLE BITT BOLLARDS					
Item	Description	Estimate Quantity	UOM	Unit Cost	Total Cost
1.	Low Double Bitt Bollard with Lip, Cast Steel / Primer Coated	32	EA	\$	\$

Manufacturer's Warranty: _____

Lead Time in Weeks: _____ **Weeks**

Failure to provide above information in stated format may result in rejection of Bid.

BIDDER'S CERTIFICATION

1) Certification and Representations of the Bidder

By signing and submitting a Bid, the Bidder certifies and represents as follows:

- A. That it has carefully examined all available records and conditions, including sites if applicable, and the requirements and specifications of these Contract Documents prior to submitting its Bid. Where the Bidder visits sites, no work or other disturbance is to be performed while at the site without written permission by JAXPORT in advance of the site visit.
- B. That every aspect of its submitted Bid, including the Contract Price, are based on its own knowledge and judgment of the conditions and hazards involved, and not upon any representation of JAXPORT. JAXPORT assumes no responsibility for any understanding or representation made by any of its representatives during or prior to execution of the Contract unless such understandings or representations are expressly stated in the Contract and the Contract expressly provides that JAXPORT assumes the responsibility.
- C. That the individual signing the Bid is a duly authorized agent or officer of the firm. Bids submitted by a corporation must be executed in the corporate name by the President or Vice President. If an individual other than the President or Vice President signs the Bid, satisfactory evidence of authority to sign must be submitted with the Bid. If the Bid is submitted by a partnership, the Bid must be signed by a partner whose title must appear under the signature. If an individual other than a partner signs the Bid, satisfactory evidence of authority to sign must be submitted with the Bid. The corporation or partnership must be in active status at the Florida Division of Corporations at the time of submission of the Bid.
- D. That the firm maintains in active status any and all licenses, permits, certifications, insurance, bonds and other credentials including not limited to Contractor's license and occupational licenses necessary to perform the services. The Bidder also certifies that, upon the prospect of any change in the status of applicable licenses, permits, certifications, insurances, bonds or other credentials, the Bidder shall immediately notify JAXPORT of status change.
- E. That it read understands and will comply with Article 1.15, Public Entity Crime "Exhibit B" and Conflict of Interest Certificate "Exhibit A" of these instructions to Bidders.

THE REMAINDER OF THIS PAGE IS INTENTIONALLY LEFT BLANK

**INVITATION TO BID EQ-1751
PURCHASE OF THIRTY-TWO (32) LOW DOUBLE BITT BOLLARDS**

BIDDER'S ACKNOWLEDGMENT

I hereby acknowledge, as Bidder's authorized agent, that I have fully read and understand all terms and conditions as set forth in this Invitation to Bid (ITB), I have met the minimum requirements (**See Article I, Paragraph 1.09**), and will fully comply with such terms and conditions.

Date: _____

Company Name: _____

Bidder is a (*check one*): _____ Corporation _____ Partnership _____ Individual

Authorized Agent's Name: _____

Authorized Agent's Signature: _____

Authorized Agent's Title: _____

Authorized Agent's Email Address: _____

Telephone Number: _____ Fax Number: _____

Federal Identification Number : _____

Remittance Address: _____

City: _____ State: _____ Zip Code: _____

The following items must be submitted with the Bid Form:

- (1) Bid Form Article III - (Pages A3-1 thru A3-4);
- (2) Acknowledgement of Addenda, *if any*
- (3) Conflict of Interest Certificate (Exhibit "A")
- (4) Sworn Statement of Public Entity Crimes (Exhibit "B")
- (5) E-Verify Compliance Form (Exhibit "C")
- (6) Warranty, include copies of all details

Failure to provide above information in stated format may be grounds for rejection of Bid.

**INVITATION TO BID EQ-1751
PURCHASE OF THIRTY-TWO (32) LOW DOUBLE BITT BOLLARDS
FOR THE JACKSONVILLE PORT AUTHORITY**

NO BID FORM

If your firm cannot submit a Bid at this time, please provide the information requested in the space provided below and return it to:

**Jacksonville Port Authority
Attn: Procurement Services
2831 Talleyrand Avenue
Jacksonville, FL 32206**

We are unable to submit a Bid at this time due to the following reasons:

Name of Firm: _____

Signature: _____

Printed Name: _____

Title: _____

Telephone Number: _____ Email: _____

Address: _____

City: _____ State: _____ Zip Code: _____

**ARTICLE IV
SCOPE OF SERVICES**

4.01 SCOPE OF SERVICES

The Jacksonville Port Authority (JAXPORT) is seeking a qualified company to provide Thirty-Two (32) Low Double Bitt Bollards as per specifications listed in this Invitation to Bid (ITB). Therefore, the purpose of this solicitation is to request information about your company's abilities to provide products specified and to obtain pricing commitments for Low Double Bitt Bollards listed

4.02 REQUIRED PRODUCTS

Quantity Required: Thirty-Two (32)

Type: Low Double Bitt with Lip, Cast Steel, Primer Coated, Schoellhorn-Albrecht Part ID S1428 **OR EQUAL**. Bidder is responsible for demonstrating that its product is equal to the Schoellhorn-Albrecht bollard and supplying a schematic of the quoted bollard along with all dimensions (**ref. 4.07**).

Safe Working Load (SWL) per Bitt: 50 Tons (100 tons total SWL per bollard)

Bolt Pattern: Bollards must match the existing bolt pattern as the existing anchor bolts will be reused. Existing anchor bolt diameter is 1-1/2 inches.

Anchor Bolts and Hardware: Not Required.

Warranty: Manufacturer's standard warranty (**ref. 4.08**).

Delivery: NLT eighteen (18) weeks after Bidder acceptance of purchase order.

4.03 EQUAL OR SUBSTITUTION(S)

Industry or Manufacturer's equal will be accepted.

4.04 QUANTITIES TO BE PURCHASED

While JAXPORT fully intends to purchase thirty-two (32) low double bitt bollards from one (1) vendor on a "one-time" basis, JAXPORT reserves the right to purchase more or less than the quantities estimated on this ITB over the course of the contract, without incurring any increases in cost or penalties.

4.05 DELIVERY REQUIREMENTS

Bollards must be delivered no later than eighteen (18) weeks after receipt of purchase order.

The vendor will state Lead-Time on Bid Form. Lead-Time will be considered a factor for award of this contract.

All deliveries must be made via Flatbed Truck or Stake body. JAXPORT does not have loading dock facilities. Any deviation from specifications noted at time of delivery will constitute refusal of delivery and possible cancellation of order.

4.06 PICK UP AND RETURNS

JAXPORT reserves the right to return an order, in whole or in part, if the Bitt Bollards does not meet the required specifications or delivery date specified on this ITB. JAXPORT will be the sole judge as to acceptable quality; the vendor will coordinate all returns of materials at no charge to JAXPORT.

4.07 COMPLIANCE WITH SPECIFICATIONS

JAXPORT will accept bids equal to “Schoellhorn-Albrecht Part ID S1428” from other manufacturers. On all such quotes the bidder will clearly indicate the brand name and other pertinent information of product. Sufficient data in detail must be provided by the bidder to enable an intelligent comparison to be made with the particular brand or manufacturer specified. All information will be submitted in accordance with procedures stated on this ITB. Catalog cuts and technical descriptive data will be attached to the original copy of the ITB where applicable. Failure to submit the above information will be sufficient grounds for rejection of the bid. Any deviation from the specifications as written not previously submitted, required by the above, will be grounds for rejection of the bid.

4.08 WARRANTY

Vendor will specify the warranty period and the method to be used for return and replacement. JAXPORT will incur no cost to obtain replacements during original warranty period. This quote and subsequent contract are subject to the provision of the Uniform Commercial Code as it relates to warranties. The low double bitt bollards provided under this contract will have an express warranty of fitness for purpose.

4.09 ATTACHMENT

1. Schoellhorn-Albrecht Cut Sheet for Part ID S1428 (Rev 1 – 1/4)

This cut sheet is provided for **information only**. It shall not be construed from its inclusion in this Scope document that the only acceptable product would be the SA dock bollard. **Other manufacturer’s equal products are acceptable.**

How to Submit Your Bid Response in E-Builder



After reviewing the bid package invitation, use the Response Form tab to submit your bid response.

To submit your bid

1. [Access](#) the bid package.
2. Click the **Response Form** tab.
3. On the **Step 1: Bid Form** tab, enter your pricing on the bid form line items.

Ensure that you provide pricing at the level of detail required by the bid manager. Some line items may be lump sum, and others may require quantities and unit prices.

- If there are areas that do not pertain to your trade, enter a zero (0) value in that line.
- The Summary box at the top of the page maintains a running total of your entries for reference.

4. Click  (Save). Ensure that your work is saved periodically.
5. *Optional:* To export the bid items to a spreadsheet that you can customize or that you can share with your team, click  (Download). After updating the spreadsheet, click  (Upload) to re-import it.
6. On the **STEP 2: Response Documents** tab, click **Attach Documents**, and upload any supporting document needed to support your bid.
7. On the **STEP 3: Additional Required Info** tab, complete any additional questions or qualification statements that have been established by the bid manager. If any addenda have been issued, you are required to acknowledge receipt of the addenda on this page before submitting your bid.
8. Review the entire Response Form and click **Submit**.
9. When prompted, enter your e-Builder portal password and click **Submit Bid**.

The date and time that you submitted your bid is stamped on your Response Form. You will also receive an email confirmation.

It is recommended that you **submit your bid quote at least 15 minutes before the due time** so that you can rectify any errors. If you find it necessary to correct an error “prior” to the due date/time, the instructions as to how to recall and resubmit your bid quote is listed on the next page.

IMPORTANT NOTE:

The submit button in E-Builder will deactivate exactly at the appointed bid due date/time (*i.e.*, 2:00:00 PM EDT) and you will not be permitted to submit your bid regardless of where you are in the process. Please plan accordingly.

Recall your Bid Response *(only if necessary)*

If you failed to submit all documents or see an error on a page **after submitting** your bid, you can make changes to your bid before the due date/time without any interaction from the bid manager. The bid manager has no record of your bid response until you click Submit again.

To recall your bid response

1. On the **Response Form** tab, click **Recall Bid**.
2. Optionally provide a reason for your recall and then click **Yes, I am sure**.
Your previous submission information is displayed on the Response Form tab.
3. Click **Submit** to resubmit your bid prior to the bid due date/time.

Additional Notes

- After the bid due date/time has passed, the Submit button will be disabled. In some circumstances, the bid manager may allow late submissions and the button will continue to be enabled.
- If the bid manager adds or changes a bid item, or publishes an addendum, your bid will be set back to a Draft status. You will receive an email notification and will be required to reconfirm your bid and resubmit.
- When you need to step away from entering the quote, click  (Save). It is recommended that you save every 15 minutes. This will ensure that your changes are saved.
- If there are areas that do not pertain to your trade, enter a zero (0) value in that line item.
- If you have your qualifications in Word® or another program, copy and paste them into the qualifications.
- It is required that you acknowledge all the addenda, even if they do not pertain to your trade.
- To submit the quote, you must complete all the fields and acknowledge the addenda items.

EXHIBIT A

CONFLICT OF INTEREST CERTIFICATE

Bidder must execute either Section I or Section II hereunder relative to Florida Statute 112.313(12). Failure to execute either section may result in rejection of this bid/proposal.

SECTION I

I hereby certify that no official or employee of JAXPORT requiring the goods or services described in these specifications has a material financial interest in this company.

_____ Signature	_____ Company Name
_____ Name of Official (type or print)	_____ Business Address
	_____ City, State, Zip Code

SECTION II

I hereby certify that the following named JAXPORT official(s) and/or employee(s) having material financial interest(s) (in excess of 5%) in this company have filed Conflict of Interest Statements with the JAXPORT Office of the Executive Director, 2831 Talleyrand Ave., Jacksonville, Florida 32206, prior to the time of bid opening.

Name	Title or Position	Date of Filing
_____	_____	_____

_____ Signature	_____ Company Name
_____ Print Name of Certifying Official	_____ Business Address
	_____ City, State, Zip Code

PUBLIC OFFICIAL DISCLOSURE

JAXPORT requires that a public official who has a financial interest in a bid or contract make a disclosure at the time that the bid or contract is submitted or at the time that the public official acquires a financial interest in the bid or contract. Please provide disclosure, if applicable, with bid.

Public Official _____

Position Held _____

Position/Relationship with Bidder _____

EXHIBIT B

SWORN STATEMENT PURSUANT TO SECTION 287.133(3)(A), FLORIDA STATUTES, ON PUBLIC ENTITY CRIMES

THIS FORM MUST BE SIGNED AND SWORN TO IN THE PRESENCE OF A NOTARY PUBLIC OR OTHER OFFICIAL AUTHORIZED TO ADMINISTER OATHS.

1. This sworn statement is submitted to _____
(print name of the public entity)

by _____
(print individual's name and title)

for _____
(print name of entity submitting sworn statement)

whose business address is _____

and (if applicable) its Federal Employer Identification Number (FEIN) is _____

(If the entity has no FEIN, include the Social Security Number of the individual signing this sworn statement: _____.)

2. I understand that a “public entity crime” as defined in Paragraph 287.133(1)(g), **Florida Statutes**, means a violation of any state or federal law by a person with respect to and directly related to the transaction of business with any public entity or with an agency or political subdivision of any other state or of the United States, including, but not limited to, any bid or contract for goods or services to be provided to any public entity or an agency or political subdivision of any other state or of the United States and involving antitrust, fraud, theft, bribery, collusion, racketeering, conspiracy, or material misrepresentation.

3. I understand that “convicted” or “conviction” as defined in Paragraph 287.133(1)(b), **Florida Statutes**, means a finding of guilt or a conviction of a public entity crime, with or without an adjudication of guilt, in any federal or state trial court of record relating to charges brought by indictment or information after July 1, 1989, as a result of a jury verdict, nonjury trial, or entry of a plea of guilty or nolo contendere.

4. I understand that an “affiliate” as defined in Paragraph 287.133(1)(a), **Florida Statutes**, means:

1. A predecessor or successor of a person convicted of a public entity crime; or
2. An entity under the control of any natural person who is active in the management of the entity and who has been convicted of a public entity crime. The term “affiliate” includes those officers, directors, executives, partners, shareholders, employees, members, and agents who are active in the interest in another person, or a pooling of equipment or income among persons when not for fair market value under an arm’s length agreement, shall be a prima facie case that one person controls another person. A person who knowingly enters into a joint venture with a person who has been convicted of a public entity crime in Florida during the preceding 36 months shall be considered an affiliate.

5. I understand that a “person” as defined in Paragraph 287.133(1)(e), **Florida Statutes**, means any natural person or entity organized under the laws of any state or of the United States with the legal power to enter into a binding contract and which bids or applies to bid on contracts for the provision of goods or services let by a public entity, or which otherwise transacts or applies to transact business with a public entity. The term “person” includes those officers, directors, executives, partners, shareholders, employees, members, and agents who are active in management of an entity.

6. Based on information and belief, the statement which I have marked below is true in relation to the entity submitting this sworn statement. **(Indicate which statement applies.)**

_____ Neither the entity submitting this sworn statement, nor any of its officers, directors, executives, partners, shareholders, employees, members, or agents who are active in the management of the entity, nor any affiliate of the entity has been charged with and convicted of a public entity crime subsequent of July 1, 1989.

_____ The entity submitting this sworn statement, or one or more of its officers, directors, executives, partners, shareholders, employees, members, or agents who are active in the management of the entity, or an affiliate of the entity has been charged with and convicted of a public entity crime subsequent to July 1, 1989.

_____ The entity submitting this sworn statement, or one or more of its officers, directors, executives, partners, shareholders, employees, members, or agents who are active in the management of the entity, or an affiliate of the entity has been charged with and convicted of a public entity crime subsequent to July 1, 1989. However, there has been a subsequent proceeding before a Hearing Officer of the State of Florida, Division of Administrative Hearings and the Final Order entered by the Hearing Officer determined that it was not in the public interest to place the entity submitting this sworn statement on the convicted vendor list. **(Attach a copy of the final order)**

I UNDERSTAND THAT THE SUBMISSION OF THIS FORM TO THE CONTRACTING OFFICER FOR THE PUBLIC ENTITY IDENTIFIED IN PARAGRAPH 1 (ONE) ABOVE IS FOR THAT PUBLIC ENTITY ONLY AND, THAT THIS FORM IS VALID THROUGH DECEMBER 31 OF THE CALENDAR YEAR IN WHICH IT IS FILED. I ALSO UNDERSTAND THAT I AM REQUIRED TO INFORM THE PUBLIC ENTITY PRIOR TO ENTERING INTO A CONTRACT IN EXCESS OF THE THRESHOLD AMOUNT PROVIDED IN SECTION 287.017, FLORIDA STATUTES FOR CATEGORY TWO OF ANY CHANGE IN THE INFORMATION CONTAINED IN THIS FORM.

(signature)

(date)

STATE OF _____

COUNTY OF _____

PERSONALLY APPEARED BEFORE ME, the undersigned authority,

_____ who, after first being sworn by me, affixed
(name of individual signing)

his/her signature in the space provided above on this _____ day of _____, 20_____.

NOTARY PUBLIC

My commission expires:

EXHIBIT C

ACKNOWLEDGEMENT AND ACCEPTANCE OF E-VERIFY COMPLIANCE

E-VERIFY PROGRAM FOR EMPLOYMENT VERIFICATION

In accordance with the Governor of Florida, Executive Order Number 11-02 (Verification of Employment Status), whereas, Federal law requires employers to employ only individuals eligible to work in the United States; and whereas, the Department of Homeland Security's E-Verify system allows employers to quickly verify in an efficient and cost effective manner;

The Contractor agrees to utilize the U.S. Department of Homeland Security's E-Verify system to verify the employment eligibility of all new employees hired by the Contractor during the term of the contract. Contractors must include in all subcontracts the requirement that all subcontractors performing work or providing goods and services utilize the E-Verify system to verify the employment eligibility of all new employees hired by the subcontractor during the contract term. The Contractor further agrees to maintain records of its participation and compliance and its subcontractor's participation and compliance with the provisions of the E-Verify program, and to make such records available to JAXPORT upon request. Failure to comply with this requirement will be considered a material breach of the contract.

By signing below, I acknowledge that I have reviewed, accept and will comply with the regulations pertaining to the E-Verify program.

Company Name

Name of Official (*Please Print*)

Signature of Principal

Title

Date

Bollards

Low Double Bitt With Lip

- Anchor Bolts and Hardware Available
- Custom Coatings and Materials Available
- Optional Grout Holes

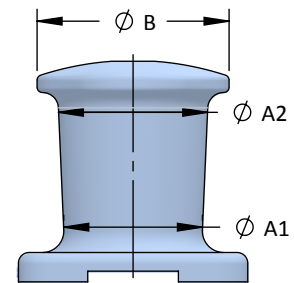
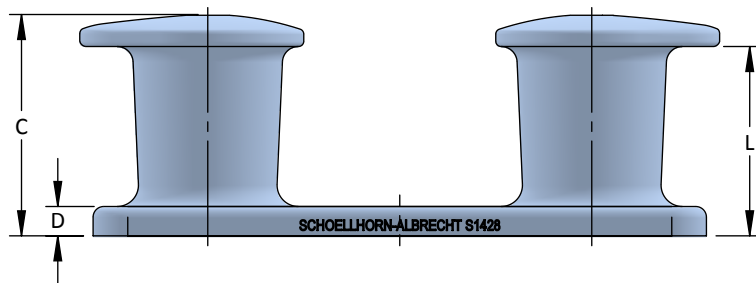
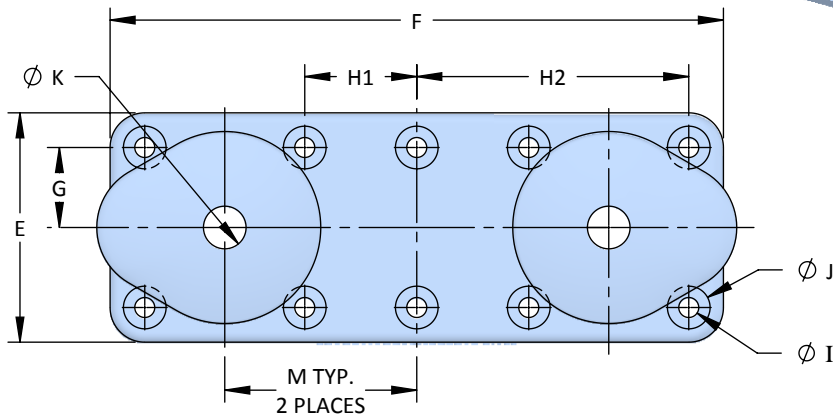
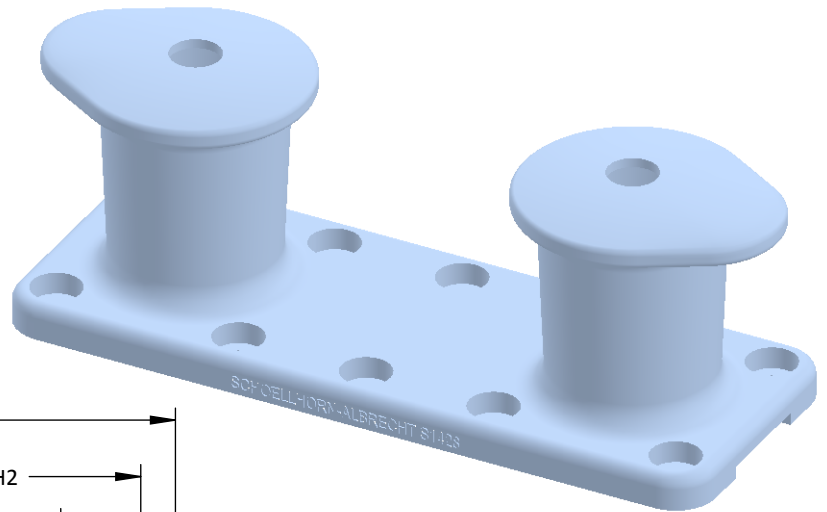

Model No.	Safe Working Load per Bitt (Tons)	A1	A2	B	C	D	E	F	G	H1	H2	I	J	K	L	M	No. of Bolts
S1428	50	13	14	18	20 ³ / ₄	2 ³ / ₄	21 ¹ / ₂	57 ¹ / ₂	7 ¹ / ₂	10 ¹ / ₂	25 ¹ / ₂	1 ⁷ / ₈	4	4	17 ³ / ₄	18	10

All dimensions are in inches and are subject to change.

